

CERAMICHE PIEMME

FLOOR AND MORE

Catalogo Generale | 2024

CLICK



INDEX

2 **A/Z**

Indice alfabetico / Alphabetical index /
Alphabetisches Verzeichnis /
Index alphabétique

3 **LOOKS**

Indice per effetto / Index by look /
Verzeichnis nach optik /
Index par effet

4 **SIZES**

Indice per formati/ Index of sizes /
Inhaltsübersicht formate /
Index des formats

6 **HISTORY**

8 **ABOUT US, MADE IN ITALY**

10 **SUSTAINABILITY**

12 **INNOVATION**

14 **SYNCHRO DIGIT PIEMME® TECHNOLOGY**

16 **MAKRO SLABS PROJECT**

18 FLOOR AND MORE Collection

20 STONE EFFECT

140 CEMENT EFFECT

182 MARBLE EFFECT

242 WOOD EFFECT

282 CONTEMPORARY

328 CONTRACT Collection

356 TECHNICAL DATA



CLICK

A/Z

18 Floor and More Collections

- 94 [Bits&Pieces](#)
- 124 [Castlestone](#)
- 272 [Cottage](#)
- 236 [Elegance](#)
- 64 [Evoluta](#) PREMIUM
- 256 [Fleur de Bois](#)
- 324 [Fragments](#)
- 104 [Geostone](#)
- 142 [Glitch](#)
- 284 [Homey](#) PREMIUM
- 52 [Ibla](#) PREMIUM
- 40 [Journey](#) PREMIUM
- 22 [Limestone](#) PREMIUM
- 210 [Majestic](#) PREMIUM
- 184 [Majestic Onyx](#) PREMIUM
- 198 [Majestic Pure Selection](#) PREMIUM
- 306 [Materia](#)
- 132 [More](#)
- 230 [Opulence](#) PREMIUM
- 114 [Purestone](#)
- 162 [Shades](#)
- 244 [Solorovere](#)
- 266 [Soul](#)
- 78 [Uniquestone](#)
- 174 [Urban](#)

328 Contract Collections

- 330 [Artdesia 2.0](#)
- 344 [Concrete](#)
- 334 [Opus](#)
- 340 [Suprema](#)
- 352 [Venetian Marble](#)

356 [Dati Tecnici](#)

Technical Data / Technische Daten / Fiches Techniques

CLICK

LOOKS

STONE EFFECT

- 22 [Limestone](#) PREMIUM
- 40 [Journey](#) PREMIUM
- 52 [Ibla](#) PREMIUM
- 64 [Evoluta](#) PREMIUM
- 78 [Uniquestone](#) FLOOR AND MORE
- 94 [Bits&Pieces](#) FLOOR AND MORE
- 104 [Geostone](#) FLOOR AND MORE
- 114 [Purestone](#) FLOOR AND MORE
- 124 [Castlestone](#) FLOOR AND MORE
- 132 [More](#) FLOOR AND MORE
- 330 [Artdesia 2.0](#) CONTRACT

CEMENT EFFECT

- 142 [Glitch](#) FLOOR AND MORE
- 162 [Shades](#) FLOOR AND MORE
- 174 [Urban](#) FLOOR AND MORE
- 334 [Opus](#) CONTRACT
- 340 [Suprema](#) CONTRACT
- 344 [Concrete](#) CONTRACT

WOOD EFFECT

- 244 [Solorovere](#) FLOOR AND MORE
- 256 [Fleur De Bois](#) FLOOR AND MORE
- 266 [Soul](#) FLOOR AND MORE
- 272 [Cottage](#) FLOOR AND MORE

MARBLE EFFECT

- 184 [Majestic Onyx](#) PREMIUM
- 198 [Majestic Pure Selection](#) PREMIUM
- 210 [Majestic](#) PREMIUM
- 230 [Opulence](#) PREMIUM
- 236 [Elegance](#) FLOOR AND MORE

CONTEMPORARY

- 284 [Homey](#) PREMIUM
- 306 [Materia](#) FLOOR AND MORE
- 324 [Fragments](#) FLOOR AND MORE
- 352 [Venetian Marble](#) CONTRACT

CLICK

SIZES

120x280

- 22** [Limestone](#) PREMIUM
- 210** [Majestic](#) PREMIUM
- 184** [Majestic Onyx](#) PREMIUM
- 198** [Majestic Pure Selection](#) PREMIUM
- 230** [Opulence](#) PREMIUM

120x120

- 94** [Bits&Pieces](#) FLOOR AND MORE
- 344** [Concrete](#) CONTRACT
- 142** [Glitch](#) FLOOR AND MORE
- 284** [Homey](#) PREMIUM
- 40** [Journey](#) PREMIUM
- 22** [Limestone](#) PREMIUM
- 210** [Majestic](#) PREMIUM
- 184** [Majestic Onyx](#) PREMIUM
- 198** [Majestic Pure Selection](#) PREMIUM
- 306** [Materia](#) FLOOR AND MORE
- 334** [Opus](#) CONTRACT
- 78** [Uniquestone](#) FLOOR AND MORE

90x90

- 306** [Materia](#) FLOOR AND MORE

80x80

- 344** [Concrete](#) CONTRACT
- 236** [Elegance](#) FLOOR AND MORE
- 104** [Geostone](#) FLOOR AND MORE
- 142** [Glitch](#) FLOOR AND MORE
- 210** [Majestic](#) PREMIUM
- 198** [Majestic Pure Selection](#) PREMIUM
- 334** [Opus](#) CONTRACT
- 162** [Shades](#) FLOOR AND MORE
- 340** [Suprema](#) CONTRACT
- 78** [Uniquestone](#) FLOOR AND MORE

60x120

- 330** [Artdesia 2.0](#) CONTRACT
- 344** [Concrete](#) CONTRACT
- 236** [Elegance](#) FLOOR AND MORE
- 64** [Evoluta](#) PREMIUM
- 256** [Fleur de Bois](#) FLOOR AND MORE
- 104** [Geostone](#) FLOOR AND MORE
- 142** [Glitch](#) FLOOR AND MORE
- 284** [Homey](#) PREMIUM
- 52** [Ibla](#) PREMIUM
- 40** [Journey](#) PREMIUM
- 210** [Majestic](#) PREMIUM
- 198** [Majestic Pure Selection](#) PREMIUM
- 306** [Materia](#) FLOOR AND MORE
- 230** [Opulence](#) PREMIUM
- 162** [Shades](#) FLOOR AND MORE
- 78** [Uniquestone](#) FLOOR AND MORE
- 352** [Venetian Marble](#) CONTRACT

45x90

- 124** [Castlestone](#) FLOOR AND MORE
- 104** [Geostone](#) FLOOR AND MORE

60x60

- 330** [Artdesia 2.0](#) CONTRACT
- 94** [Bits&Pieces](#) FLOOR AND MORE
- 124** [Castlestone](#) FLOOR AND MORE
- 344** [Concrete](#) CONTRACT
- 64** [Evoluta](#) PREMIUM
- 104** [Geostone](#) FLOOR AND MORE
- 142** [Glitch](#) FLOOR AND MORE
- 284** [Homey](#) PREMIUM
- 52** [Ibla](#) PREMIUM
- 40** [Journey](#) PREMIUM
- 22** [Limestone](#) PREMIUM
- 210** [Majestic](#) PREMIUM
- 198** [Majestic Pure Selection](#) PREMIUM
- 306** [Materia](#) FLOOR AND MORE
- 132** [More](#) FLOOR AND MORE
- 334** [Opus](#) CONTRACT
- 114** [Purestone](#) FLOOR AND MORE
- 162** [Shades](#) FLOOR AND MORE
- 340** [Suprema](#) CONTRACT
- 78** [Uniquestone](#) FLOOR AND MORE
- 174** [Urban](#) FLOOR AND MORE
- 352** [Venetian Marble](#) CONTRACT

CLICK

30x60

- 330** [Artdesia 2.0](#) CONTRACT
- 94** [Bits&Pieces](#) FLOOR AND MORE
- 124** [Castlestone](#) FLOOR AND MORE
- 344** [Concrete](#) CONTRACT
- 64** [Evoluta](#) PREMIUM
- 104** [Geostone](#) FLOOR AND MORE
- 142** [Glitch](#) FLOOR AND MORE
- 284** [Homey](#) PREMIUM
- 40** [Journey](#) PREMIUM
- 22** [Limestone](#) PREMIUM
- 306** [Materia](#) FLOOR AND MORE
- 132** [More](#) FLOOR AND MORE
- 114** [Purestone](#) FLOOR AND MORE
- 162** [Shades](#) FLOOR AND MORE
- 340** [Suprema](#) CONTRACT
- 78** [Uniquestone](#) FLOOR AND MORE
- 174** [Urban](#) FLOOR AND MORE
- 352** [Venetian Marble](#) CONTRACT

10x60

- 284** [Homey](#) PREMIUM
- 52** [Ibla](#) PREMIUM
- 22** [Limestone](#) PREMIUM

Sizes not rectified - Formati non rettificati

60,4x60,4

- 344** [Concrete](#) CONTRACT

45,4x45,4

- 344** [Concrete](#) CONTRACT

10x53

- 52** [Ibla](#) PREMIUM
- 22** [Limestone](#) PREMIUM
- 244** [Solorovere](#) FLOOR AND MORE
- 78** [Uniquestone](#) FLOOR AND MORE

15x90

- 272** [Cottage](#) FLOOR AND MORE
- 256** [Fleur de Bois](#) FLOOR AND MORE

22,5x90

- 272** [Cottage](#) FLOOR AND MORE
- 256** [Fleur de Bois](#) FLOOR AND MORE

20x120

- 272** [Cottage](#) FLOOR AND MORE
- 256** [Fleur de Bois](#) FLOOR AND MORE
- 244** [Solorovere](#) FLOOR AND MORE
- 266** [Soul](#) FLOOR AND MORE

30x120

- 52** [Ibla](#) PREMIUM

7,5x30

- 324** [Fragments](#) FLOOR AND MORE

17,5x20,5

- 162** [Shades](#) FLOOR AND MORE

± 20mm

90x90/20mm

- 306** [Materia](#) FLOOR AND MORE

60x120/20mm

- 344** [Concrete](#) CONTRACT
- 142** [Glitch](#) FLOOR AND MORE
- 22** [Limestone](#) PREMIUM

30x120/20mm

- 244** [Solorovere](#) FLOOR AND MORE

60x60/20mm

- 330** [Artdesia 2.0](#) CONTRACT
- 344** [Concrete](#) CONTRACT
- 142** [Glitch](#) FLOOR AND MORE
- 174** [Urban](#) FLOOR AND MORE

30,1x60,4

- 344** [Concrete](#) CONTRACT
- 114** [Purestone](#) FLOOR AND MORE



SHAPING THE FUTURE
STARTING FROM THE PAST

HISTORY

1962 L'inizio

Viene fondata a Maranello (Modena) "Industrie Ceramiche Piemme SPA", con 13 dipendenti e una produzione giornaliera di 40 mq di pavimenti e rivestimenti ceramici.

1977 Valentino

L'anno dell'accordo con il grande stilista Valentino.

1981 Sponsorizzazioni

Le sponsorizzazioni in formula uno con l'indimenticabile pilota della Ferrari Gilles Villeneuve hanno dato alla Piemme una visibilità mondiale.

2010 Era Digitale

Piemme adotta la tecnologia di decorazione digitale con investimenti dedicati ed impianti di ultima generazione.

2018 Tecnologia Synchro Digit Piemme®

Piemme sviluppa per prima nel comprensorio ceramico di Sassuolo la nuova tecnologia di stampa digitale "Synchro Digit Piemme®": la superficie strutturata delle piastrelle viene stampata digitalmente in perfetto sincrono con la decorazione (marmo, pietra, legno etc.).

2023 Nuova tecnologia industriale

A inizio 2023 abbiamo installato nuove tecnologie e macchinari con l'obiettivo di migliorare l'efficienza energetica e ridurre la nostra impronta sull'ambiente.

1962 The beginning

"Ceramiche Artistiche Piemme" is founded in Maranello (Modena), with 13 employees and a daily production of 40 sqm of ceramic floor and wall tiles.

1977 Valentino

The year of the agreement with the great designer Valentino.

1981 Sponsorships

The Formula 1 sponsorships with the unforgettable Ferrari driver Gilles Villeneuve have given Piemme a world visibility.

2010 Digital Era

Piemme adopts digital decoration technology with investments dedicated to the latest generation of production plants.

2018 Synchro Digit Piemme®

Piemme is the first to develop the new "Synchro Digit Piemme®" digital printing technology in the Sassuolo ceramic area: the structured surface of the tiles is digitally printed in perfect synchrony with the decoration.

2023 New manufacturing technology

In early 2023 we installed machinery with new technologies to improve energy efficiency and reduce our environmental footprint.

1962 Der Anfang

Gegründet in Maranello Industrie Ceramiche Piemme SPA mit 13 Mitarbeitern und einer täglichen Produktion von 40 qm Keramikböden und Bodenbelägen.

1977 Valentino

Das Jahr der Vereinbarung mit dem berühmten Designer Valentino.

1981 Sponsoring

Das Sponsoring in der Formel 1 mit dem unvergesslichen Ferrari-Piloten Gilles Villeneuve hat Piemme weltweit bekannt gemacht.

2010 Digitales Zeitalter

Piemme nimmt die Technologie der digitalen Dekoration mit engagierten Investitionen und Anlagen der neuesten Generation an.

2018 Die Synchro Digit Piemme®

Piemme Technologie wird geboren. Die Technologie, die es uns ermöglicht, ein Material mit einer einzigartigen hyperrealistischen Ästhetik zu erhalten.

2023 Neue industrielle technologie

Anfang 2023 haben wir neue Technologien und Maschinen eingebaut, um die Energieeffizienz zu verbessern und unsere Spur in der Umwelt zu reduzieren.

1962 Le début

Fondée à Maranello Industrie Ceramiche Piemme SPA avec 13 employés et une production quotidienne de 40 m2 de sols et revêtements en céramique.

1977 Valentino

L'année de l'accord avec le grand designer Valentino.

1981 Parrainages

Les parrainages en Formule 1 avec l'inoubliable pilote Ferrari Gilles Villeneuve ont donné à Piemme une visibilité mondiale.

2010 L'impressions Digitale

Piemme adopte la technologie de décoration numérique avec des investissements dédiés et des systèmes de dernière génération.

2018 La technologie Synchro Digit Piemme®

Piemme est née. La technologie qui nous permet d'obtenir un matériau à l'esthétique hyperréaliste unique en son genre.

2023 Nouvelle technologie industrielle

Début 2023, nous avons installé de nouvelles technologies et machines pour améliorer l'efficacité énergétique et réduire notre empreinte sur l'environnement.



**DESIGNED AND
MADE IN ITALY**

ABOUT US, MADE IN ITALY

Dal 1962 produciamo pavimenti e rivestimenti ceramici Made in Italy dallo stile inconfondibile. Le soluzioni che forniamo sono il frutto di tanti anni di attività fatta di ricerca, esperienza e passione. Ci avvaliamo di strumenti di ultima generazione e selezioniamo, per i nostri prodotti, materie prime di altissima qualità. Collaboriamo con aziende che condividono i nostri stessi valori e che si impegnano nell'offrire soluzioni e processi sempre meno impattanti a livello ambientale.

The protagonist of Made in Italy since 1962. The solutions we provide are the result of more than 60 years of activity made of research, experience, and passion. We use the latest generation of tools and select the highest quality raw materials for our products. We work with companies that share our values and are committed to offering solutions and processes that have less impact on the environment.

Seit 1962 produzieren wir keramische Wand- und Bodenbeläge „Made in Italy“ mit unverwechselbarer Qualität und Stil. Unsere Lösungen sind das Ergebnis von über 60 Jahren Forschung, Erfahrung und Leidenschaft. Wir verwenden modernste Werkzeuge und wählen für unsere Produkte Rohstoffe von höchster Qualität aus. Wir arbeiten mit Unternehmen zusammen, die unsere Werte teilen und sich dazu verpflichten, immer umweltfreundlichere Lösungen und Prozesse anzubieten.

Depuis 1962, nous produisons des sols et des revêtements en céramique Made in Italy d'une qualité et d'un style incomparables. Les solutions que nous proposons sont le résultat de plus de 60 ans d'activité faite de recherche, d'expérience et de passion. Nous utilisons des outils de dernière génération et sélectionnons des matières premières de la plus haute qualité pour nos produits. Nous collaborons avec des entreprises qui partagent nos mêmes valeurs et s'engagent à proposer des solutions et des processus ayant de moins en moins d'impact sur l'environnement.



GREEN DESIGN, REDEFINING TOMORROW



INDEX



[WATCH THE VIDEO](#)

SUSTAINABILITY

La riduzione dei fattori di rischio e il rispetto dell'ambiente sono alla base della nostra politica aziendale ed è per questo che intendiamo perseguire il rinnovamento a tutti i livelli, adottando tecnologie, metodi e approcci adeguati e all'avanguardia che permettono un miglioramento delle performance tecniche ed estetiche del prodotto e una riduzione dell'impatto ambientale. Gli investimenti in tecnologie 4.0 degli ultimi anni concorrono alla diminuzione del consumo di materia ed energia grazie al riutilizzo di reflui e scarti nel processo produttivo e alla riduzione delle emissioni.

Our company policy stays on the principles of reducing risk factors and respecting the environment. We intend to pursue renewal at all levels, adopting appropriate and cutting-edge technologies, methods, and approaches that allow an improvement of the technical and aesthetic performance of the product and a reduction of the environmental impact. Investments in 4.0 technologies contribute to the optimization of material and energy consumption thanks to the reuse of waste in the production process and to the reduction of emissions.

Die Reduzierung von Risikofaktoren und der Respekt vor der Umwelt sind die Grundlage unserer Unternehmenspolitik. Aus diesem Grund beabsichtigen wir, Erneuerungen auf allen Ebenen zu verfolgen und geeignete und hochmoderne Technologien, Methoden und Ansätze einzuführen, die eine Verbesserung der technischen und ästhetischen Leistung sowie Aspekte des Produkts und eine Reduzierung der Umweltbelastung ermöglichen. Die Investitionen in 4.0-Technologien der letzten Jahre tragen dazu bei, den Material- und Energieverbrauch durch die Wiederverwendung von Abwasser und Ausschüsse im Produktionsprozess zu senken und Emissionen zu reduzieren.

La réduction des facteurs de risque et le respect de l'environnement sont à la base de notre politique d'entreprise et c'est pourquoi nous entendons poursuivre le renouvellement à tous les niveaux, en adoptant des technologies, méthodes et approches appropriées et avant-gardistes qui permettent une amélioration des performances techniques et esthétiques du produit et une réduction de l'impact environnemental. Les investissements dans les technologies 4.0 de ces dernières années contribuent à la réduction de la consommation de matières et d'énergie grâce à la réutilisation des déchets dans le processus de production et contribuent à la réduction des émissions.



INDEX



**INNOVATE,
CREATE, CAPTIVATE**

INNOVATION

La continua attività di ricerca e sviluppo ci permette di accrescere costantemente il nostro know-how e di avvalerci di modalità produttive tecnologicamente avanzate e sempre all'avanguardia. L'uso di strumenti di ultima generazione, la versatilità e l'ampia gamma di colori, texture e finiture rendono i nostri prodotti esclusivi, ideati per offrire soluzioni progettuali ed estetiche sempre più performanti, in linea con le attuali tendenze d'arredo, e in grado di anticipare e soddisfare le diverse esigenze di architetti e designers.

Our continuous research and development activities enable us to constantly increase our know-how and make use of technologically advanced and cutting edge production methods. Thanks to the latest generation of ceramic manufacturing technology combined with a variety of available colors, different finishes, Piemme products are ideal for increasingly high-performance design and aesthetic solutions, in line with current furnishing trends, and capable of anticipating and satisfying the different needs of architects and designers.

Die kontinuierliche Forschung und Entwicklung ermöglicht es uns, unser Know-how ständig zu erweitern und technologisch fortschrittliche und immer auf dem neuesten Stand befindliche Produktionsmethoden zu nutzen. Die Verwendung modernster Produktionsanlagen, die Vielseitigkeit sowie das weite Farbsortiment, Texturen und Oberflächen machen unsere Produkte exklusiv. Sie sind darauf ausgelegt, immer leistungsfähigere Design- und Ästhetiklösungen zu bieten, die im Einklang mit den aktuellen Einrichtungstrends stehen und die unterschiedlichen Anforderungen von Architekten und Designern vorwegnehmen und erfüllen können.

Une activité continue de recherche et développement nous permet d'augmenter constamment notre savoir-faire et d'utiliser des méthodes de production technologiquement avancées et toujours à l'avant-garde. L'utilisation d'outils de dernière génération, la polyvalence et la large gamme de couleurs, textures et finitions rendent nos produits exclusifs, conçus pour offrir des solutions design et esthétiques de plus en plus performantes, en ligne avec les tendances actuelles de l'ameublement, et capables d'anticiper et de satisfaire les différents besoins des architectes et des designers.

SYNCHRO DIGIT PIEMME® TECHNOLOGY



La superficie con struttura digitale sincronizzata Synchro Digit Piemme® sviluppata in esclusiva negli stabilimenti Piemme, unita alla stampa ad alta risoluzione a 300 dpi, consentono di ottenere un materiale dall'estetica iperrealista unico nel suo genere, di eccellente valenza tecnica ed estetica. La superficie tridimensionale non è più formata per pressatura ed è quindi libera dai vincoli ripetitivi dei classici stampi per ceramica e, inoltre, è perfettamente sincronizzata con la grafica di superficie:

The Synchro Digit Piemme® synchronized digital structure surface, exclusively developed in Piemme plants, combined with high resolution printing at 300 DPI, provides a material with a uniquely hyper-realistic appearance and outstanding technical and aesthetic qualities. The three-dimensional surface is no longer formed by pressing and is therefore free from the repetitive constraints of classic ceramic moulds; moreover, it is perfectly synchronized with the graphics on the surface.

Die Oberfläche mit synchronisierter digitaler Struktur Synchro Digit Piemme®, exklusiv bei Piemme entwickelt, in Verbindung mit der Presse in hoher Auflösung 300 dpi, ermöglichen ein Material von einer hyperrealistischen Ästhetik, einzigartig in seiner Art, von ausgezeichneter Qualität, Technik und Ästhetik. Die dreidimensionale Fläche wird nicht mehr durch die Pressen geformt, und ist somit frei von den üblichen Zwängen der klassischen Formen der Keramik; sie ist auch perfekt mit der Grafik der Oberfläche synchronisiert.

La surface avec structure synchronisée numérique Synchro Digit Piemme®, développée en exclusivité dans les établissements de Piemme, est associée à l'impression haute résolution à 300 dpi. Ces deux éléments permettent d'obtenir un matériau à l'esthétique hyperréaliste unique et d'une excellente valeur technique et esthétique. La surface tridimensionnelle n'est plus formée par pressage et n'est donc pas soumise aux contraintes répétitives des moulages classiques pour céramique; de plus, elle est parfaitement synchronisée avec le graphique de la surface.

WHERE TECHNOLOGY MEETS
THE ART OF CERAMICS

VANTAGGI DI SYNCHRO DIGIT PIEMME®:

- **Struttura con grafiche e dettagli ad alta definizione di 300dpi**
- **Sincronizzazione totale con la stampante digitale ad inchiostro**
- **Smalti a base acqua con basse emissioni**
- **Ridotto consumo di acqua per la pulizia**
- **Efficienza energetica**

ADVANTAGES OF SYNCHRO-DIGIT PIEMME® TECHNOLOGY:

- Structure with 300dpi high-definition graphics.
- Full synchronization with the digital ink printer
- Water-based glazes with low VOC emissions.
- Reduced water consumption for cleaning
- Energy efficiency

VORTEILE VON SYNCHRO DIGIT PIEMME®:

- Struktur mit Grafiken und High-Definition-Details in 300dpi Auflösung
- Vollständige Synchronisation mit dem digitalen Tintenstrahldrucker
- Wasserbasierte Glasuren mit geringen Emissionen
- Reduzierter Wasserverbrauch für die Reinigung
- Energieeffizienz

LES PLUS DE SYNCHRO DIGIT PIEMME®:

- Structure avec graphismes haute définition et détails de 300dpi
- Synchronisation totale avec l'imprimante à encre numérique
- Émaux à base d'eau à faibles émissions
- Consommation d'eau réduite pour le nettoyage
- Efficacité énergétique

▶ [WATCH THE VIDEO](#)



**ELEVATE
YOUR SPACE**

MAKRO SLABS PROJECT

Le nostre magnifiche lastre, disponibili in diversi effetti e colori, sono il perfetto connubio tra estetica e funzionalità. I grandi formati offrono molteplici vantaggi: garantiscono una continuità visiva molto gradevole e di grande impatto estetico, ideale per uno stile moderno e minimalista. Grazie alla loro dimensione, inoltre, le lastre sono resistenti agli urti, alla corrosione e ad altri danni meccanici, adatte sia a pavimento che a rivestimento in ambienti ad alto traffico o esposti a diverse condizioni atmosferiche. Per ultimo, l'assenza di fughe offre a livello visivo la percezione di spazi più ampi e ordinati oltre che una maggiore facilità di pulizia e manutenzione.

Our slabs, available in different effects and colors, are the perfect combination of aesthetics and functionality. Large formats offer multiple advantages: They guarantee a very pleasant visual continuity and great aesthetic effect, ideal for a modern and minimalist style. The slabs are resistant to impact, corrosion, and other potential mechanical damage; they are suitable for both floors and walls in high-traffic environments and they can sustain different atmospheric conditions. The minimum grout joint offers the perception of even larger and organized spaces as well as ease cleaning and maintenance.

Unsere prächtigen Platten, die in verschiedenen Effekten und Farben erhältlich sind, stellen die perfekte Verbindung von Ästhetik und Funktionalität dar. Die großen Formate bieten zahlreiche Vorteile: Sie gewährleisten eine äußerst angenehme visuelle Kontinuität und eine beeindruckende ästhetische Wirkung, ideal für einen modernen und minimalistischen Stil. Dank ihrer Größe sind die Platten zudem stoßfest, korrosionsbeständig und gegen andere mechanische Schäden geschützt. Sie eignen sich sowohl für den Bodenbelag als auch für die Wandverkleidung in stark frequentierten Bereichen oder in Umgebungen, die der Witterung ausgesetzt sind. Schließlich vermittelt die Fugenabwesenheit visuell den Eindruck von großzügigeren und ordentlicheren Räumen, und bietet zugleich eine einfachere Reinigung und Wartung.

Nos magnifiques dalles, disponibles en différents effets et couleurs, sont la combinaison parfaite entre esthétique et fonctionnalité. Les grands formats offrent de multiples avantages : ils garantissent une continuité visuelle très agréable et un grand impact esthétique, idéal pour un style moderne et minimaliste. De plus, grâce à leurs dimensions, les dalles sont résistantes aux chocs, à la corrosion et autres dommages mécaniques, adaptées aussi bien aux sols qu'aux murs dans des environnements à fort trafic ou exposés à différentes conditions atmosphériques. Enfin, l'absence de joints offre visuellement la perception d'espaces plus grands et plus ordonnés ainsi qu'une plus grande facilité de nettoyage et d'entretien.

CERAMICHE PIEMME

FLOOR AND MORE

Ceramiche Piemme - Floor and More, rappresenta: tecnologia, essenzialità, qualità e capacità di adattarsi trasversalmente alle scelte di stile, ma soprattutto di vita, dei propri clienti.

Ceramiche Piemme - Floor and More now represents: technology, minimalism, quality and the ability to adapt transversally to the choices made by its customers in terms of both style and, above all, lifestyle.

Ceramiche Piemme - Floor and More steht für: Technologie, Wesentlichkeit, Qualität und vielfältige Anpassungsfähigkeit an den Stil und die Lebensweise der Kunden.

Ceramiche Piemme - Floor and More est synonyme de technologie, qualité et capacité de s'adapter transversalement aux choix de style, mais surtout de vie de ses clients.

CLICK



20 [STONE EFFECT](#)

140 [CEMENT EFFECT](#)

182 [MARBLE EFFECT](#)

242 [WOOD EFFECT](#)

282 [CONTEMPORARY](#)



STONE EFFECT

Effetto Pietra / Natursteinoptik / Effet Pierre



CLICK

- 22 [Limestone](#) PREMIUM /
- 40 [Journey](#) PREMIUM /
- 52 [Ibla](#) PREMIUM /
- 64 [Evoluta](#) PREMIUM /
- 78 [Uniquestone](#) FLOOR AND MORE /
- 94 [Bits&Pieces](#) FLOOR AND MORE /
- 104 [Geostone](#) FLOOR AND MORE /
- 114 [Purestone](#) FLOOR AND MORE /
- 124 [Castlestone](#) FLOOR AND MORE /
- 132 [More](#) FLOOR AND MORE



Limestone

La bellezza della pietra calcarea nata dai fondali marini e lavorata nel corso del tempo dall'acqua. Dalla colorazione profonda e dalle piccole imperfezioni che la rendono unica. Peculiarità di una pietra naturale che vengono magistralmente riprodotte in questa nuova proposta.

The beauty of limestone, sourced from the seabed where it has been shaped over time by water, with its rich coloring and small imperfections making it a unique and timeless material, has been masterfully recreated in this new collection.

Die Schönheit des Kalksteins, der sich im Meeresboden bildet und im Laufe der Zeit vom Wasser geformt wird, mit seinen tiefen Farben und den kleinen Unvollkommenheiten, die ihn einzigartig machen. Besonderheiten eines Natursteins, die in diesem neuen Vorschlag meisterhaft reproduziert werden.

La beauté de la pierre calcaire, née des fonds marins et travaillée au fil du temps par l'eau, la couleur profonde et les petites imperfections qui la rendent unique. Caractéristiques d'une pierre naturelle qui sont magistralement reproduites dans cette nouvelle proposition.

6

Colori
Colours
Farben
Couleurs

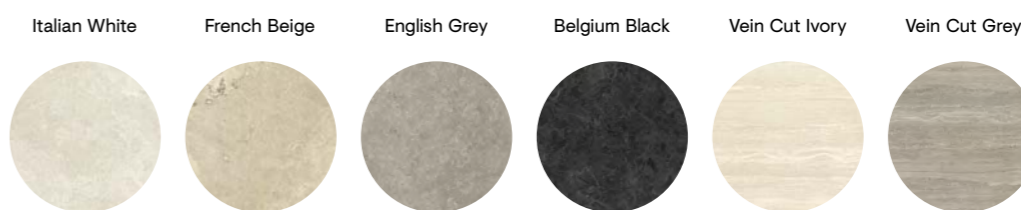

7

Formati
Sizes
Formate
Formats

120×280 48"×110"	120×120 48"×48"	60×120 24"×48"	60×60 24"×24"	30×60 12"×24"	10×60 4"×24"	10×53 4"×20"
---------------------	--------------------	-------------------	------------------	------------------	-----------------	-----------------

4

Superfici
Surfaces
Oberflächen
Surfaces

Naturale Lappato Antislip Grip

1

Strutture 3D
3D structures
Strukturen
Décorations en relief

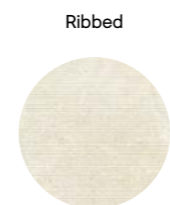

i



Tecnologia - Technology - Technologie:
Synchro Digit Piemme®
Superficie con struttura digitale sincronizzata
Synchronized digital structured surface
Im synchronisierten Digitaldruckverfahren hergestellte 3D-Oberfläche
Surface avec texture et finition par impression numérique synchronisée

Gres fine porcellanato ad impasto colorato
Coloured-body fine porcelain stoneware
Feinsteinzeug aus farbiger Masse
Grès cérame fin à pâte colorée

Effetto Pietra
Stone Look
Natursteinoptik
Effet Pierre

Rivestimento
Wall Tiles
Wandfliesen
Revêtement

Pavimento
Floor Tiles
Bodenfliesen
Sol

Ripresa grafica tra le diverse lastre rettificata contenuta entro le tolleranze previste dalla norma. Per un corretto allineamento si consiglia di utilizzare una fuga di 2 mm.
Graphic representation between the rectified tiles is contained within the tolerances provided by the standard. For a correct alignment it is recommended to use a 2 mm joint.
Grafische Darstellung zwischen den verschiedenen rektifizierten Platten innerhalb der in der Norm vorgesehenen Toleranzen. Für eine korrekte Anpassung wird eine Fuge von 2mm empfohlen.
Reproduction graphique entre les différents carreaux rectifiés dans les limites des tolérances prévues par la norme. Pour un alignement correct, il est recommandé d'utiliser joints de 2 mm.

▶ WATCH THE VIDEO



Italian White



120x280
05482 | Italian White Nat/Ret



60x120
Synchro Digit Piemme® Technology
05508 | Italian White Nat/Ret
05515 | Italian White Lap/Ret
05574 | Italian White Antislip/Ret
05576 | Italian White Grip/Ret \pm 20mm



60x60
Synchro Digit Piemme® Technology
05499 | Italian White Nat/Ret
05504 | Italian White Lap/Ret
05572 | Italian White Antislip/Ret



30x60
Synchro Digit Piemme® Technology
05491 | Italian White Nat/Ret
05495 | Italian White Lap/Ret
05570 | Italian White Antislip/Ret



10x60
05541 | Listoncino Italian White Nat/Ret
05545 | Listoncino Italian White Lap/Ret



10x53
05549 | Chevron Italian White Nat/Ret
05554 | Chevron Italian White Lap/Ret



30x30
05586 | Mosaico Mix Italian White Lap/Nat



120x120
05477 | Italian White Nat/Ret



60x120
05598 | Ribbed Italian White Nat/Ret



28,2x28,5
05590 | Opus Mix Italian White Lap/Nat

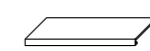
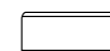



Gres fine porcellanato ad impasto colorato / Tecnologia digitale
Coloured-body fine porcelain stoneware / Digital technology

Feinsteinzeug aus farbiger Masse / Digital Technologie
Grès cérame fin à pâte colorée / Technologie numérique

French Beige



120x280
05483 | French Beige Nat/Ret



60x120
Synchro Digit Piemme® Technology
05509 | French Beige Nat/Ret
05516 | French Beige Lap/Ret
05575 | French Beige Antislip/Ret
05577 | French Beige Grip/Ret $\geq 20\text{mm}$



60x60
Synchro Digit Piemme® Technology
05501 | French Beige Nat/Ret
05505 | French Beige Lap/Ret
05573 | French Beige Antislip/Ret



30x60
Synchro Digit Piemme® Technology
05492 | French Beige Nat/Ret
05496 | French Beige Lap/Ret
05571 | French Beige Antislip/Ret



10x60
05542 | Listoncino French Beige Nat/Ret
05546 | Listoncino French Beige Lap/Ret

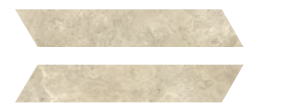

10x53
05551 | Chevron French Beige Nat/Ret
05555 | Chevron French Beige Lap/Ret



30x30
05587 | Mosaico Mix French Beige Lap/Nat



28,2x28,5
05591 | Opus Mix French Beige Lap/Nat



120x120
05478 | French Beige Nat/Ret



60x120
05599 | Ribbed French Beige Nat/Ret

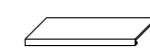
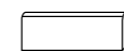



English Grey



120x280
05484 | English Grey Nat/Ret



60x120
Synchro Digit Piemme® Technology
05511 | English Grey Nat/Ret
05517 | English Grey Lap/Ret
05578 | English Grey Grip/Ret ± 20mm



60x60
Synchro Digit Piemme® Technology
05502 | English Grey Nat/Ret
05506 | English Grey Lap/Ret

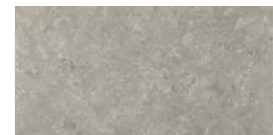

30x60
Synchro Digit Piemme® Technology
05493 | English Grey Nat/Ret
05497 | English Grey Lap/Ret



10x60
05543 | Listoncino English Grey Nat/Ret
05547 | Listoncino English Grey Lap/Ret



10x53
05552 | Chevron English Grey Nat/Ret
05556 | Chevron English Grey Lap/Ret



30x30
05588 | Mosaico Mix English Grey Lap/Nat



28,2x28,5
05592 | Opus Mix English Grey Lap/Nat



120x120
05479 | English Grey Nat/Ret



60x120
05601 | Ribbed English Grey Nat/Ret

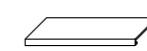
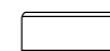



Belgium Black



120x280
05485 | Belgium Black Nat/Ret



60x120
Synchro Digit Piemme® Technology
05512 | Belgium Black Nat/Ret
05518 | Belgium Black Lap/Ret



60x60
Synchro Digit Piemme® Technology
05503 | Belgium Black Nat/Ret
05507 | Belgium Black Lap/Ret



30x60
Synchro Digit Piemme® Technology
05494 | Belgium Black Nat/Ret
05498 | Belgium Black Lap/Ret



120x120
05481 | Belgium Black Nat/Ret



10x60
05544 | Listoncino Belgium Black Nat/Ret
05548 | Listoncino Belgium Black Lap/Ret

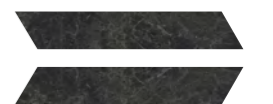

10x53
05553 | Chevron Belgium Black Nat/Ret
05557 | Chevron Belgium Black Lap/Ret

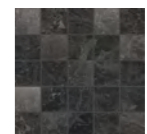

30x30
05589 | Mosaico Mix Belgium Black Lap/Nat

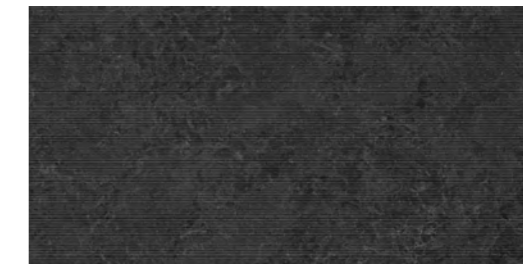

60x120
05602 | Ribbed Belgium Black Nat/Ret



28,2x28,5
05593 | Opus Mix Belgium Black Lap/Nat

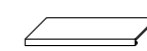
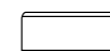



Vein Cut Ivory



120x280
05526 | Vein Cut Ivory Nat/Ret



60x120
Synchro Digit Piemme® Technology
05522 | Vein Cut Ivory Nat/Ret
05524 | Vein Cut Ivory Lap/Ret



Vein Cut Grey



120x280
05527 | Vein Cut Grey Nat/Ret



60x120
Synchro Digit Piemme® Technology
05523 | Vein Cut Grey Nat/Ret
05525 | Vein Cut Grey Lap/Ret



Imballi







Packing
Verpackung
Emballage

Formati Sizes	P	± MM							
			Pezzi Scatola Pieces/Box Stck/Karton Carreaux/Boîte	Mq/Scatola Sqmt/Box Qm/Karton M2/Boîte	Kg/Scatola Kgs/Box Kg/Karton Kg/Boîte	Scatole/Paletta Boxes/Pallet Karton/Palette Boîte/Palette	Mq/Paletta Sqmt/Pallet Qm/Pallet M2/Palette	Kg/Paletta Kgs/Pallet Kg/Pallet Kg/Palette	Formato Paletta Size Pallet Format Pallet Dim. Palette
120*280 (48"*110") Nat/Ret	P	6	1	3,36	46,50	20	67,20	930	143x294x35
120*120 (48"*48") Nat/Ret	P	8,5	2	2,88	55,00	24	69,12	1320	135x122x68
60*120 (24"*48") Nat/Ret - Lap/Ret - Antislip/Ret	P	8,5	2	1,44	28,00	36	51,84	1008	122x82x75
60*120 (24"*48") Grip/Ret	P	20	1	0,72	33,00	36	25,92	1188	122x96x75
60*120 (24"*48") Ribbed Nat/Ret	P	8,5	2	1,44	28,00	36	51,84	1008	122x82x75
60*60 (24"*24") Nat/Ret - Lap/Ret - Antislip/Ret	P	8,5	4	1,44	26,00	40	57,6	1040	120x80x75
30*60 (12"*24") Nat/Ret - Lap/Ret - Antislip/Ret	P	8,5	7	1,26	22,50	48	60,48	1080	120x80x75
28,2*28,5 (11"*11¼") Opus Mix Lap/Nat	P	8,5	6	0,48	9,50	60	-	-	-
30*30 (12"*12") Mosaico Mix Lap/Nat	P	8,5	5	0,45	8,50	60	-	-	-
Pezzi Speciali / Special Pieces									
33*120 (13"*48") Gradino Costa Retta Nat/Ret	P	8,5	2	0,79	15,60	20	-	-	-
4,5*60 (1¼"*24") Battiscopa Nat/Ret - Lap/Ret	P	8,5	14	0,38 m.l. 8,40	7,10	80	-	-	-

Limestone

Riepilogo Gamma

Collection
Serie
Gamme

	Formati Sizes	Formati								DIN 51130	DIN 51097	DCOF	BS EN 7976-2		
		120x280 48"x110"	120x120 48"x48"	60x120 24"x48"	60x120 24"x48"	60x60 24"x24"	30x60 12"x24"	Listoncino 10x60 4"x24"	Chevron 10x53 4"x20"						
		± 6	± 8,5	± 8,5	± 20	± 8,5	± 8,5	± 8,5	± 8,5						
 Italian White	Nat/Ret	05482	05477	05508		05499	05491	05541	05549	V2	R10	A+B	>0.42	wet, dry>36	
	Lap/Ret			05515		05504	05495	05545	05554						
	Antislip/Ret			05574		05572	05570					R11	A+B+C	>0.42	wet, dry>36
	Grip/Ret				05576							R11	A+B+C	>0.42	wet, dry>36
 French Beige	Nat/Ret	05483	05478	05509		05501	05492	05542	05551	V2	R10	A+B	>0.42	wet, dry>36	
	Lap/Ret			05516		05505	05496	05546	05555						
	Antislip/Ret			05575		05573	05571					R11	A+B+C	>0.42	wet, dry>36
	Grip/Ret				05577							R11	A+B+C	>0.42	wet, dry>36
 English Grey	Nat/Ret	05484	05479	05511		05502	05493	05543	05552	V2	R10	A+B	>0.42	wet, dry>36	
	Lap/Ret			05517		05506	05497	05547	05556						
	Grip/Ret				05578							R11	A+B+C	>0.42	wet, dry>36
 Belgium Black	Nat/Ret	05485	05481	05512		05503	05494	05544	05553	V2	R10	A+B	>0.42	wet, dry>36	
	Lap/Ret			05518		05507	05498	05548	05557						
 Vein Cut Ivory	Nat/Ret	05526		05522						V2	R10	A+B	>0.42	wet, dry>36	
	Lap/Ret			05524											
 Vein Cut Grey	Nat/Ret	05527		05523						V2	R10	A+B	>0.42	wet, dry>36	
	Lap/Ret			05525											

Limestone





Riepilogo Gamma

Collection
Serie
Gamme

CLICK

PDF Merchandising



	Formati Sizes	Strutture 3D 3D Structures		Pezzi Speciali Special Pieces		
		Ribbed 60x120 24"x48"	Mosaico Mix 30x30 12"x12"	Opus Mix 28,2x28,5 11"x11¼"	Gradino Costa Retta 33x120 13"x48"	Battiscopa 4,5x60 1¼"x24"
		± 8,5	± 8,5	± 8,5	± 8,5	± 8,5
 Italian White	Nat/Ret	05598			05566	05558
	Lap/Ret					05562
	Lap/Nat		05586	05590		
 French Beige	Nat/Ret	05599			05567	05559
	Lap/Ret					05563
	Lap/Nat		05587	05591		
 English Grey	Nat/Ret	05601			05568	05560
	Lap/Ret					05564
	Lap/Nat		05588	05592		
 Belgium Black	Nat/Ret	05602			05569	05561
	Lap/Ret					05565
	Lap/Nat		05589	05593		



Journey

Interpretata come un viaggio attraverso i paesaggi del Nord Europa, Journey è la sintesi di tutte quelle caratteristiche che permettono di definire spazi accoglienti e naturali in grado di esprimere, attraverso colori, superfici, formati e decori, i gusti contemporanei del mondo dell'interior design.

Interpreted as a journey through the landscapes of Northern Europe, Journey is the synthesis of all those characteristics that allow to define welcoming and natural areas able to express, through colors, surfaces, sizes and decorations, the contemporary taste of the world of interior design.

Journey ist die Synthese all jener Eigenschaften einer Reise durch die Landschaften Nordeuropas, die es ermöglichen, einladende und natürliche Räume zu definieren, die in der Lage sind, durch Farben, Oberflächen, Formate und Dekorationen den zeitgenössischen Geschmack der Innenarchitektur auszudrücken.

Interprétée comme un voyage à travers les paysages de l'Europe du Nord, la série Journey est la synthèse de toutes les caractéristiques qui permettent de définir des espaces accueillants et naturels en mesure d'exprimer, à travers des couleurs, des surfaces, formats et décors, les goûts contemporains du monde du design d'intérieur.

4

Colori
Colours
Farben
Couleurs



4

Formati
Sizes
Formate
Formats

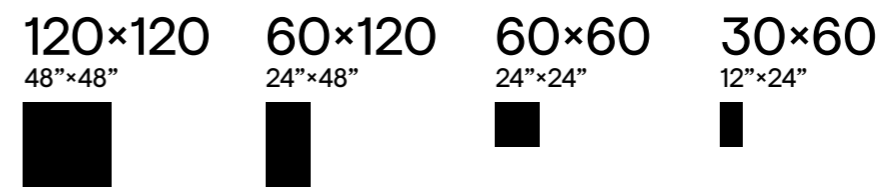

3

Superfici
Surfaces
Oberflächen
Surfaces

Naturale Silk Antislip

4

Strutture 3D
3D structures
Strukturen
Décorations en relief

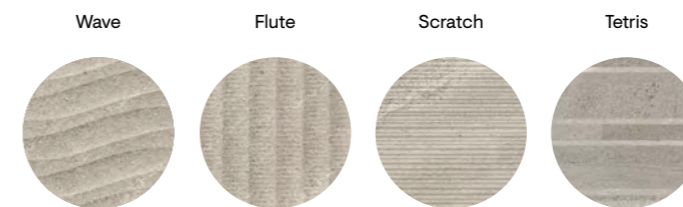

i



Tecnologia - Technology - Technologie:
Synchro Digit Piemme®
Superficie con struttura digitale sincronizzata
Synchronized digital structured surface
Im synchronisierten Digitaldruckverfahren
hergestellte 3D-Oberfläche
Surface avec texture et finition par
impression numérique synchronisée

Gres fine porcellanato ad impasto colorato
Coloured-body fine porcelain stoneware
Feinsteinzeug aus farbiger Masse
Grès cérame fin à pâte colorée

Effetto Pietra
Stone Look
Natursteinoptik
Effet Pierre

Rivestimento
Wall Tiles
Wandfliesen
Revêtement

Pavimento
Floor Tiles
Bodenfliesen
Sol

Ripresa grafica tra le diverse lastre rettificata contenuta entro le tolleranze previste dalla norma. Per un corretto allineamento si consiglia di utilizzare una fuga di 2 mm.
Graphic representation between the rectified tiles is contained within the tolerances provided by the standard. For a correct alignment it is recommended to use a 2 mm joint.
Grafische Darstellung zwischen den verschiedenen rektifizierten Platten innerhalb der in der Norm vorgesehenen Toleranzen. Für eine korrekte Anpassung wird eine Fuge von 2mm empfohlen.
Reproduction graphique entre les différents carreaux rectifiés dans les limites des tolérances prévues par la norme. Pour un alignement correct, il est recommandé d'utiliser joints de 2 mm.

▶ WATCH THE VIDEO



Otta

Per un risultato di posa ottimale si consiglia di prelevare le piastrelle da 5/6 scatole contemporaneamente.

For best installation results, we suggest taking the tiles from 5/6 boxes at the same time.



120×120

04953 | Journey Otta Nat/Ret
05299 | Journey Otta Silk/Ret



60×60

04717 | Journey Otta Nat/Ret
04722 | Journey Otta Silk/Ret



30×60

04726 | Journey Otta Nat/Ret
04731 | Journey Otta Silk/Ret



60×120

04671 | Journey Otta Nat/Ret
04678 | Journey Otta Silk/Ret



60×120

04688 | Journey Scratch Otta Nat/Ret
(Synchro Digit Piemme® Technology)



30×60

04735 | Journey Wave Otta Nat/Ret



60×120

***04697** | Journey Otta Antislip/Ret
(Synchro Digit Piemme® Technology)



60×120

04687 | Journey Tetris Warm Nat/Ret
(Synchro Digit Piemme® Technology)



30×60

04739 | Journey Flute Otta Nat/Ret

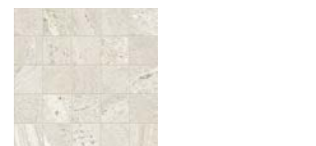

30×30

04937 | Journey Mosaico Otta Nat/Ret

* L'Articolo non ha verso di posa
Item with no laying direction
Artikel ohne Verlegerichtung
Article sans sens de pose

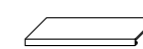
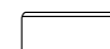



Sarek

Per un risultato di posa ottimale si consiglia di prelevare le piastrelle da 5/6 scatole contemporaneamente.

For best installation results, we suggest taking the tiles from 5/6 boxes at the same time.



120×120

04954 | Journey Sarek Nat/Ret
05301 | Journey Sarek Silk/Ret



60×60

04718 | Journey Sarek Nat/Ret
04723 | Journey Sarek Silk/Ret



30×60

04727 | Journey Sarek Nat/Ret
04732 | Journey Sarek Silk/Ret



60×120

04673 | Journey Sarek Nat/Ret
04681 | Journey Sarek Silk/Ret



60×120

04689 | Journey Scratch Sarek Nat/Ret
(Synchro Digit Piemme® Technology)



30×60

04736 | Journey Wave Sarek Nat/Ret



60×120

***04699** | Journey Sarek Antislip/Ret
(Synchro Digit Piemme® Technology)



60×120

04687 | Journey Tetris Warm Nat/Ret
(Synchro Digit Piemme® Technology)



30×60

04741 | Journey Flute Sarek Nat/Ret



30×30

04938 | Journey Mosaico Sarek Nat/Ret

* L'articolo non ha verso di posa
Item with no laying direction
Artikel ohne Verlegerichtung
Article sans sens de pose

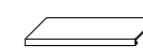
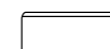



Cumbria

Per un risultato di posa ottimale si consiglia di prelevare le piastrelle da 5/6 scatole contemporaneamente.

For best installation results, we suggest taking the tiles from 5/6 boxes at the same time.



120x120

04955 | Journey Cumbria Nat/Ret
05302 | Journey Cumbria Silk/Ret



60x60

04719 | Journey Cumbria Nat/Ret
04724 | Journey Cumbria Silk/Ret



30x60

04728 | Journey Cumbria Nat/Ret
04733 | Journey Cumbria Silk/Ret



60x120

04674 | Journey Cumbria Nat/Ret
04682 | Journey Cumbria Silk/Ret



60x120

04691 | Journey Scratch Cumbria Nat/Ret
(Synchro Digit Piemme® Technology)



30x60

04737 | Journey Wave Cumbria Nat/Ret



60x120

***04701** | Journey Cumbria Antislip/Ret
(Synchro Digit Piemme® Technology)



60x120

04685 | Journey Tetris Cold Nat/Ret
(Synchro Digit Piemme® Technology)



30x60

04742 | Journey Flute Cumbria Nat/Ret



30x30

04939 | Journey Mosaico Cumbria Nat/Ret

* L'Articolo non ha verso di posa
Item with no laying direction
Artikel ohne Verlegerichtung
Article sans sens de pose

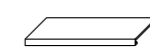
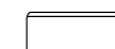



Lomond

Per un risultato di posa ottimale si consiglia di prelevare le piastrelle da 5/6 scatole contemporaneamente.

For best installation results, we suggest taking the tiles from 5/6 boxes at the same time.



120x120

04956 | Journey Lomond Nat/Ret
05303 | Journey Lomond Silk/Ret



60x60

04721 | Journey Lomond Nat/Ret
04725 | Journey Lomond Silk/Ret



30x60

04729 | Journey Lomond Nat/Ret
04734 | Journey Lomond Silk/Ret



60x120

04676 | Journey Lomond Nat/Ret
04683 | Journey Lomond Silk/Ret



60x120

04693 | Journey Scratch Lomond Nat/Ret
(Synchro Digit Piemme® Technology)

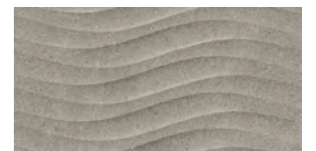

30x60

04738 | Journey Wave Lomond Nat/Ret



60x120

***04705** | Journey Lomond Antislip/Ret
(Synchro Digit Piemme® Technology)



60x120

04685 | Journey Tetris Cold Nat/Ret
(Synchro Digit Piemme® Technology)



30x60

04743 | Journey Flute Lomond Nat/Ret



30x30

04940 | Journey Mosaico Lomond Nat/Ret

* L'articolo non ha verso di posa
Item with no laying direction
Artikel ohne Verlegerichtung
Article sans sens de pose

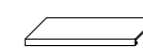
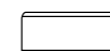

CLICK

PDF Merchandising



Formati Sizes	P	± MM							Formato Paletta Size Pallet Format Pallet Dim. Palette
			Pezzi Scatola Pieces/Box Stck/Karton Carreaux/Boîte	Mq/Scatola Sqmt/Box Qm/Karton M2/Boîte	Kg/Scatola Kgs/Box Kg/Karton Kg/Boîte	Scatole/Paletta Boxes/Pallet Karton/Palette Boîte/Palette	Mq/Paletta Sqmt/Pallet Qm/Pallet M2/Palette	Kg/Paletta Kgs/Pallet Kg/Pallet Kg/Palette	
120x120 (48"x48") Nat/Ret - Silk/Ret	P	9,5	2	2,880	58,00	22	63,36	1276,00	135x122x68
60x120 (24"x48") Nat/Ret - Silk/Ret - Antislip/Ret	P	9,5	2	1,440	31,00	30	43,20	930,00	122x82x75
60x60 (24"x24") Nat/Ret - Silk/Ret	P	9,5	4	1,440	29,00	32	46,08	928,00	120x80x75
30x60 (12"x24") Nat/Ret - Silk/Ret	P	9,5	7	1,260	25,30	40	50,40	1012,00	120x80x75
60x120 (24"x48") Tetris Nat/Ret	P	9,5	2	1,440	31,00	30	43,20	930,00	122x82x75
60x120 (24"x48") Scratch Nat/Ret	P	9,5	2	1,440	31,00	30	43,20	930,00	122x82x75
30x60 (12"x24") Wave Nat/Ret	P	9,5	7	1,260	26,30	32	40,32	841,60	120x80x75
30x60 (12"x24") Flute Nat/Ret	P	9,5	7	1,260	26,30	32	40,32	841,60	120x80x75
30x30 (12"x12") Mosaico Nat/Ret	P	9,5	5	0,45	8,50	60	-	-	-
Pezzi Speciali / Special Pieces									
33x120 (13"x48") Gradino Costa Retta Nat/Ret - Silk/Ret	P	9,5	2	0,792	18,50	20	-	-	-
4,5x60 (1 7/8"x24") Battiscopa Nat/Ret - Silk/Ret	P	9,5	14	0,378	8,00	80	-	-	-

	Formati Sizes	Formati Sizes					Strutture 3D 3D Structures					Pezzi Speciali Special Pieces					
		120x120 48"x48"	60x120 24"x48"	60x60 24"x24"	30x60 12"x24"	DIN 51130	DIN 51097	DCOF	BS EN 7976-2	AS 4586 2013	Tetris 60x120 24"x48"	Scratch 60x120 24"x48"	Wave 30x60 12"x24"	Flute 30x60 12"x24"	Mosaico 30x30 12"x12"	Gradino Costa Retta 33x120 13"x48"	Battiscopa 4,5x60 1 7/8"x24"
Otta	Nat/Ret	04953	04671	04717	04726	R10	B	>0.42	wet, dry >36	P3	04687	04688	04735	04739	04937	04941	04929
	Silk/Ret	05299	04678	04722	04731	V2		>0.42								04945	04933
	Antislip/Ret		04697			R11	A+B+C	>0.42	wet, dry >36	P4							
Sarek	Nat/Ret	04954	04673	04718	04727	R10	B	>0.42	wet, dry >36	P3	04687	04689	04736	04741	04938	04942	04930
	Silk/Ret	05301	04681	04723	04732	V2		>0.42								04946	04934
	Antislip/Ret		04699			R11	A+B+C	>0.42	wet, dry >36	P4							
Cumbria	Nat/Ret	04955	04674	04719	04728	R10	B	>0.42	wet, dry >36	P3	04685	04691	04737	04742	04939	04943	04931
	Silk/Ret	05302	04682	04724	04733	V2		>0.42								04947	04935
	Antislip/Ret		04701			R11	A+B+C	>0.42	wet, dry >36	P4							
Lomond	Nat/Ret	04956	04676	04721	04729	R10	B	>0.42	wet, dry >36	P3	04685	04693	04738	04743	04940	04944	04932
	Silk/Ret	05303	04683	04725	04734	V2		>0.42								04948	04936
	Antislip/Ret		04705			R11	A+B+C	>0.42	wet, dry >36	P4							



Ibla

Ibla è una serie in gres porcellanato di ultima generazione, estremamente ricca nell'assortimento che offre al progettista innumerevoli soluzioni d'utilizzo, tutte perfettamente coordinabili tra loro per realizzare un progetto architettonico di altissimo livello sotto l'aspetto sia tecnico che estetico, coniugando la grande tradizione creativa all'eccellente innovazione tecnologica e produttiva Italiana.

Ibla is a latest-generation porcelain stoneware series with an extremely rich assortment, offering the architect countless potentials for use, all perfectly matchable as the basis for architectural projects with the highest technical and aesthetic values, as a great creative tradition is paired with Italian excellence in technological and production innovation.

Ibla ist eine Feinsteinzeugserie, die dem jüngsten Stand der Technik entspricht. Ihr umfangreiches Sortiment bietet Architekten und Planern zahlreiche, perfekt kombinierbare Lösungen für Architekturprojekte, die technisch und ästhetisch höchste Ansprüche erfüllen, und in denen sich Kreativität mit innovativer Technik und Produktion im Zeichen italienischer Exzellenz verbinden.

Ibla est une série en grès cérame de dernière génération. La grande richesse de son assortiment offre au concepteur d'innombrables solutions d'utilisation, toutes parfaitement coordonnées : c'est l'assurance de pouvoir créer un projet architectural d'un niveau technique et esthétique de haute volée, conjuguant la grande tradition créative avec l'excellence italienne en matière d'innovation, de technologie et de production.

4

Colori
Colours
Farben
Couleurs

Ibla Linfa



Ibla Colofonia

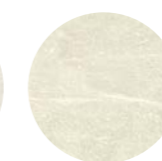

Ibla Resina

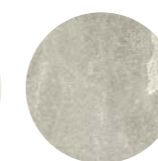

Ibla Nera



5

Formati
Sizes
Formate
Formats

60×120
24"×48"



30×120
12"×48"



60×60
24"×24"



10×60
4"×24"



10×53
4"×20"



3

Superfici
Surfaces
Oberflächen
Surfaces

Naturale

Lappato

Antislip

1

Strutture 3D
3D structures
Strukturen
Décorations en relief

Tombolo



i



Tecnologia - Technology - Technologie:
Synchro Digit Piemme®
Superficie con struttura digitale sincronizzata
Synchronized digital structured surface
Im synchronisierten Digitaldruckverfahren
hergestellte 3D-Oberfläche
Surface avec texture et finition par
impression numérique synchronisée

Gres fine porcellanato ad impasto colorato
Coloured-body fine porcelain stoneware
Feinsteinzeug aus farbiger Masse
Grès cérame fin à pâte colorée

Effetto Pietra
Stone Look
Natursteinoptik
Effet Pierre

Rivestimento
Wall Tiles
Wandfliesen
Revêtement

Pavimento
Floor Tiles
Bodenfliesen
Sol

Ripresa grafica tra le diverse lastre rettificata contenuta entro le tolleranze previste dalla norma. Per un corretto allineamento si consiglia di utilizzare una fuga di 2 mm.
Graphic representation between the rectified tiles is contained within the tolerances provided by the standard. For a correct alignment it is recommended to use a 2 mm joint.
Grafische Darstellung zwischen den verschiedenen rektifizierten Platten innerhalb der in der Norm vorgesehenen Toleranzen. Für eine korrekte Anpassung wird eine Fuge von 2mm empfohlen.
Reproduction graphique entre les différents carreaux rectifiés dans les limites des tolérances prévues par la norme. Pour un alignement correct, il est recommandé d'utiliser joints de 2 mm.

▶ WATCH THE VIDEO



Ibla Linfa

Per un risultato di posa ottimale si consiglia di prelevare le piastrelle da 5/6 scatole contemporaneamente.

For best installation results, we suggest taking the tiles from 5/6 boxes at the same time.



60x120
03976A | Ibla Linfa Nat/Ret
03980A | Ibla Linfa Lap/Ret



60x60
03984A | Ibla Linfa Nat/Ret
03988A | Ibla Linfa Lap/Ret



28,2x28,5
04007 | Opus Linfa Mix Lap/Nat

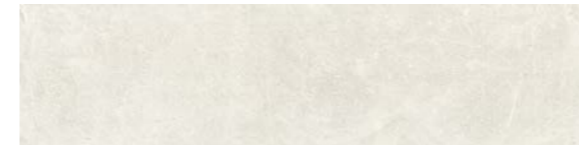

30x120
03992A | Ibla Linfa Nat/Ret
03996A | Ibla Linfa Lap/Ret



10x53
04016 | Chevron Linfa Nat/Ret
04021 | Chevron Linfa Lap/Ret



30x30
04012 | Ragusa Linfa Mix Lap/Nat



60x120
04004A | Ibla Zagara Light Nat/Ret



10x60
04025 | Listoncino Linfa Nat/Ret
04029 | Listoncino Linfa Lap/Ret



60x120
04002A | Ibla Tombolo Light Lap/Ret



Ibla Colofonia

Per un risultato di posa ottimale si consiglia di prelevare le piastrelle da 5/6 scatole contemporaneamente.

For best installation results, we suggest taking the tiles from 5/6 boxes at the same time.



60x120

03977A | Ibla Colofonia Nat/Ret
03981A | Ibla Colofonia Lap/Ret
05273 | Ibla Colofonia Antislip/Ret



60x60

03985A | Ibla Colofonia Nat/Ret
03989A | Ibla Colofonia Lap/Ret



28,2x28,5

04008 | Opus Colofonia Mix Lap/Nat



30x120

03993A | Ibla Colofonia Nat/Ret
03997A | Ibla Colofonia Lap/Ret

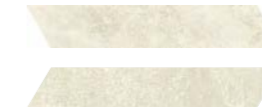

10x53

04017 | Chevron Colofonia Nat/Ret
04022 | Chevron Colofonia Lap/Ret



30x30

04013 | Ragusa Colofonia Mix Lap/Nat



10x60

04026 | Listoncino Colofonia Nat/Ret
04031 | Listoncino Colofonia Lap/Ret

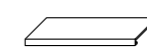
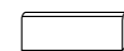



Ibla Resina

Per un risultato di posa ottimale si consiglia di prelevare le piastrelle da 5/6 scatole contemporaneamente.

For best installation results, we suggest taking the tiles from 5/6 boxes at the same time.



60x120

03978A | Ibla Resina Nat/Ret
03982A | Ibla Resina Lap/Ret
05274 | Ibla Resina Antislip/Ret



60x60

03986A | Ibla Resina Nat/Ret
03990A | Ibla Resina Lap/Ret



28,2x28,5

04009 | Opus Resina Mix Lap/Nat



30x120

03994A | Ibla Resina Nat/Ret
03998A | Ibla Resina Lap/Ret

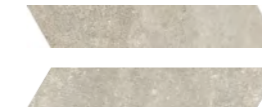

10x53

04018 | Chevron Resina Nat/Ret
04023 | Chevron Resina Lap/Ret



30x30

04014 | Ragusa Resina Mix Lap/Nat



60x120

04005A | Ibla Zagara Mid Nat/Ret



10x60

04027 | Listoncino Resina Nat/Ret
04032 | Listoncino Resina Lap/Ret

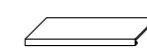
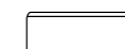



Ibla Nera

Per un risultato di posa ottimale si consiglia di prelevare le piastrelle da 5/6 scatole contemporaneamente.

For best installation results, we suggest taking the tiles from 5/6 boxes at the same time.



60x120

03975A | Ibla Nera Nat/Ret
03979A | Ibla Nera Lap/Ret



60x60

03983A | Ibla Nera Nat/Ret
03987A | Ibla Nera Lap/Ret



28,2x28,5

04006 | Opus Nera Mix Lap/Nat



30x120

03991A | Ibla Nera Nat/Ret
03995A | Ibla Nera Lap/Ret



10x53

04015 | Ibla Chevron Nera Nat/Ret
04019 | Ibla Chevron Nera Lap/Ret



30x30

04011 | Ragusa Nera Mix Lap/Nat



60x120

04003A | Ibla Zagara Dark Nat/Ret



10x60

04024 | Listoncino Nera Nat/Ret
04028 | Listoncino Nera Lap/Ret



60x120

04001A | Ibla Tombolo Dark Lap/Ret

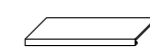
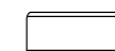

Formati Sizes	MM	Pezzi Scatola Pieces/Box Stck/Karton Carreaux/Boîte	Mq/Scatola Sqmt/Box Qm/Karton M2/Boîte	Kg/Scatola Kgs/Box Kg/Karton Kg/Boîte	Scatole/Paletta Boxes/Pallet Karton/Palette Boîte/Palette	Mq/Paletta Sqmt/Pallet Qm/Pallet M2/Palette	Kg/Paletta Kgs/Pallet Kg/Pallet Kg/Palette	Formato Paletta Size Pallet Format Pallet Dim. Palette	
60x120 (24"x48") Nat/Ret - Lap/Ret	P	9,5	2	1,44	31,00	30	43,20	930	122x82x75
30x120 (12"x48") Nat/Ret - Lap/Ret	P	9,5	4	1,44	31,00	36	51,84	1116	122x96x70
60x60 (24"x24") Nat/Ret - Lap/Ret	P	9,5	4	1,44	29,00	32	46,08	928	120x80x75
60x120 (24"x48") Tombolo Lap/Ret	P	9,5	2	1,44	31,00	30	43,20	930	122x82x75
60x120 (24"x48") Zagara Nat/Ret	P	9,5	2	1,44	31,00	30	43,20	930	122x82x75
10x60 (4"x24") Listoncino Nat/Ret - Lap/Ret	P	9,5	10	0,60	12,50	72	43,20	900	120x80x75
10x53 (4"x20") Chevron Nat/Ret - Lap/Ret	P	9,5	12	0,636	13,20	60	38,16	792	120x80x75
28,2x28,5 (11"x11¼") Opus Mix Lap/Nat	P	9,5	6	0,482	9,5	60	-	-	-
30x30 (12"x12") Ragusa Mix Lap/Nat	P	9,5	5	0,45	8,5	60	-	-	-
Pezzi Speciali / Special Pieces									
33x120 (13"x48") Gradino Costa Retta Nat/Ret - Lap/Ret	P	9,5	2	0,792	18,50	20	-	-	-
4,5x60 (1½"x24") Battiscopa Nat/Ret - Lap/Ret	P	9,5	14	0,378	8,00	80	-	-	-

CLICK

PDF Merchandising



	Formati Sizes	60x120 24"x48"	30x120 12"x48"	60x60 24"x24"	Listoncino 10x60 4"x24"	Chevron 10x53 4"x20"	DIN 51130	DIN 51097	DCOF	BS EN 7976-2
Ibla Linfa	Nat/Ret	03976A	03992A	03984A	04025	04016	R10	A+B	>0.42	wet, dry >36
	Lap/Ret	03980A	03996A	03988A	04029	04021	V3 R9	A	>0.42	
	Lap/Nat									
Ibla Colofonia	Nat/Ret	03977A	03993A	03985A	04026	04017	R10	A+B	>0.42	wet, dry >36
	Lap/Ret	03981A	03997A	03989A	04031	04022	V3 R9	A	>0.42	
	Antislip/Ret	05273					R11	A+B+C	>0.42	wet, dry >36
Ibla Resina	Nat/Ret	03978A	03994A	03986A	04027	04018	R10	A+B	>0.42	wet, dry >36
	Lap/Ret	03982A	03998A	03990A	04032	04023	V3 R9	A	>0.42	
	Antislip/Ret	05274					R11	A+B+C	>0.42	wet, dry >36
Ibla Nera	Nat/Ret	03975A	03991A	03983A	04024	04015	R10	A+B	>0.42	wet, dry >36
	Lap/Ret	03979A	03995A	03987A	04028	04019	V3 R9	A	>0.42	
	Lap/Nat									

	Zagara 60x120 24"x48"	Tombolo 60x120 24"x48"	Opus Mix 28,2x28,5 11"x11¼"	Ragusa Mix 30x30 12"x12"	Gradino Costa Retta 33x120 13"x48"	Battiscopa 4,5x60 1½"x24"
	04004A	04002A	04007	04012	04043A	04034
					04047A	04038
					04044A	04035
					04048A	04039
			04008	04013		
	04005A				04045A	04036
					04049A	04041
			04009	04014		
	04003A				04042A	04033
		04001A			04046A	04037
			04006	04011		



Evoluta

Nasce con Evoluta Synchro Digit Piemme™: la Superficie con Struttura Digitale Sincronizzata Piemme capace di esprimersi in varianti illimitate che innalzano lo standard qualitativo dell'intero settore ceramico. La superficie tridimensionale non è più formata per pressatura ed è quindi libera dai vincoli ripetitivi dei classici stampi per ceramica; inoltre è perfettamente sincronizzata con l'andamento della grafica di superficie.

Evoluta marks the launch of Synchro Digit Piemme™: the Piemme synchronized digital structure surface capable of expressing itself in unlimited variants that raise the quality standard of the entire ceramic industry. The three-dimensional surface is no longer formed by pressing and is therefore not limited by the repetitive constraints of classic ceramic moulds; it is also perfectly synchronized with the surface graphic pattern.

In Evoluta zeigt sich zum ersten Mal Synchro Digit Piemme™, die mit synchronisierter digitaler Struktur Oberfläche Piemme, die durch die Eröffnung unbegrenzter Gestaltungsvarianten den Qualitätsstandard der gesamten Keramikbranche anhebt. Die reliefierte Oberfläche wird nicht mehr durch Pressung erzielt und ist deshalb auch nicht an die Wiederholungsmuster der klassischen Formpressen für Keramik gebunden. Sie ist auch mit den Oberflächengrafiken vollkommen synchronisiert.

Evoluta marque la naissance de Synchro Digit Piemme™, la surface avec structure synchronisée numérique Piemme, dont les variantes illimitées permettent une expression qui vient rehausser les normes de qualité de tout le secteur de la céramique. La surface tridimensionnelle n'étant plus formée par pressage, elle est désormais libérée des contraintes répétitives imposées par les moules pour céramique classiques. Par ailleurs, elle est parfaitement synchronisée avec l'évolution des éléments graphiques de la surface.

5

Colori
Colours
Farben
Couleurs

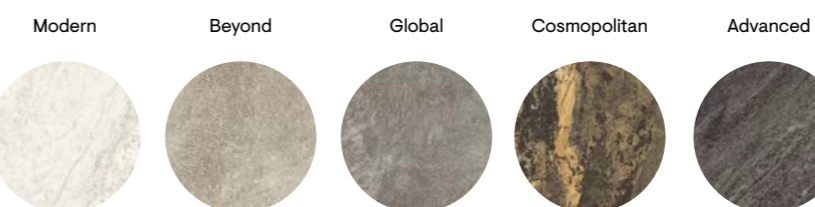

3

Formati
Sizes
Formate
Formats

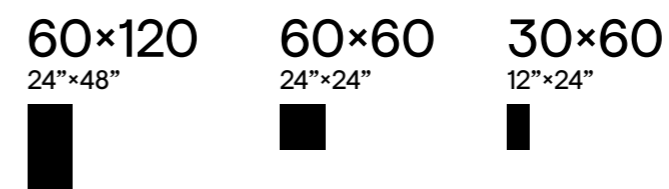

3

Superfici
Surfaces
Oberflächen
Surfaces

Naturale Lappato Grip

3

Strutture 3D
3D structures
Strukturen
Décorations en relief



i



Tecnologia - Technology - Technologie:
Synchro Digit Piemme™
Superficie con struttura digitale sincronizzata
Synchronized digital structured surface
Im synchronisierten Digitaldruckverfahren
hergestellte 3D-Oberfläche
Surface avec texture et finition par
impression numérique synchronisée

Gres fine porcellanato ad impasto colorato
Coloured-body fine porcelain stoneware
Feinsteinzeug aus farbiger Masse
Grès cérame fin à pâte colorée

Effetto Pietra
Stone Look
Natursteinoptik
Effet Pierre

Rivestimento
Wall Tiles
Wandfliesen
Revêtement

Pavimento
Floor Tiles
Bodenfliesen
Sol

Ripresa grafica tra le diverse lastre rettificata contenuta entro le tolleranze previste dalla norma. Per un corretto allineamento si consiglia di utilizzare una fuga di 2 mm.
Graphic representation between the rectified tiles is contained within the tolerances provided by the standard. For a correct alignment it is recommended to use a 2 mm joint.
Grafische Darstellung zwischen den verschiedenen rektifizierten Platten innerhalb der in der Norm vorgesehenen Toleranzen. Für eine korrekte Anpassung wird eine Fuge von 2mm empfohlen.
Reproduction graphique entre les différents carreaux rectifiés dans les limites des tolérances prévues par la norme. Pour un alignement correct, il est recommandé d'utiliser joints de 2 mm.

▶ WATCH THE VIDEO



Modern

Per un risultato di posa ottimale si consiglia di prelevare le piastrelle da 5/6 scatole contemporaneamente.

For best installation results, we suggest taking the tiles from 5/6 boxes at the same time.



60x120

03544A | Evoluta Modern Nat/Ret
03548A | Evoluta Modern Lap/Ret
03552A | Evoluta Modern Grip/Ret



60x60

03536A | Evoluta Modern Nat/Ret
03540A | Evoluta Modern Lap/Ret



30x60

03528A | Evoluta Modern Nat/Ret
03532A | Evoluta Modern Lap/Ret



60x120

03614A | Evoluta Cluster Light Nat/Ret



30x60

03609A | Evoluta Cave Light Nat/Ret



60x120

03685A | Evoluta Forest Light Lap/Ret

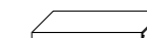
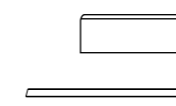



Beyond

Per un risultato di posa ottimale si consiglia di prelevare le piastrelle da 5/6 scatole contemporaneamente.

For best installation results, we suggest taking the tiles from 5/6 boxes at the same time.



60x120

03596A | Evoluta Beyond Nat/Ret
03597A | Evoluta Beyond Lap/Ret
03598A | Evoluta Beyond Grip/Ret



60x60

03594A | Evoluta Beyond Nat/Ret
03595A | Evoluta Beyond Lap/Ret



30x60

03592A | Evoluta Beyond Nat/Ret
03593A | Evoluta Beyond Lap/Ret



60x120

03614A | Evoluta Cluster Light Nat/Ret



30x60

03609A | Evoluta Cave Light Nat/Ret



60x120

03685A | Evoluta Forest Light Lap/Ret



Global

Per un risultato di posa ottimale si consiglia di prelevare le piastrelle da 5/6 scatole contemporaneamente.

For best installation results, we suggest taking the tiles from 5/6 boxes at the same time.



60x120

03545A | Evoluta Global Nat/Ret
03549A | Evoluta Global Lap/Ret
03553A | Evoluta Global Grip/Ret



60x60

03537A | Evoluta Global Nat/Ret
03541A | Evoluta Global Lap/Ret



30x60

03529A | Evoluta Global Nat/Ret
03533A | Evoluta Global Lap/Ret

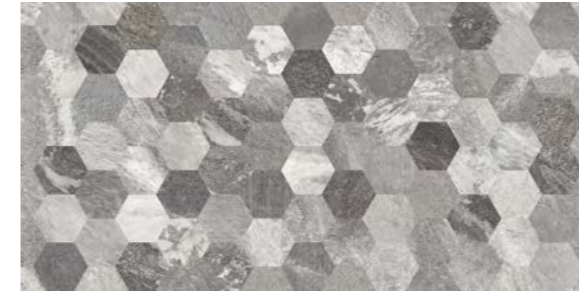

60x120

03613A | Evoluta Cluster Dark Nat/Ret

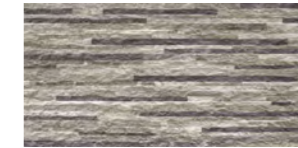

30x60

03608A | Evoluta Cave Dark Nat/Ret



60x120

03612A | Evoluta Forest Lap/Ret



Cosmopolitan

Per un risultato di posa ottimale si consiglia di prelevare le piastrelle da 5/6 scatole contemporaneamente.

For best installation results, we suggest taking the tiles from 5/6 boxes at the same time.



60x120

03546A | Evoluta Cosmopolitan Nat/Ret
03550A | Evoluta Cosmopolitan Lap/Ret
03554A | Evoluta Cosmopolitan Grip/Ret

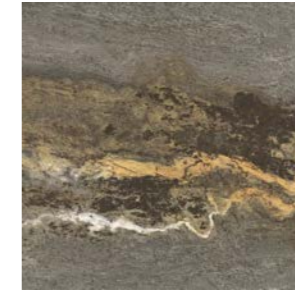

60x60

03538A | Evoluta Cosmopolitan Nat/Ret
03542A | Evoluta Cosmopolitan Lap/Ret



30x60

03530A | Evoluta Cosmopolitan Nat/Ret
03534A | Evoluta Cosmopolitan Lap/Ret



60x120

03615A | Evoluta Cluster Multicolor Nat/Ret



30x60

03611A | Evoluta Cave Multicolor Nat/Ret



60x120

03612A | Evoluta Forest Lap/Ret



Advanced

Per un risultato di posa ottimale si consiglia di prelevare le piastrelle da 5/6 scatole contemporaneamente.

For best installation results, we suggest taking the tiles from 5/6 boxes at the same time.



60x120

03543A | Evoluta Advanced Nat/Ret
03547A | Evoluta Advanced Lap/Ret
03551A | Evoluta Advanced Grip/Ret



60x60

03535A | Evoluta Advanced Nat/Ret
03539A | Evoluta Advanced Lap/Ret



30x60

03527A | Evoluta Advanced Nat/Ret
03531A | Evoluta Advanced Lap/Ret



60x120

03613A | Evoluta Cluster Dark Nat/Ret

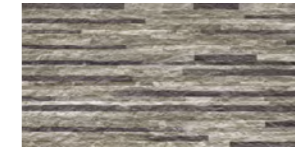

30x60

03608A | Evoluta Cave Dark Nat/Ret



60x120

03612A | Evoluta Forest Lap/Ret

Formato / Size		± MM	Pezzi Scatola Pieces/Box Stck/Karton Carreaux/Boîte	Mq/Scatola Sqmt/Box Qm/Karton M2/Boîte	Kg/Scatola Kgs/Box Kg/Karton Kg/Boîte	Scatole/Paletta Boxes/Pallet Karton/Palette Boîte/Palette	Mq/Paletta Sqmt/Pallet Qm/Pallet M2/Palette	Kg/Paletta Kgs/Pallet Kg/Pallet Kg/Palette	Formato Paletta Size Pallet Format Pallet Dim. Palette
60x120 (24"x48") Nat/Ret	P	9,5	2	1,44	31,00	30	43,20	930	122x82x75
60x120 (24"x48") Lap/Ret	P	9,5	2	1,44	31,00	30	43,20	930	122x82x75
60x120 (24"x48") Grip/Ret	P	9,5	2	1,44	31,00	30	43,20	930	122x82x75
60x60 (24"x24") Nat/Ret	P	9,5	4	1,44	29,00	32	46,08	928	120x80x75
60x60 (24"x24") Lap/Ret	P	9,5	4	1,44	30,00	32	46,08	960	120x80x75
30x60 (12"x24") Nat/Ret	P	9,5	7	1,26	25,30	40	50,40	1012	120x80x75
30x60 (12"x24") Lap/Ret	P	9,5	7	1,26	26,30	40	50,40	1052	120x80x75
60x120 (24"x48") Forest Lap/Ret	P	9,5	2	1,44	31,00	30	43,20	930	122x82x75
60x120 (24"x48") Cluster Nat/Ret	P	9,5	2	1,44	31,00	30	43,20	930	122x82x75
30x60 (12"x24") Cave Nat/Ret	P	9,5	7	1,26	25,30	32	40,32	809,6	120x80x75
Pezzi Speciali / Special Pieces									
33x120 (13"x48") Gradino Costa Retta Nat/Ret - Lap/Ret	P	9,5	2	0,792	18,50	20	-	-	-
4,5x60 (1 1/4"x24") Battiscopa Nat/Ret - Lap/Ret	P	9,5	14	0,378	8,00	80	-	-	-
1,5x120 (3/4"x48") Bacchetta Jolly Nat/Ret - Lap/Ret	P	9,5	6	0,108	2,50	48	-	-	-
1,5x1,5 (3/4"x3/4") Unghia Jolly Nat/Ret - Lap/Ret	P	9,5	6	0,001	0,50	48	-	-	-

CLICK

PDF Merchandising



	Formati Sizes	60x120 24"x48"	60x60 24"x24"	30x60 12"x24"				
		± 9,5	± 9,5	± 9,5	DIN 51130	DIN 51097	DCOF	BS EN 7976-2
	Nat/Ret	03544A	03536A	03528A	R10	A+B	>0,42	wet, dry >36
	Lap/Ret	03548A	03540A	03532A	V3		0,42	
	Grip/Ret	03552A			R11	A+B+C	>0,42	wet, dry >36
	Nat/Ret	03596A	03594A	03592A	R10	A+B	>0,42	wet, dry >36
	Lap/Ret	03597A	03595A	03593A	V3		0,42	
	Grip/Ret	03598A			R11	A+B+C	>0,42	wet, dry >36
	Nat/Ret	03545A	03537A	03529A	R10	A+B	>0,42	wet, dry >36
	Lap/Ret	03549A	03541A	03533A	V3		0,42	
	Grip/Ret	03553A			R11	A+B+C	>0,42	wet, dry >36
	Nat/Ret	03546A	03538A	03530A	R10	A+B	>0,42	wet, dry >36
	Lap/Ret	03550A	03542A	03534A	V4		0,42	
	Grip/Ret	03554A			R11	A+B+C	>0,42	wet, dry >36
	Nat/Ret	03543A	03535A	03527A	R10	A+B	>0,42	wet, dry >36
	Lap/Ret	03547A	03539A	03531A	V3		0,42	
	Grip/Ret	03551A			R11	A+B+C	>0,42	wet, dry >36

Strutture 3D 3D Structures				Pezzi Speciali Special Pieces			
Cluster 60x120 24"x48"	Forest Light 60x120 24"x48"	Forest 60x120 24"x48"	Cave 30x60 12"x24"	Gradino Costa Retta 33x120 13"x48"	Battiscopa 4,5x60 1 1/4"x24"	Bacchetta Jolly 1,5x120 3/4"x48"	Unghia Jolly 1,5x1,5 3/4"x3/4"
± 9,5	± 9,5	± 9,5	± 9,5	± 9,5	± 9,5	± 9,5	± 9,5
03614A			03609A	03564A	03556	03572A	03581
	03685A			03568A	03560	03576A	03585
03614A			03609A	03602A	03599	03604A	03606
	03685A			03603A	03601	03605A	03607
03613A			03608A	03565A	03557	03573A	03582
	03612A			03569A	03561	03577A	03586
03615A			03611A	03566A	03558	03574A	03583
	03612A			03570A	03562	03578A	03587
03613A			03608A	03563A	03555	03571A	03579
	03612A			03567A	03559	03575A	03584

Uniquestone

Uniquestone: una collezione ispirata all'estetica di pietre, graniti e marmi differenti, sapientemente miscelati tra di loro, per muovere con carattere lo stile di ogni ambiente, residenziale o commerciale.

Uniquestone: a collection inspired by the aesthetics of different stones, granites and marbles, skilfully mixed together to move with character. The style of every environment, whether residential or commercial.

Uniquestone: eine am aussehen verschiedener und auf gelungene weise miteinander kombinierter steine, granite und marmorarten inspirierte kollektion. Bringt stilvoll bewegung und charakter in jeden gewerbe- oder wohnraum.

Uniquestone: une collection qui puise son inspiration a l'esthetique de la pierre. Plusieurs types de granits et de marbres savamment melanges apportent une note authentique de caractere a tout espace de vic, a usage privatif ou commercial.

5

Colori
Colours
Farben
Couleurs

Silk



Sand

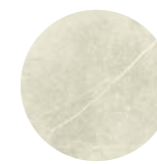

Silver

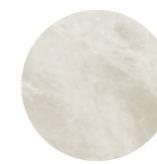

Titanium

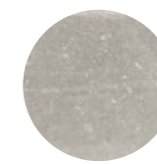

Nite



6

Formati
Sizes
Formate
Formats

120×120
48"×48"



60×120
24"×48"



80×80
31½"×31½"



60×60
24"×24"



30×60
12"×24"



10×53
4"×20"



3

Superfici
Surfaces
Oberflächen
Surfaces

Naturale

Levigato

Bocciardato

3

Strutture 3D
3D structures
Strukturen
Decorations and relief

Level



Maya



Weave



i

Effetto Pietra
Stone Look
Natursteinoptik
Effet Pierre

Rivestimento
Wall Tiles
Wandfliesen
Revêtement

Pavimento
Floor Tiles
Bodenfliesen
Sol

Gres fine porcellanato ad impasto colorato
Coloured-body fine porcelain stoneware
Feinsteinzeug aus farbiger Masse
Grès cérame fin à pâte colorée

Tecnologia digitale
Digital technology
Digital Technologie
Technologie numérique



WATCH THE VIDEO



Silk



120x120
05295 | Unique Silk Nat/Ret



80x80
03639 | Unique Silk Nat/Ret



60x60
01702A | Unique Silk Nat/Ret
01691A | Unique Silk Lev/Ret

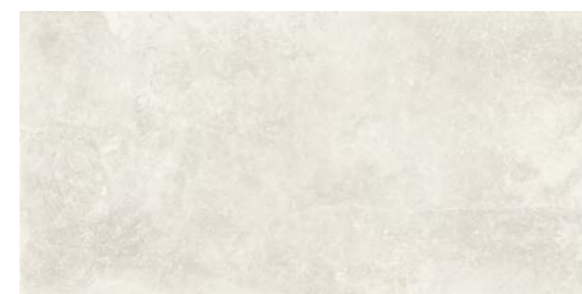

60x120
02995A | Unique Silk Nat/Ret
02999A | Unique Silk Lev/Ret
03003A | Unique Silk Bocciardato Ret



30x60
01707A | Unique Silk Nat/Ret
01696A | Unique Silk Lev/Ret

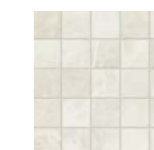

30x30
01771 | Unique Silk Mosaico Nat/Ret



30x30
01786 | Unique Silk Mix All In Ret



60x120
03008A | Unique Silk Level Ret



10x53
01792 | Unique Silk Chevron Nat/Ret

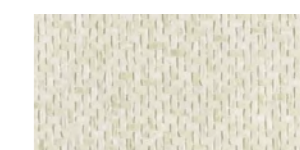

30x60
01918A | Unique Weave Sk/Sd Nat/Ret



30x60
01785A | Unique Nite Maya Design Ret



30x60
01781A | Unique Silk Maya Ret



Sand



120x120
05296 | Unique Sand Nat/Ret



80x80
03684 | Unique Sand Nat/Ret



60x60
01703A | Unique Sand Nat/Ret
01692A | Unique Sand Lev/Ret



60x120
02996A | Unique Sand Nat/Ret
03000A | Unique Sand Lev/Ret
03004A | Unique Sand Bocciardato Ret



30x60
01708A | Unique Sand Nat/Ret
01697A | Unique Sand Lev/Ret

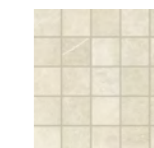

30x30
01772 | Unique Sand Mosaico Nat/Ret



30x30
01787 | Unique Sand Mix All In Ret



60x120
03009A | Unique Sand Level Ret



10x53
01793 | Unique Sand Chevron Nat/Ret



30x60
01785A | Unique Nite Maya Design Ret

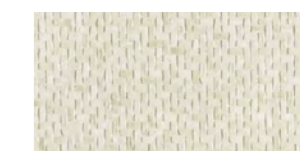

30x60
01918A | Unique Weave Sk/Sd Nat/Ret



30x60
01782A | Unique Sand Maya Ret



Silver



80x80
03642 | Unique Silver Nat/Ret



60x60
01704A | Unique Silver Nat/Ret
01693A | Unique Silver Lev/Ret



30x30
01773 | Unique Silver Mosaico Nat/Ret



60x120
02997A | Unique Silver Nat/Ret
03001A | Unique Silver Lev/Ret
03005A | Unique Silver Bocciardato Ret



30x60
01709A | Unique Silver Nat/Ret
01698A | Unique Silver Lev/Ret



30x30
01788 | Unique Silver Mix All In Ret



10x53
01794 | Unique Silver Chevron Nat/Ret



30x60
01917A | Unique Weave Tm/Sr Nat/Ret



60x120
03010A | Unique Silver Level Ret

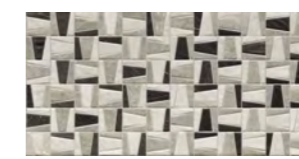

30x60
01785A | Unique Nite Maya Design Ret

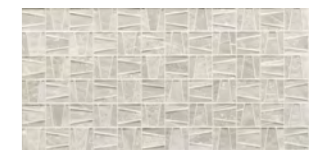

30x60
01783A | Unique Silver Maya Ret



Titanium



80x80
03637 | Unique Titanium Nat/Ret



60x60
01705A | Unique Titanium Nat/Ret
01694A | Unique Titanium Lev/Ret



30x30
01774 | Unique Titanium Mosaico Nat/Ret



60x120
02976A | Unique Titanium Nat/Ret
02977A | Unique Titanium Lev/Ret
03006A | Unique Titanium Bocciardato Ret



30x60
01711A | Unique Titanium Nat/Ret
01699A | Unique Titanium Lev/Ret



30x30
01789 | Unique Titanium Mix All In Ret

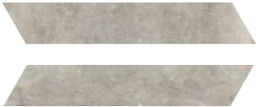

10x53
01795 | Unique Titanium Chevron Nat/Ret



30x60
01917A | Unique Weave Tm/Sr Nat/Ret



60x120
03011A | Unique Titanium Level Ret



30x60
01785A | Unique Nite Maya Design Ret



30x60
01784A | Unique Titanium Maya Ret



Nite



120x120
05297 | Unique Nite Nat/Ret



80x80
03617 | Unique Nite Nat/Ret



60x60
01706A | Unique Nite Nat/Ret
01695A | Unique Nite Lev/Ret



60x120
02998A | Unique Nite Nat/Ret
03002A | Unique Nite Lev/Ret
03007A | Unique Nite Bocciardato Ret



30x60
01712A | Unique Nite Nat/Ret
01701A | Unique Nite Lev/Ret



30x30
01775 | Unique Nite Mosaico Nat/Ret



60x120
03012A | Unique Nite Level Ret

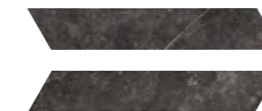

10x53
01796 | Unique Nite Chevron Nat/Ret









30x30
01791 | Unique Nite Mix All In Ret



30x60
01785A | Unique Nite Maya Design Ret







Imballi

Packing
Verpackung
Emballage

Formato / Size		± MM	 Pezzi Scatola Pcs/Box Stck/Karton Carreaux/Boîtes	 Mq/Scatola Sqmt/Box M2/Karton Qm/Boîtes	 Kg/Scatola Kgs/Box Kg/Karton Kg/Boîtes	 Scatola/Paletta Boxes/Pallet Karton/Palette Boîtes/Pallet	 Mq/Paletta Sqmt/Pallet M2/Palette Qm /Pallet	 Kg/Paletta Kgs/Pallet Kg/Palette Kg/Pallet	 Formato Paletta Size Pallet Format Palette Dim. Palette
120x120 (48"x48") Nat/Ret	P	9,5	2	2,88	58,00	22	63,36	1276	135x122x68
60x120 (24"x48") Nat/Ret	P	9,5	2	1,44	31,00	30	43,20	930	122x82x75
60x120 (24"x48") Lev/Ret	P	9,5	2	1,44	32,00	30	43,20	960	122x82x75
60x120 (24"x48") Bocciardato Ret - Level Ret	P	9,5	2	1,44	31,00	30	43,20	930	122x82x75
80x80 (31½"x31½") Nat/Ret	P	9,5	2	1,280	27,50	50	64,00	1375	122x80x96
60x60 (24"x24") Nat/Ret	P	9,5	4	1,44	29,00	32	46,08	928	120x80x75
60x60 (24"x24") Lev/Ret	P	9,5	4	1,44	30,00	32	46,08	960	120x80x75
30x60 (12"x24") Nat/Ret	P	9,5	7	1,26	25,30	40	50,40	1012	120x80x75
30x60 (12"x24") Lev/Ret	P	9,5	7	1,26	26,30	40	50,40	1052	120x80x75
30x60 (12"x24") Maya Ret	P	9,5	7	1,26	25,30	32	40,32	809,6	120x80x75
30x60 (12"x24") Weave Nat/Ret	P	9,5	7	1,26	25,30	32	40,32	809,6	120x80x75
10x53 (4"x20") Chevron Nat/Ret	P	9,5	12	0,636	13,20	60	38,16	792	120x80x75
30x30 (12"x12") Mosaico Nat/Ret	P	9,5	5	0,450	8,50	60	-	-	-
30x30 (12"x12") Mosaico All In Ret	P	9,5	6	0,540	10,20	54	-	-	-

Imballi

Packing
Verpackung
Emballage

Formato / Size		± MM	 Pezzi Scatola Pcs/Box Stck/Karton Carreaux/Boîtes	 Mq/Scatola Sqmt/Box M2/Karton Qm/Boîtes	 Kg/Scatola Kgs/Box Kg/Karton Kg/Boîtes	 Scatola/Paletta Boxes/Pallet Karton/Palette Boîtes/Pallet	 Mq/Paletta Sqmt/Pallet M2/Palette Qm /Pallet	 Kg/Paletta Kgs/Pallet Kg/Palette Kg/Pallet	 Formato Paletta Size Pallet Format Palette Dim. Palette
Pezzi Speciali / Special Pieces									
33x120 (13"x48") Gradino costa retta Nat/Ret	P	9,5	2	0,792	18,50	20	-	-	-
8x60 (3¼"x24") Battiscopa Nat/Ret	P	9,5	10	0,480	11,00	72	-	-	-
8x60 (3¼"x24") Battiscopa Lev/Ret	P	9,5	10	0,480	11,00	72	-	-	-
8x80 (3¼"x31½") Battiscopa Nat/Ret	P	9,5	7	0,450	11,00	65	-	-	-
6,5x120 (2½"x48") Battiscopa Nat/Ret - Lev/Ret	P	9,5	8	0,624	14,00	48	-	-	-

Riepilogo Gamma

Collection
Serie
Gamme

	Formati Sizes										Strutture 3D 3D Structures			
		120x120 48"x48"	60x120 24"x48"	80x80 31½"x31½"	60x60 24"x24"	30x60 12"x24"		Chevron 10x53 4"x20"	DIN 51130	DIN 51097	DCOF	Level 60x120 24"x48"	Maya 30x60 12"x24"	Weave 30x60 12"x24"
		± 9,5	± 9,5	± 9,5	± 9,5	± 9,5		± 9,5				± 9,5	± 9,5	± 9,5
	Nat/Ret	05295	02995A	03639	01702A	01707A	01792	R10	A+B	>0.42	03008A	01781A	01918A	
	Lev/Ret		02999A		01691A	01696A		V3						
	Bocciardato		03003A					R11	A+B+C	>0.42				
	Nat/Ret	05296	02996A	03684	01703A	01708A	01793	R10	A+B	>0.42	03009A	01782A	01918A	
	Lev/Ret		03000A		01692A	01697A		V3						
	Bocciardato		03004A					R11	A+B+C	>0.42				
	Nat/Ret		02997A	03642	01704A	01709A	01794	R10	A+B	>0.42	03010A	01783A	01917A	
	Lev/Ret		03001A		01693A	01698A		V3						
	Bocciardato		03005A					R11	A+B+C	>0.42				
	Nat/Ret		02976A	03637	01705A	01711A	01795	R10	A+B	>0.42	03011A	01784A	01917A	
	Lev/Ret		02977A		01694A	01699A		V3						
	Bocciardato		03006A					R11	A+B+C	>0.42				
	Nat/Ret	05297	02998A	03617	01706A	01712A	01796	R10	A+B	>0.42	03012A	01785A		
	Lev/Ret		03002A		01695A	01701A		V3						
	Bocciardato		03007A					R11	A+B+C	>0.42				

Riepilogo Gamma

Collection
Serie
Gamme

	Formati Sizes			Pezzi Speciali Special Pieces			
		Mosaico 30x30 12"x12"	Mosaico Mix All In 30x30 12"x12"	Gradino Costa Retta 33x120 13"x48"	Battiscopa 6,5x120 2½"x48"	Battiscopa 8x80 3¼"x31½"	Battiscopa 8x60 3¼"x24"
		± 9,5	± 9,5	± 9,5	± 9,5	± 9,5	± 9,5
	Nat/Ret	01771		03733A	01797	01808	01819
	Lev/Ret		01786		01803		01825
	Nat/Ret	01772		03734A	01798	01809	01821
	Lev/Ret		01787		01804		01826
	Nat/Ret	01773		03735A	01799	01811	01822
	Lev/Ret		01788		01805		01827
	Nat/Ret	01774		03736A	01801	01812	01823
	Lev/Ret		01789		01806		01828
	Nat/Ret	01775		03737A	01802	01813	01824
	Lev/Ret		01791		01807		01829

Bits&Pieces

Designed by Gordon Guillaumier

L'arte del decoro della Roma Antica, dell'"opus incertum e del lapis porphyrites", sono reinterpretati secondo le tecnologie contemporanee, mantenendo intatto il fascino del riuso esaltato nella serialità dell'industria.

The art of decoration of ancient Rome, of the "opus incertum and lapis porphyrites", are reinterpreted according to contemporary technologies, maintaining intact the charm of reuse exalted in industrial mass production.

Die Verzierungskunst des Alten Roms, des "Opus incertum und Lapis porphyrites", den zeitgenössischen Technologien entsprechend neu interpretiert, unter Beibehaltung der Magie einer überschwänglichen Wiederverwendung in der Serienmäßigkeit der Industrie.

L'art de la décoration de la Rome antique, de l'"opus incertum et du lapis porphyrites", a été réinterprété selon les technologies modernes, en préservant le charme du recyclage dans la sérialité de l'industrie.

5

Colori
Colours
Farben
Couleurs

Powder Bone

Pearl Gray

Pewter Smoke

Peat Brown

Pitch Black

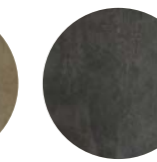
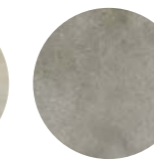

3

Formati
Sizes
Formate
Formats

120×120
48"×48"

60×60
24"×24"

30×60
12"×24"



3

Superfici
Surfaces
Oberflächen
Surfaces

Naturale

Levigato

Antislip

1

Strutture 3D
3D structures
Strukturen
Decorations and relief

Muretto

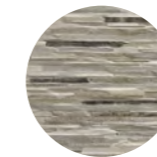

i

Effetto Pietra
Stone Look
Natursteinoptik
Effet Pierre

Rivestimento
Wall Tiles
Wandfliesen
Revêtement

Pavimento
Floor Tiles
Bodenfliesen
Sol

Gres fine porcellanato ad impasto colorato
Coloured-body fine porcelain stoneware
Feinsteinzeug aus farbiger Masse
Grès cérame fin à pâte colorée

Tecnologia digitale
Digital technology
Digital Technologie
Technologie numérique

▶ WATCH THE VIDEO



Powder Bone



120x120
03403A | Powder Bone Nat/Ret



60x60
01157A | Powder Bone Nat/Ret
01171A | Powder Bone Lev/Ret

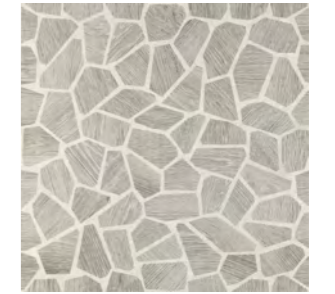

60x60
01162A | Powder Bone Facet Nat/Ret

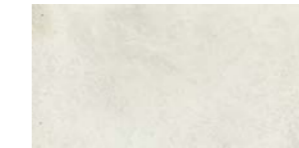

30x60
01205A | Powder Bone Nat/Ret
01222A | Powder Bone Antislip Ret



30x60
01210A | Powder Bone Facet Nat/Ret



30x60
01274A | Bits Muretto Cold Ret



30x30
01276 | Powder Bone Mosaico Nat/Ret

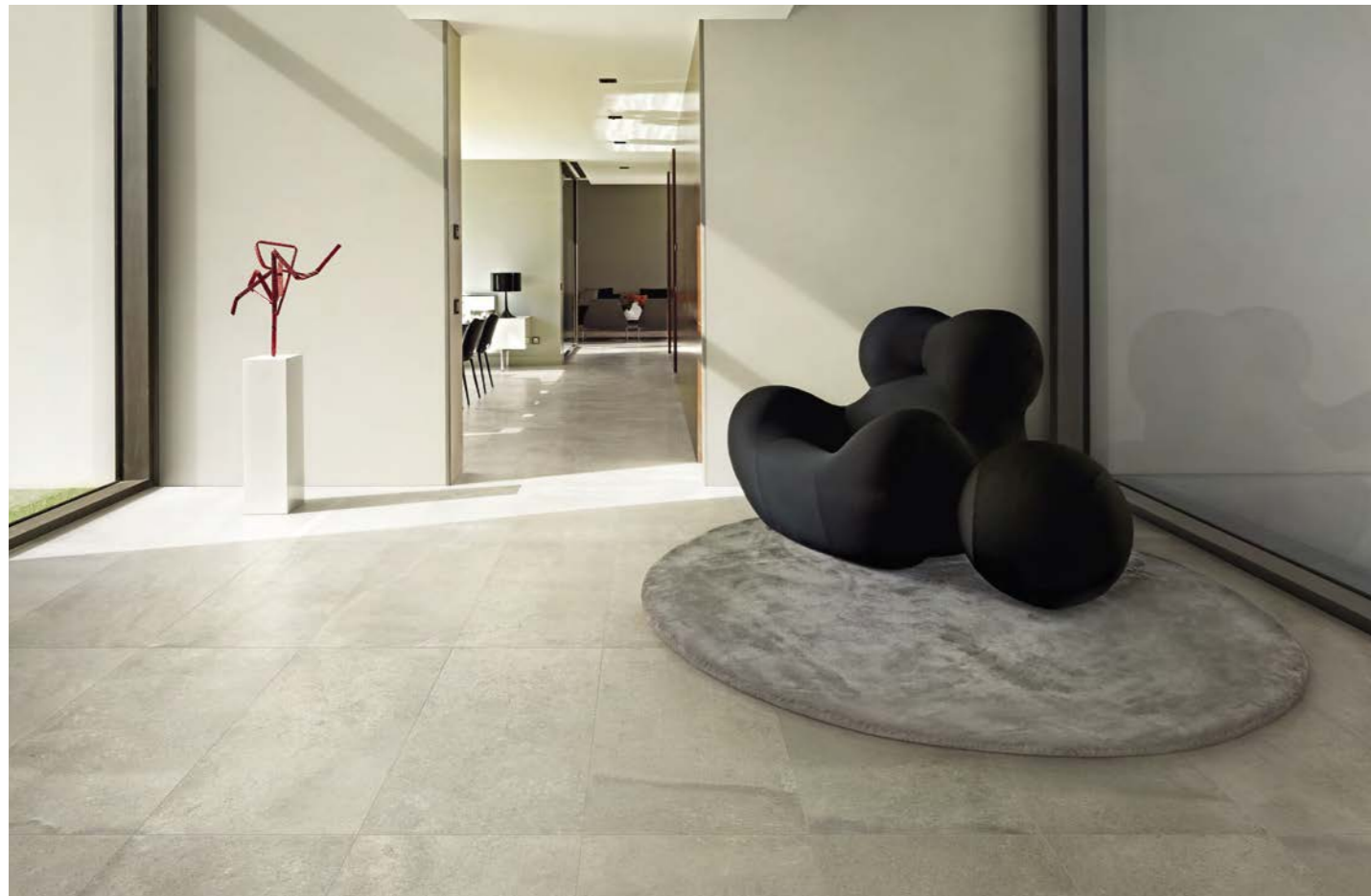

Pearl Gray



120x120
03404A | Pearl Gray Nat/Ret



60x60
01159A | Pearl Gray Nat/Ret
01173A | Pearl Gray Lev/Ret



60x60
01164A | Pearl Gray Quad Nat/Ret



30x60
01207A | Pearl Gray Nat/Ret
01224A | Pearl Gray Antislip Ret

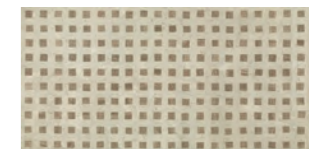

30x60
01212A | Pearl Gray Quad Nat/Ret

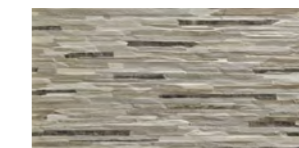

30x60
01274A | Bits Muretto Cold Ret



30x30
01278 | Pearl Gray Mosaico Nat/Ret



Peat Brown



60x60
01160A | Peat Brown Nat/Ret
01174A | Peat Brown Lev/Ret

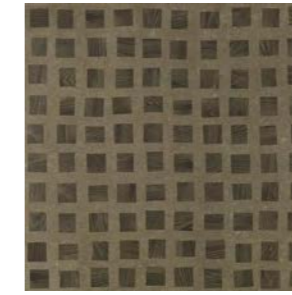

60x60
01165A | Peat Brown Quad Nat/Ret



30x60
01275A | Muretto Warm Ret



30x60
01208A | Peat Brown Nat/Ret
01225A | Peat Brown Antislip Ret

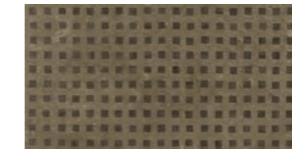

30x60
01213A | Peat Brown Quad Nat/Ret



30x30
01279 | Peat Brown Mosaico Nat/Ret



Pitch Black



60x60
01161A | Pitch Black Nat/Ret
01175A | Pitch Black Lev/Ret

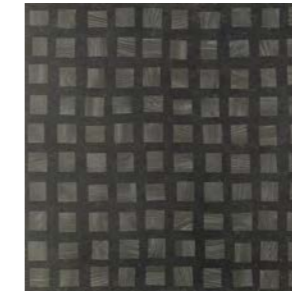

60x60
01166A | Pitch Black Quad Nat/Ret

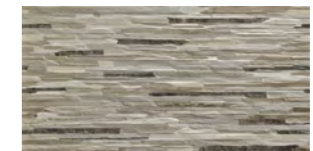

30x60
01274A | Bits Muretto Cold Ret

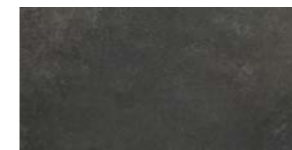

30x60
01209A | Pitch Black Nat/Ret
01226A | Pitch Black Antislip Ret

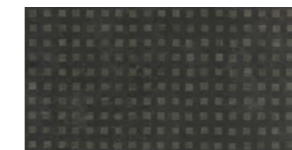

30x60
01214A | Pitch Black Quad Nat/Ret

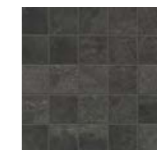

30x30
01281 | Pitch Black Mosaico Nat/Ret

Pewter Smoke



120x120
03405A | Pewter Smoke Nat/Ret



60x60
01158A | Pewter Smoke Nat/Ret
01172A | Pewter Smoke Lev/Ret



30x60
01206A | Pewter Smoke Nat/Ret
01223A | Pewter Smoke Antislip Ret

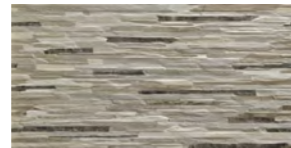

30x60
01274A | Bits Muretto Cold Ret



60x60
01163A | Pewter Smoke Facet Nat/Ret

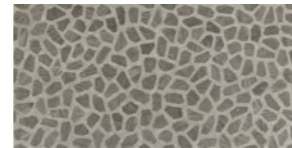

30x60
01211A | Pewter Smoke Facet Nat/Ret

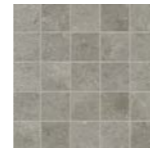

30x30
01277 | Pewter Smoke Mosaico Nat/Ret



Imballi

Packing
Verpackung
Emballage

Formato / Size		MM	Pezzi/Scatola Pieces/Box Stck/Karton Carreaux/Boîte	Mq/Scatola Sqmt/Box Qm/Karton M2/Boîte	Kg/Scatola Kgs/Box Kg/Karton Kg/Boîte	Scatole/Paletta Boxes/Pallet Karton/Pallet Boîte/Palette	Mq/Paletta Sqmt/Pallet Qm/Pallet M2 /Palette	Kg/Paletta Kgs/Pallet Kg/Pallet Kg/Palette	Formato Paletta Size Pallet Format Pallet Dim. Palette
120x120 Nat/Ret	P	9,5	2	2,88	58	22	63,36	1276	135x122x68
60x60 Nat/Ret	P	9,5	4	1,44	29	32	46,08	928	120x80x75
60x60 Lev/Ret	P	9,5	4	1,44	30	32	46,08	960	120x80x75
30x60 Nat/Ret	P	9,5	7	1,26	25,30	40	50,40	1012	120x80x75
30x60 Antislip/Ret	P	9,5	7	1,26	25,30	40	50,40	1012	120x80x75
30x60 Muretto	P	9,5	7	1,26	25,30	32	40,32	809,6	120x80x75
60x60 Quad Nat/Ret	P	9,5	4	1,44	29	32	46,08	928	120x80x75
60x60 Facet Nat/Ret	P	9,5	4	1,44	29	32	46,08	928	120x80x75
30x60 Quad Nat/Ret	P	9,5	7	1,26	25,30	40	50,40	1012	120x80x75
30x60 Facet Nat/Ret	P	9,5	7	1,26	25,30	40	50,40	1012	120x80x75
30x30 Mosaico (Su Rete)	P	9,5	5	0,45	8,5	60			
Pezzi Speciali / Special Pieces									
6,5x120 Battiscopa	P	9,5	8	0,624	14	48			
8x60 Battiscopa	P	9,5	10	0,48	11	72			
30x60 Step	P	9,5	6	1,08	22	36			















Riepilogo Gamma

Collection
Serie
Gamme

	Formati Sizes				UPEC	DIN 51130	DIN 51097	DCOF
		120x120 48"x48"	60x60 24"x24"	30x60 12"x24"				
 Powder Bone	Nat/Ret	03403A	01157A	01205A	V2	R10	A+B	> 0,42
	Lev/Ret		01171A					
	Antislip			01222A		R11		> 0,42
 Pearl Gray	Nat/Ret	03404A	01159A	01207A	V2	R10	A+B	> 0,42
	Lev/Ret		01173A					
	Antislip			01224A		R11		> 0,42
 Pewter Smoke	Nat/Ret	03405A	01158A	01206A	V2	R10	A+B	> 0,42
	Lev/Ret		01172A					
	Antislip			01223A		R11		> 0,42
 Peat Brown	Nat/Ret		01160A	01208A	V2	R10	A+B	> 0,42
	Lev/Ret		01174A					
	Antislip			01225A		R11		> 0,42
 Pitch Black	Nat/Ret		01161A	01209A	V2	R10	A+B	> 0,42
	Lev/Ret		01175A					
	Antislip			01226A		R11		> 0,42

Riepilogo Gamma

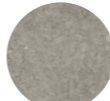
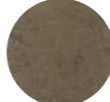
Collection
Serie
Gamme

	Formati Sizes	Strutture 3D 3D Structures		 Mosaico 30x30 (Su Rete) 12"x12" (2"x2" Dot)	 Quad 60x60 24"x24"	 Quad 30x60 12"x24"	 Facet 60x60 24"x24"	 Facet 30x60 12"x24"	Pezzi Speciali Special Pieces		
		 Muretto Cold 30x60 12"x24"	 Muretto Warm 30x60 12"x24"						 Battiscopa 6,5x120 2 1/2"x48"	 Battiscopa 8x60 3 1/4"x24"	 Step 30x60 12"x24"
 Powder Bone	Nat/Ret	01274A	01275A	01276			01162A	01210A	01401	01248	01259
										01254	
 Pearl Gray	Nat/Ret	01274A		01278	01164A	01212A			01402	01251	01262
										01256	
 Pewter Smoke	Nat/Ret	01274A		01277			01163A	01211A	01403	01249	01261
										01255	
 Peat Brown	Nat/Ret		01275A	01279	01165A	01213A				01252	01263
										01257	
 Pitch Black	Nat/Ret	01274A		01281	01166A	01214A				01253	01264
										01258	

Geostone

Da un'attenta ricerca di design nasce Geostone. Il fascino senza tempo delle rocce sedimentarie è riproposto in un blend armonizzato sulla superficie del grès porcellanato Piemme.

Geostone was created on the basis of careful research into design. The timeless appeal of sedimentary rocks is re-presented in a harmonized blend on the surfaces of Piemme porcelain stoneware.

Aus einer sorgfältigen Designstudie entsteht Geostone. Zeitlose Magie des Sedimentgesteins, an der Oberfläche des Feinsteinzeugs von Piemme mit harmonisch abgestimmtem Blend nachempfunden.

Geostone est issue d'une recherche de design attentive; la fascination intemporelle des roches sédimentaires a été revisitée en un mélange harmonieux sur la surface du grès cérame Piemme.

5

Colori
Colours
Farben
Couleurs



5

Formati
Sizes
Formate
Formats

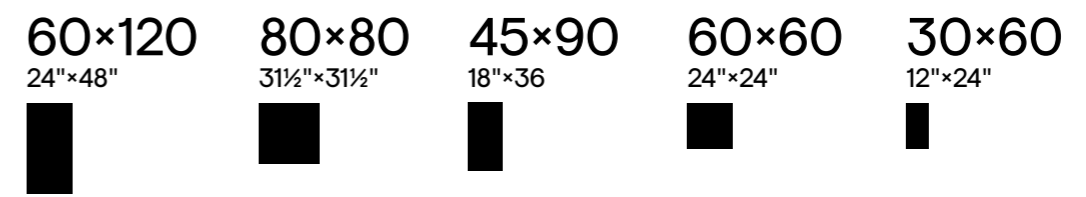

3

Superfici
Surfaces
Oberflächen
Surfaces

Naturale Levigato Velvet

2

Strutture 3D
3D structures
Strukturen
Decorations and relief



i

Effetto Pietra
Stone Look
Natursteinoptik
Effet Pierre

Rivestimento
Wall Tiles
Wandfliesen
Revêtement

Pavimento
Floor Tiles
Bodenfliesen
Sol

Gres fine porcellanato ad impasto colorato
Coloured-body fine porcelain stoneware
Feinsteinzeug aus farbiger Masse
Grès cérame fin à pâte colorée

Tecnologia digitale
Digital technology
Digital Technologie
Technologie numérique



Bianco



60x120
03053A | Geostone Bianco Nat/Ret
03057A | Geostone Bianco Lev/Ret



80x80
03841 | Geostone Bianco Nat/Ret



60x60
62150A | Geostone Bianco Nat/Ret
62200A | Geostone Bianco Lev/Ret

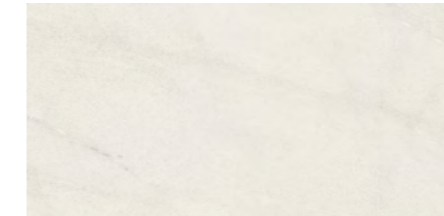

45x90
03708 | Geostone Bianco Nat/Ret



30x60
62750A | Geostone Bianco Nat/Ret



30x60
63550A | Geo Velvet Bianco Grip/Ret

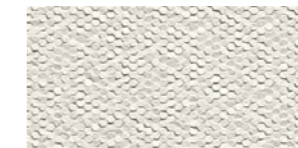

30x60
63600A | Geo Esagonetta Bianco Nat/Ret



30x30
63650 | Geo Mosaico Bianco Nat/Ret

Beige



60x120
03054A | Geostone Beige Nat/Ret
03058A | Geostone Beige Lev/Ret



80x80
03843 | Geostone Beige Nat/Ret



60x60
62170A | Geostone Beige Nat/Ret
62220A | Geostone Beige Lev/Ret

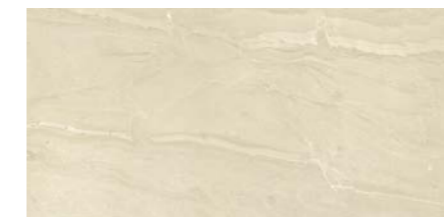

45x90
03883 | Geostone Beige Nat/Ret



30x60
62780A | Geostone Beige Nat/Ret

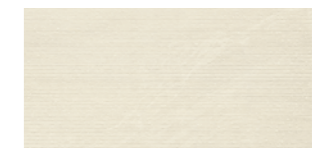

30x60
63570A | Geo Velvet Beige Grip/Ret



30x60
63620A | Geo Esagonetta Beige Nat/Ret

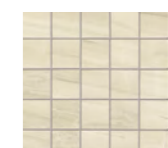

30x30
64860 | Geo Mosaico Beige Nat/Ret

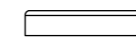



Tortora



60x120

03056A | Geostone Tortora Nat/Ret
03061A | Geostone Tortora Lev/Ret



80x80

03842 | Geostone Tortora Nat/Ret



60x60

62190A | Geostone Tortora Nat/Ret
62240A | Geostone Tortora Lev/Ret



45x90

03485 | Geostone Tortora Nat/Ret



30x60

62840A | Geostone Tortora Nat/Ret



30x60

63590A | Geo Velvet Tortora Grip/Ret



30x60

63640A | Geo Esagonetta Tortora Nat/Ret



30x30

65680 | Geo Mosaico Tortora Nat/Ret



Terra



45x90

03884 | Geostone Terra Nat/Ret



80x80

03844 | Geostone Terra Nat/Ret



60x60

62180A | Geostone Terra Nat/Ret
62230A | Geostone Terra Lev/Ret



30x60

62810A | Geostone Terra Nat/Ret

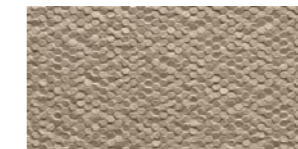

30x60

63630A | Geo Esagonetta Terra Nat/Ret



30x60

63580A | Geo Velvet Terra Grip/Ret

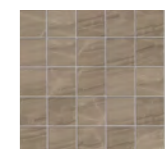

30x30

64870 | Geo Mosaico Terra Nat/Ret

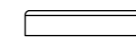

Grigio



60x120

03055A | Geostone Grigio Nat/Ret
03059A | Geostone Grigio Lev/Ret



45x90

03711 | Geostone Grigio Nat/Ret



80x80

03718 | Geostone Grigio Nat/Ret



30x60

62770A | Geostone Grigio Nat/Ret



30x60

63610A | Geo Esagonetta Grigio Nat/Ret



60x60

62160A | Geostone Grigio Nat/Ret
62210A | Geostone Grigio Lev/Ret

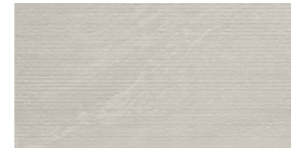

30x60

63560A | Geo Velvet Grigio Grip/Ret



30x30

63660 | Geo Mosaico Grigio Nat/Ret



Imballi

Packing
Verpackung
Emballage

Formato / Size		± MM	Pezzi/Scatola Pieces/Box Stck/Karton Carreaux/Boîte	Mq/Scatola Sqmt/Box Qm/Karton M2/Boîte	Kg/Scatola Kgs/Box Kg/Karton Kg/Boîte	Scatole/Paletta Boxes/Pallet Karton/Pallet Boîte/Palette	Mq/Paletta Sqmt/Pallet Qm/Pallet M2 /Palette	Kg/Paletta Kgs/Pallet Kg/Pallet Kg/Palette	Formato Paletta Size Pallet Format Pallet Dim. Palette
60x120 Nat/Ret	P	9,5	2	1,44	31,0	30	43,20	930	122x82x75
60x120 Lev/Ret	P	9,5	2	1,44	32,0	30	43,20	960	122x82x75
80x80 Nat/Ret	P	9,5	2	1,28	27,5	50	64,00	1375	122x80x96
45x90 Nat/Ret	P	9,5	3	1,215	26,0	36	43,74	936	120x90x60
60x60 Nat/Ret	P	9,5	4	1,44	29	32	46,08	928	120x80x75
60x60 Lev/Ret	P	9,5	4	1,44	30	32	46,08	960	120x80x75
30x60 Nat/Ret	P	9,5	7	1,26	25,30	40	50,40	1012	120x80x75
30x60 Velvet Grip/Ret	P	9,5	7	1,26	25,30	40	50,40	1012	120x80x75
30x60 Esagonetta Ret	P	9,5	7	1,26	25,30	32	40,32	809,6	120x80x75
30x30 Mosaico (Su Rete)	P	9,5	5	0,45	8,5	60			
Pezzi Speciali / Special Pieces									
8x80 Battiscopa	P	9,5	7	0,448	11	65			
7x90 Battiscopa	P	9,5	8	0,504	13	48			
8x60 Battiscopa	P	9,5	10	0,48	11	72			

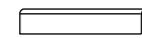

Riepilogo Gamma

Collection
Serie
Gamme

	Formati Sizes									
		60x120 24"x48"	80x80 31½"x31½"	45x90 18"x36"	60x60 24"x24"	30x60 12"x24"	DIN 51130	DIN 51097	DCOF	
	Nat						V3	R10	A	> 0,42
	Nat/Ret	03053A	03841	03708	62150A	62750A				
	Lev/Ret	03057A			62200A					
	Velvet Grip/Ret					63550A	R11	A+B+C	> 0,42	
	Nat						V3	R10	A	> 0,42
	Nat/Ret	03054A	03843	03883	62170A	62780A				
Lev/Ret	03058A			62220A						
	Velvet Grip/Ret					63570A	R11	A+B+C	> 0,42	
	Nat						V3	R10	A	> 0,42
	Nat/Ret	03056A	03842	03485	62190A	62840A				
Lev/Ret	03061A			62240A						
	Velvet Grip/Ret					63590A	R11	A+B+C	> 0,42	
	Nat						V3	R10	A	> 0,42
	Nat/Ret		03844	03884	62180A	62810A				
Lev/Ret				62230A						
	Velvet Grip/Ret					63580A	R11	A+B+C	> 0,42	
	Nat						V3	R10	A	> 0,42
	Nat/Ret	03055A	03718	03711	62160A	62770A				
Lev/Ret	03059A			62210A						
	Velvet Grip/Ret					63560A	R11	A+B+C	> 0,42	

Riepilogo Gamma

Collection
Serie
Gamme

	Formati Sizes	Strutture 3D 3D Structures		Decori Decors	Pezzi Speciali Special Pieces		
		Esagonetta 30x60 12"x24"	Velvet 30x60 12"x24"	Mosaico 30x30 Su Rete 12"x12" (2"x2" Dot)	Battiscopa 7x90 2¾"x36"	Battiscopa 8x80 3¼"x31 ½"	Battiscopa 8x60 3¼"x24"
	Nat						
	Nat/Ret	63600A		63650	65690	00099	65830
	Lev/Ret						66090
	Velvet Grip/Ret		63550A				
	Nat						
	Nat/Ret	63620A		64860	65710	00435	66060
	Lev/Ret						66110
	Velvet Grip/Ret		63570A				
	Nat						
	Nat/Ret	63640A		65680	65730	00101	66080
	Lev/Ret						66130
	Velvet Grip/Ret		63590A				
	Nat						
	Nat/Ret	63630A		64870	65720	00436	66070
	Lev/Ret						66120
	Velvet Grip/Ret		63580A				
	Nat						
	Nat/Ret	63610A		63660	65700	00100	65840
	Lev/Ret						66100
	Velvet Grip/Ret		63560A				

Purestone

Una vera e propria materia d'arredo, ricavata elaborando l'estetica di diverse pietre esistenti in natura. "Purestone" Piemme è un moderno grès porcellanato dai toni delicati e dalle venature discrete, mai eccessive.

A real furnishing material, obtained by processing the aesthetics of various kinds of natural stones, Piemme "Purestone" is a modern porcelain stoneware with delicate colour shades and discreet and never excessive veins.

Ein echtes Einrichtungsmaterial, gewonnen aus einem Mix der Optik verschiedener Natursteine. Piemme "Purestone" ist ein modernes Feinsteinzeug in zarten Tönen und mit dezenten, unaufdringlichen Aderungen.

Cette véritable révolution en matière d'architecture intérieure est le fruit d'une étude précise sur les différentes pierres existant dans la nature. "Purestone" by Piemme est un grès cérame moderne, aux teintes délicates, aux veines discrètes parfaitement dosées.

5

Colori
Colours
Farben
Couleurs

Bianco



Beige

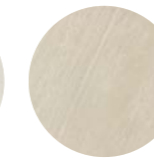

Grigio



Piombo

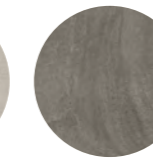

Antracite

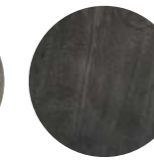

3

Formati
Sizes
Formate
Formats

60×60
24"×24"



30,1×60,4
12"×24"



30×60
12"×24"



3

Superfici
Surfaces
Oberflächen
Surfaces

Naturale

Levigato

Velvet

3

Strutture 3D
3D structures
Strukturen
Decorations and relief

Linea

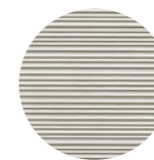

Muretto

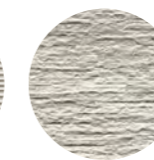

Velvet

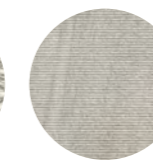

i

Effetto Pietra
Stone Look
Natursteinoptik
Effet Pierre

Rivestimento
Wall Tiles
Wandfliesen
Revêtement

Pavimento
Floor Tiles
Bodenfliesen
Sol

Gres fine porcellanato ad impasto colorato
Coloured-body fine porcelain stoneware
Feinsteinzeug aus farbiger Masse
Grès cérame fin à pâte colorée

Tecnologia digitale
Digital technology
Digital Technologie
Technologie numérique



Bianco



60x60
10840A | Purestone Bianco Nat/Ret
10870A | Purestone Bianco Lev/Ret



30,1x60,4
03774A | Purestone Bianco Nat
30x60
10990A | Purestone Bianco Nat/Ret
11080A | Purestone Bianco Lev/Ret



30x60
00530A | Purestone Bianco Velvet Ret



30x60
00535A | Purestone Linea Bianco Nat/Ret



30x60
11160A | Purestone Muretto Bianco Nat/Ret



30x30
39590 | Purestone Mosaico Bianco Nat/Ret



Beige



60x60
10850A | Purestone Beige Nat/Ret
10880A | Purestone Beige Lev/Ret



30,1x60,4
03775A | Purestone Beige Nat
30x60
11000A | Purestone Beige Nat/Ret
11140A | Purestone Beige Lev/Ret



30x60
00531A | Purestone Beige Velvet Ret

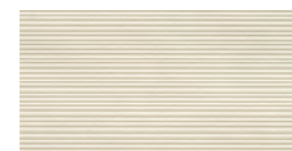

30x60
00536A | Purestone Linea Beige Nat/Ret

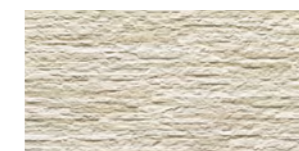

30x60
11300A | Purestone Muretto Beige Nat/Ret

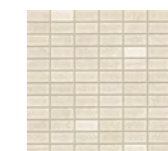

30x30
39600 | Purestone Mosaico Beige Nat/Ret



Grigio



60x60

10860A | Purestone Grigio Nat/Ret
10890A | Purestone Grigio Lev/Ret

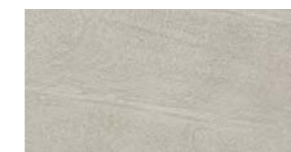

30,1x60,4

03776A | Purestone Grigio Nat
30x60

11070A | Purestone Grigio Nat/Ret
11150A | Purestone Grigio Lev/Ret



30x60

00532A | Purestone Grigio Velvet Ret

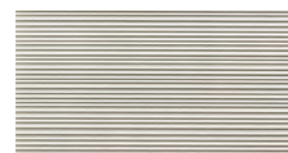

30x60

00537A | Purestone Linea Grigio Nat/Ret

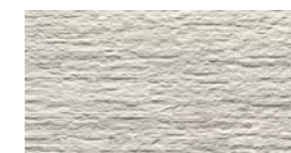

30x60

11310A | Purestone Muretto Grigio Nat/Ret



30x30

39610 | Purestone Mosaico Grigio Nat/Ret



Piombo



60x60

00519A | Purestone Piombo Nat/Ret
00522A | Purestone Piombo Lev/Ret



30,1x60,4

03777A | Purestone Piombo Nat
30x60

00526A | Purestone Piombo Nat/Ret
00528A | Purestone Piombo Lev/Ret



30x60

00533A | Purestone Piombo Velvet Ret



30x60

00538A | Purestone Linea Piombo Nat/Ret



30x60

00725A | Purestone Muretto Piombo/ Antracite Nat/Ret



30x30

00540 | Purestone Mosaico Piombo Nat/Ret

Antracite



60x60

00521A | Purestone Antracite Nat/Ret
00523A | Purestone Antracite Lev/Ret



30,1x60,4

03778A | Purestone Antracite Nat
30x60

00527A | Purestone Antracite Nat/Ret
00529A | Purestone Antracite Lev/Ret

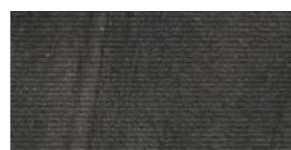

30x60

00534A | Purestone Antracite Velvet Ret



30x60

00539A | Purestone Linea Antracite Nat/Ret



30x60

00725A | Purestone Muretto Piombo/ Antracite Nat/Ret









30x30

00541 | Purestone Mosaico Antracite Nat/Ret



Imballi

Packing
Verpackung
Emballage

Formato / Size		± MM	 Pezzi/Scatola Pieces/Box Stck/Karton Carreaux/Boîte	 Mq/Scatola Sqmt/Box Qm/Karton M2/Boîte	 Kg/Scatola Kgs/Box Kg/Karton Kg/Boîte	 Scatole/Paletta Boxes/Pallet Karton/Pallet Boîte/Palette	 Mq/Paletta Sqmt/Pallet Qm/Pallet M2 /Palette	 Kg/Paletta Kgs/Pallet Kg/Pallet Kg/Palette	 Formato Paletta Size Pallet Format Pallet Dim. Palette
60x60 Nat/Ret	P	9,5	4	1,44	29,00	32	46,08	928	120x80x75
60x60 Lev/Ret	P	9,5	4	1,44	30,00	32	46,08	960	120x80x75
30,1x60,4 Nat	P	9,5	7	1,273	25,70	40	50,92	1028	120x80x75
30x60 Nat/Ret	P	9,5	7	1,26	25,30	40	50,40	1012	120x80x75
30x60 Lev/Ret	P	9,5	7	1,26	26,30	40	50,40	1052	120x80x75
30x60 Velvet Ret	P	9,5	7	1,26	25,30	40	50,40	1012	120x80x75
30x60 Linea Nat/Ret	P	9,5	7	1,26	25,30	32	40,32	809,6	120x80x75
30x60 Muretto Ret	P	9,5	7	1,26	25,30	32	40,32	809,6	120x80x75
30x30 Mosaico (Su Rete)	P	9,5	5	0,45	8,5	60			
Pezzi Speciali / Special Pieces									
8x60 Battiscopa Nat - Nat/Ret - Lev/Ret	P	9,5	10	0,48	11	72			
30x60 Step	P	9,5	6	1,08	22	36			

Riepilogo Gamma

Collection
Serie
Gamme

	Formati Sizes	Formati Sizes			DIN 51130	DIN 51097	DCOF	Strutture 3D 3D Structures		
		60x60 24"x24"	30,1x60,4 12"x24"	30x60 12"x24"				Linea 30x60 12"x24"	Muretto 30x60 12"x24"	Velvet 30x60 12"x24"
Bianco	Nat		03774A		R10	A	> 0,42			
	Nat/Ret	10840A		10990A	V3	R10	A	> 0,42	00535A	11160A
	Lev/Ret	10870A		11080A						
	Velvet/Ret			00530A		R11	A+B+C	> 0,42		
Beige	Nat		03775A			R10	A	> 0,42		
	Nat/Ret	10850A		11000A	V3	R10	A	> 0,42	00536A	11300A
	Lev/Ret	10880A		11140A						
	Velvet/Ret			00531A		R11	A+B+C	> 0,42		
Grigio	Nat		03776A			R10	A	> 0,42		
	Nat/Ret	10860A		11070A	V3	R10	A	> 0,42	00537A	11310A
	Lev/Ret	10890A		11150A						
	Velvet/Ret			00532A		R11	A+B+C	> 0,42		
Piombo	Nat		03777A			R10	A	> 0,42		
	Nat/Ret	00519A		00526A	V3	R10	A	> 0,42	00538A	00725A
	Lev/Ret	00522A		00528A						
	Velvet/Ret			00533A		R11	A+B+C	> 0,42		
Antracite	Nat		03778A			R10	A	> 0,42		
	Nat/Ret	00521A		00527A	V3	R10	A	> 0,42	00539A	00725A
	Lev/Ret	00523A		00529A						
	Velvet/Ret			00534A		R11	A+B+C	> 0,42		

Riepilogo Gamma

Collection
Serie
Gamme

	Formati Sizes	Formati Sizes	Pezzi Speciali Special Pieces	
			Mosaico 30x30 (Su Rete) 12"x12" 1"x2" Dot	Battiscopa 8x60 3/4"x24"
Bianco	Nat		11320	11390
	Nat/Ret	39590	71980	
	Lev/Ret		72010	
Beige	Nat		11330	11400
	Nat/Ret	39600	71990	
	Lev/Ret		72020	
Grigio	Nat		11380	11410
	Nat/Ret	39610	72000	
	Lev/Ret		72030	
Piombo	Nat		00542	00550
	Nat/Ret	00540	00544	
	Lev/Ret		00546	
Antracite	Nat		00543	00551
	Nat/Ret	00541	00545	
	Lev/Ret		00547	

Castlestone

Con Castlestone il fascino della pietra è ora al servizio dell'arredamento architettonico.

Thanks to Castlestone, the appeal of stone is now at the service of architectural design.

Mit Castlestone steht der Zauber des Natursteins heute im Dienst der architektonischen Raumgestaltung.

Avec Castlestone, le charme de la pierre est maintenant au service de l'architecture d'intérieur.

5

Colori
Colours
Farben
Couleurs

White



Almond

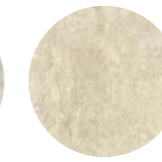

Grey



Musk



Black

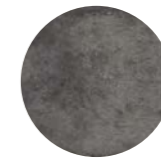

3

Formati
Sizes
Formate
Formats

60×60
24"×24"



45×90
18"×36"



30×60
12"×24"



3

Superfici
Surfaces
Oberflächen
Surfaces

Naturale

Lappato

Antislip

1

Strutture 3D
3D structures
Strukturen
Decorations and relief

Muretto



i

Effetto Pietra
Stone Look
Natursteinoptik
Effet Pierre

Rivestimento
Wall Tiles
Wandfliesen
Revêtement

Pavimento
Floor Tiles
Bodenfliesen
Sol

Gres fine porcellanato ad impasto colorato
Coloured-body fine porcelain stoneware
Feinsteinzeug aus farbiger Masse
Grès cérame fin à pâte colorée

Tecnologia digitale
Digital technology
Digital Technologie
Technologie numérique



White



60x60
00126A | Castlestone White Nat/Ret
00131A | Castlestone White Lap/Ret



60x60
00456A | Castlestone Antislip White Ret



30x60
00224A | Castlestone Mix Cold Ret



30x60
00149A | Castlestone Muretto White Ret



45x90
03877 | Castlestone White Nat/Ret



30x60
00136A | Castlestone White Nat/Ret

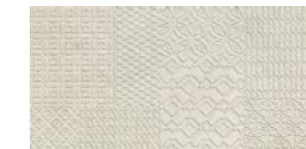

30x60
***00282** | Castlestone Inciso White Ret

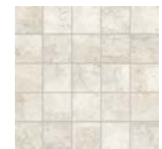

30x30
00159 | Castlestone Mosaico White Ret

Almond



60x60
00127A | Castlestone Almond Nat/Ret
00132A | Castlestone Almond Lap/Ret



60x60
00457A | Castlestone Antislip Almond Ret



30x60
00225A | Castlestone Mix Warm Ret



30x60
00150A | Castlestone Muretto Almond Ret

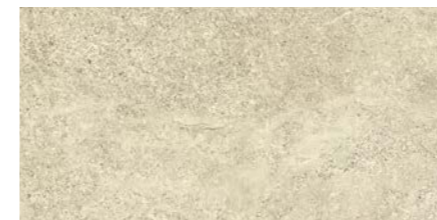

45x90
03704 | Castlestone Almond Nat/Ret

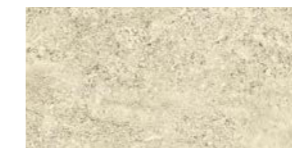

30x60
00137A | Castlestone Almond Nat/Ret



30x60
***00283** | Castlestone Inciso Almond Ret

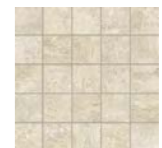

30x30
00160 | Castlestone Mosaico Almond Ret

* Decori realizzati con smalti e metalli preziosi. Vedere nota a pag. 366-367
Decors made with glazes and precious metals. See note on pages 366-367
Dekore aus Glasuren und Edelmetallen. Siehe Hinweis auf Seiten 366-367
Décors réalisés avec des émaux et des métaux précieux. Voir note aux pages 366-367





Grey



60x60
00128A | Castlestone Grey Nat/Ret
00133A | Castlestone Grey Lap/Ret



60x60
00458A | Castlestone Antislip Grey Ret



30x60
00224A | Castlestone Mix Cold Ret



30x60
00151A | Castlestone Muretto Grey Ret



45x90
03706 | Castlestone Grey Nat/Ret



30x60
00138A | Castlestone Grey Nat/Ret



30x60
***00284** | Castlestone Inciso Grey Ret

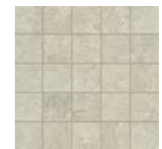

30x30
00161 | Castlestone Mosaico Grey Ret



Musk



60x60
00129A | Castlestone Musk Nat/Ret
00134A | Castlestone Musk Lap/Ret



60x60
00459A | Castlestone Antislip Musk Ret



30x60
00225A | Castlestone Mix Warm Ret



30x60
00152A | Castlestone Muretto Musk Ret



45x90
03707 | Castlestone Musk Nat/Ret



30x60
00139A | Castlestone Musk Nat/Ret

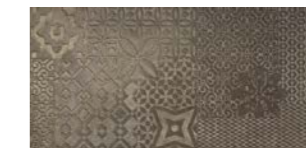

30x60
***00285** | Castlestone Inciso Musk Lap/Ret

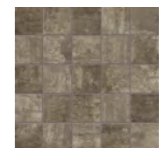

30x30
00162 | Castlestone Mosaico Musk Ret

* Decori realizzati con smalti e metalli preziosi. Vedere nota a pag. 366-367
Decors made with glazes and precious metals. See note on pages 366-367
Dekore aus Glasuren und Edelmetallen. Siehe Hinweis auf Seiten 366-367
Décors réalisés avec des émaux et des métaux précieux. Voir note aux pages 366-367

Black



60x60
00130A | Castlestone Black Nat/Ret
00135A | Castlestone Black Lap/Ret



60x60
00460A | Castlestone Antislip Black Ret



30x60
00224A | Castlestone Mix Cold Ret

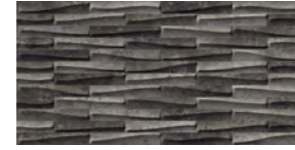

30x60
00153A | Castlestone Muretto Black Ret



45x90
03881 | Castlestone Black Nat/Ret



30x60
00141A | Castlestone Black Nat/Ret



30x60
***00286** | Castlestone Inciso Black Lap/Ret

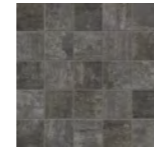

30x30
00163 | Castlestone Mosaico Black Ret

* Decori realizzati con smalti e metalli preziosi. Vedere nota a pag. 366-367
Decors made with glazes and precious metals. See note on pages 366-367
Dekore aus Glasuren und Edelmetallen. Siehe Hinweis auf Seiten 366-367
Décors réalisés avec des émaux et des métaux précieux. Voir note aux pages 366-367



Imballi

Packing
Verpackung
Emballage

Formato / Size	MM	± MM	Pezzi/Scatola Pieces/Box Stck/Karton Carreaux/Boîte	Mq/Scatola Sqmt/Box Qm/Karton M2/Boîte	Kg/Scatola Kgs/Box Kg/Karton Kg/Boîte	Scatole/Paletta Boxes/Pallet Karton/Pallet Boîte/Palette	Mq/Paletta Sqmt/Pallet Qm/Pallet M2 /Palette	Kg/Paletta Kgs/Pallet Kg/Pallet Kg/Palette	Formato Paletta Size Pallet Format Pallet Dim. Palette
45x90 Nat/Ret	P	9,5	3	1,215	26,0	36	43,74	936	120x90x60
60x60 Nat/Ret	P	9,5	4	1,44	29	32	46,08	928	120x80x75
60x60 Antislip/Ret	P	9,5	4	1,44	29	32	46,08	928	120x80x75
60x60 Lap/Ret	P	9,5	4	1,44	30	32	46,08	960	120x80x75
30x60 Nat/Ret	P	9,5	7	1,26	25,30	40	50,40	1012	120x80x75
30x60 Muretto	P	9,5	7	1,26	25,30	32	40,32	809,60	120x80x75
30x60 Mix	P	9,5	7	1,26	25,30	40	50,40	1012	120x80x75
30x60 Inciso	P	9,5	6	1,08	21,5	21	22,68	451,5	120x80x75
30x30 Mosaico (Su Rete)	P	9,5	5	0,45	8,5	60			
Pezzi Speciali / Special Pieces									
7x90 Battiscopa	P	9,5	8	0,504	13	48			
8x60 Battiscopa	P	9,5	10	0,48	11	72			
30x60 Step	P	9,5	6	1,08	21,5	36			

Riepilogo Gamma

Collection
Serie
Gamme

Formati Sizes	Structure 3D 3D Structures			Pezzi Speciali Special Pieces							
	Muretto 30x60 12"x24"	Mix Warm 30x60 12"x24"	Mix Cold 30x60 12"x24"	Inciso 30x60 12"x24"	Mosaico 30x30 (Su Rete) 12"x12" 2"x2" Dot	Battiscopa 7x90 2¾"x36"	Battiscopa 8x60 3¼"x24"	Step 30x60 12"x24"			
	± 9,5	± 9,5	± 9,5	± 9,5	± 9,5	± 9,5	± 9,5	± 9,5			
White	Nat/Ret 03877	Lap/Ret 00126A	Antislip/Ret 00456A	Muretto 00136A	Mix Warm 00131A	Mix Cold 00137A	Inciso 00138A	Mosaico 00139A	Battiscopa 00199	Battiscopa 00179	Step 00189
Almond	Nat/Ret 03704	Lap/Ret 00132A	Antislip/Ret 00457A	Muretto 00137A	Mix Warm 00132A	Mix Cold 00132A	Inciso 00137A	Mosaico 00137A	Battiscopa 00200	Battiscopa 00180	Step 00190
Grey	Nat/Ret 03706	Lap/Ret 00133A	Antislip/Ret 00458A	Muretto 00138A	Mix Warm 00133A	Mix Cold 00138A	Inciso 00138A	Mosaico 00138A	Battiscopa 00201	Battiscopa 00181	Step 00191
Musk	Nat/Ret 03707	Lap/Ret 00134A	Antislip/Ret 00459A	Muretto 00139A	Mix Warm 00134A	Mix Cold 00139A	Inciso 00139A	Mosaico 00139A	Battiscopa 00202	Battiscopa 00182	Step 00192
Black	Nat/Ret 03881	Lap/Ret 00135A	Antislip/Ret 00460A	Muretto 00141A	Mix Warm 00135A	Mix Cold 00141A	Inciso 00141A	Mosaico 00141A	Battiscopa 00203	Battiscopa 00183	Step 00193

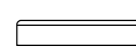

More

More è una moderna superficie di design; un equilibrato blend di pietre messo a punto dalla ricerca Piemme e declinato in numerosi formati e finiture; il tutto arricchito da superfici tridimensionali e decorazioni coordinate che rendono More un vero e proprio materiale d'architettura.

More is a modern design surface; it is a balanced blend of stones developed by Piemme research and available in numerous shapes and finishes; all this is enhanced by three-dimensional surfaces and decorations which make More a real architectural material.

More ist eine moderne Design-Oberfläche; ein ausgewogener Mix aus Steinen aus den Piemme-Forschungslabors. In zahlreichen Formaten und Oberflächenversionen erhältlich. Bereichert durch 3D-Oberflächen und passend abgestimmte Dekore, die More zu einem wahren Architektur-Material machen.

More est une surface au design moderne, un mélange subtilement dosé de pierres mis au point par la Recherche Piemme, décliné en de nombreux formats et finitions. Le tout est enrichi de surfaces tridimensionnelles et de décors coordonnés faisant de More un matériau d'architecture proprement dit.

5

Colori
Colours
Farben
Couleurs

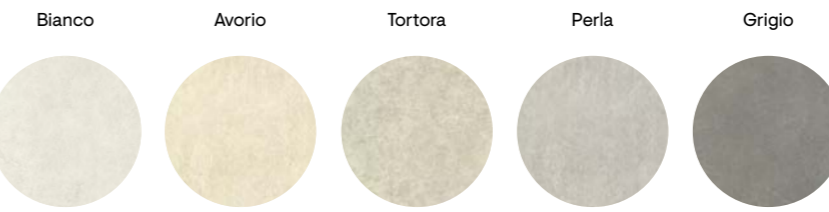

2

Formati
Sizes
Formate
Formats

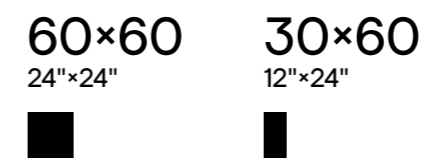

2

Superfici
Surfaces
Oberflächen
Surfaces

Naturale Velvet

3

Strutture 3D
3D structures
Strukturen
Decorations and relief



i

Effetto Pietra
Stone Look
Natursteinoptik
Effet Pierre

Rivestimento
Wall Tiles
Wandfliesen
Revêtement

Pavimento
Floor Tiles
Bodenfliesen
Sol

Gres fine porcellanato ad impasto colorato
Coloured-body fine porcelain stoneware
Feinsteinzeug aus farbiger Masse
Grès cérame fin à pâte colorée

Tecnologia digitale
Digital technology
Digital Technologie
Technologie numérique



Bianco



60x60
00601A | More Bianco Nat/Ret



30x60
00612A | More Bianco Nat/Ret



30x60
00654A | More Velvet Bianco Ret



30x60
00648A | More Design Bianco Ret



30x60
00719A | More Muretto Bianco Ret



30x30
00659 | More Mosaico Bianco Nat/Ret



10x30
00665 | More Bianco Nat/Ret

Avorio



60x60
00603A | More Avorio Nat/Ret

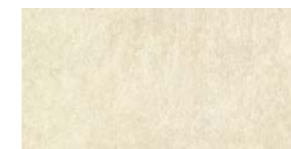

30x60
00614A | More Avorio Nat/Ret

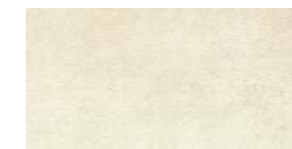

30x60
00656A | More Velvet Avorio Ret

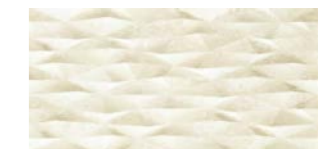

30x60
00651A | More Design Avorio Ret



30x60
00722A | More Muretto Avorio Ret

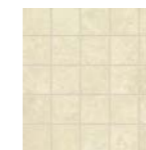

30x30
00662 | More Mosaico Avorio Nat/Ret



10x30
00667 | More Avorio Nat/Ret



Tortora



60x60
00604A | More Tortora Nat/Ret



30x60
00615A | More Tortora Nat/Ret



30x60
00657A | More Velvet Tortora Ret



30x60
00652A | More Design Tortora Ret



30x60
00723A | More Muretto Tortora Ret



30x30
00663 | More Mosaico Tortora Nat/Ret



10x30
00668 | More Tortora Nat/Ret

Perla



60x60
00602A | More Perla Nat/Ret

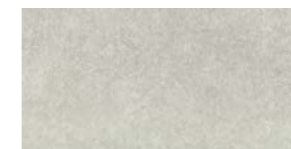

30x60
00613A | More Perla Nat/Ret

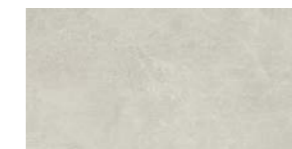

30x60
00655A | More Velvet Perla Ret

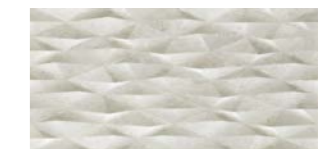

30x60
00649A | More Design Perla Ret

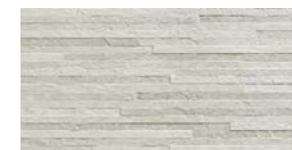

30x60
00721A | More Muretto Perla Ret

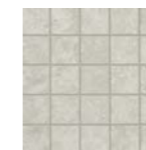

30x30
00661 | More Mosaico Perla Nat/Ret

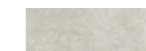

10x30
00666 | More Perla Nat/Ret

Grigio



60x60
00605A | More Grigio Nat/Ret



30x60
00616A | More Grigio Nat/Ret



30x60
00658A | More Velvet Grigio Ret

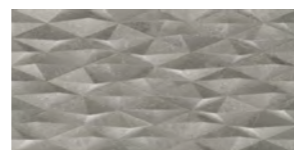

30x60
00653A | More Design Grigio Ret

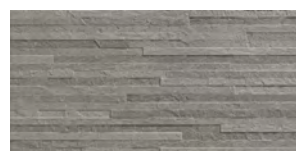

30x60
00724A | More Muretto Grigio Ret



30x30
00664 | More Mosaico Grigio Nat/Ret



10x30
00669 | More Grigio Nat/Ret



Imballi

Packing
Verpackung
Emballage

Formato / Size		± MM	Pezzi/Scatola Pieces/Box Stck/Karton Carreaux/Boîte	Mq/Scatola Sqmt/Box Qm/Karton M2/Boîte	Kg/Scatola Kgs/Box Kg/Karton Kg/Boîte	Scatole/Paletta Boxes/Pallet Karton/Pallet Boîte/Palette	Mq/Paletta Sqmt/Pallet Qm/Pallet M2 /Palette	Kg/Paletta Kgs/Pallet Kg/Pallet Kg/Palette	Formato Paletta Size Pallet Format Pallet Dim. Palette
60x60 Nat/Ret	P	9,5	4	1,44	29,00	32	46,08	928	120x80x75
30x60 Nat/Ret	P	9,5	7	1,26	25,30	40	50,4	1012	120x80x75
30x60 Design	P	9,5	7	1,26	25,30	32	40,32	809,6	120x80x75
30x60 Muretto	P	9,5	7	1,26	25,30	32	40,32	809,6	120x80x75
30x60 Velvet	P	9,5	7	1,26	25,30	40	50,4	1012	120x80x75
30x30 Mosaico (Su Rete)	P	9,5	5	0,45	8,5	60			
10x30	P	9,5	12	0,36	7,4	84			
Pezzi Speciali / Special Pieces									
8x60 Battiscopa	P	9,5	10	0,48	11	72			
30x60 Step	P	9,5	6	1,08	21,5	36			

Riepilogo Gamma

Collection
Serie
Gamme

Formati Sizes	60x60 24"x24"		30x60 12"x24"		UPEC			Strutture 3D 3D Structures			Pezzi Speciali Special Pieces			
	± 9,5	± 9,5	DIN 51130	DIN 51097	DCOF	Design 30x60 12"x24"	Muretto 30x60 12"x24"	Velvet 30x60 12"x24"	Mosaico 30x30 (Su Rete) 12"x12" (2"x2" Dot)	10x30 4"x12"	Battiscopa 8x60 3 1/4"x24"	Step 30x60 12"x24"		
Bianco	Nat/Ret	00601A	00612A	V3	R10	A	> 0,42	00648A	00719A		00659	00665	00682	00693
	Velvet/Ret		00654A		R11	A+B+C	> 0,42			00654A				
Avorio	Nat/Ret	00603A	00614A	V3	R10	A	> 0,42	00651A	00722A		00662	00667	00684	00695
	Velvet/Ret		00656A		R11	A+B+C	> 0,42			00656A				
Tortora	Nat/Ret	00604A	00615A	V3	R10	A	> 0,42	00652A	00723A		00663	00668	00685	00696
	Velvet/Ret		00657A		R11	A+B+C	> 0,42			00657A				
Perla	Nat/Ret	00602A	00613A	V3	R10	A	> 0,42	00649A	00721A		00661	00666	00683	00694
	Velvet/Ret		00655A		R11	A+B+C	> 0,42			00655A				
Grigio	Nat/Ret	00605A	00616A	V3	R10	A	> 0,42	00653A	00724A		00664	00669	00686	00697
	Velvet/Ret		00658A		R11	A+B+C	> 0,42			00658A				



CEMENT EFFECT

Effetto Cemento / Beton Optik / Effet Béton

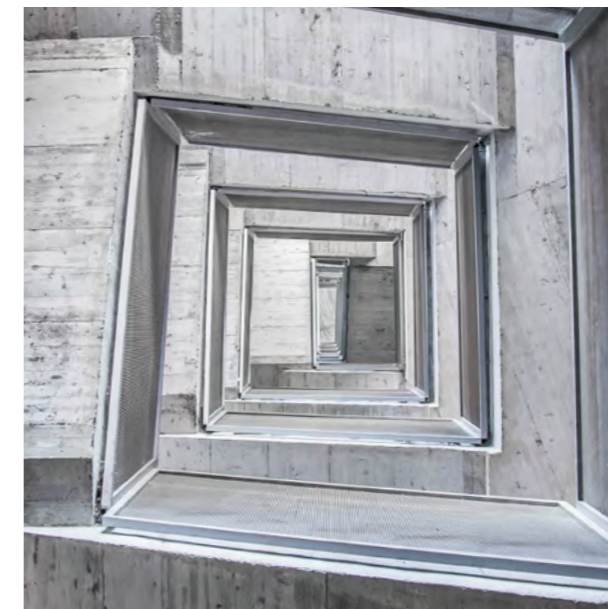

CLICK



- 142 [Glitch](#) FLOOR AND MORE /
- 162 [Shades](#) FLOOR AND MORE /
- 174 [Urban](#) FLOOR AND MORE

Glitch

Designed by Benoy

Glitch è una gamma di piastrelle in grès porcellanato sviluppata da Piemme in collaborazione con uno dei maggiori studi di design a livello internazionale: Benoy. Glitch si propone di valorizzare le caratteristiche disomogenee presenti nel calcestruzzo e tutte quelle piccole imperfezioni che caratterizzano questa superficie, come crepe, patine, graffi ed i segni lasciati nel tempo dagli agenti atmosferici.

Glitch is a range of porcelain stoneware tiles developed by Piemme in partnership with one of the biggest international design studios: Benoy. Glitch brings out and highlights the heterogeneous nature of concrete, and all those little imperfections characteristic of this surface, such as cracks, patinas, scratches and weathering.

Glitch ist eine Fliesenserie aus Feinsteinzeug, die Piemme in Kooperation mit dem namhaften Designbüro Benoy entwickelte. Glitch bringt die Betonoberfläche in ihrer Unvollkommenheit, samt all ihren kleinen Makeln wie Risse, Ablagerungen, Kratzer und Verwitterungserscheinungen.

Glitch est une collection de carreaux en grès cérame imaginée par Piemme en collaboration avec l'un des plus prestigieux bureaux de design sur la scène internationale: Benoy. Glitch veut mettre en valeur les hétérogénéités du béton, ainsi que toutes les petites imperfections distinctives de cette surface, comme les craquements, les patines, les rayures et les signes que les agents atmosphériques laissent au fil du temps.

8

Colori
Colours
Farben
Couleurs

Salt



Sand



Gravel



Clay



Ash



Flint



Graphite

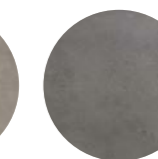

Carbon



5

Formati
Sizes
Formate
Formats

120×120
48"×48"



60×120
24"×48"



80×80
31½"×31½"



60×60
24"×24"



30×60
12"×24"



3

Superfici
Surfaces
Oberflächen
Surfaces

Naturale

Antislip

Grip

1

Strutture 3D
3D structures
Strukturen
Decorations and relief

Fault

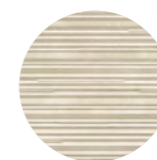

i

Effetto Cemento
Cement Look
Beton Optik
Effet Béton

Rivestimento
Wall Tiles
Wandfliesen
Revêtement

Pavimento
Floor Tiles
Bodenfliesen
Sol

Gres fine porcellanato ad impasto colorato
Coloured-body fine porcelain stoneware
Feinsteinzeug aus farbiger Masse
Grès cérame fin à pâte colorée

Tecnologia digitale
Digital technology
Digital technologie
Technologie numérique

Ripresa grafica tra le diverse lastre rettificata contenuta entro le tolleranze previste dalla norma. Per un corretto allineamento si consiglia di utilizzare una fuga di 2 mm.
Graphic representation between the rectified tiles is contained within the tolerances provided by the standard. For a correct alignment it is recommended to use a 2 mm joint.
Grafische Darstellung zwischen den verschiedenen rektifizierten Platten innerhalb der in der Norm vorgesehenen Toleranzen. Für eine korrekte Anpassung wird eine Fuge von 2mm empfohlen.
Reproduction graphique entre les différents carreaux rectifiés dans les limites des tolérances prévues par la norme. Pour un alignement correct, il est recommandé d'utiliser joints de 2 mm.

▶ WATCH THE VIDEO



Salt

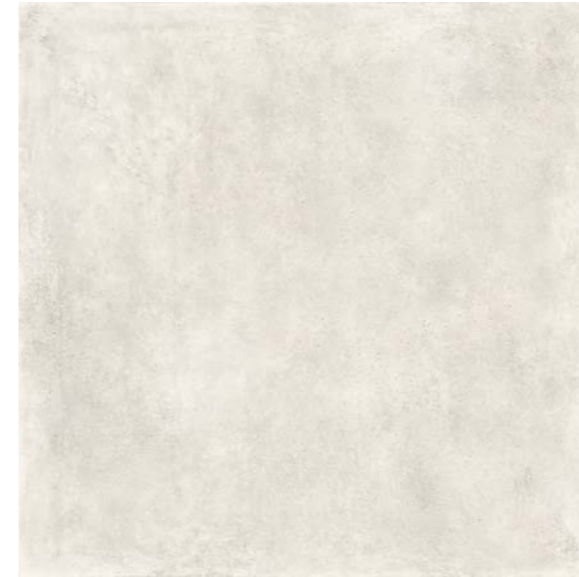

120x120
03292A | Glitch Salt Nat/Ret



80x80
05288 | Glitch Salt Nat/Ret



60x60
03285A | Glitch Salt Nat/Ret
03465A | Glitch Salt Antislip/Ret



60x120
03267A | Glitch Salt Nat/Ret



60x120
03298A | Glitch Fault Salt Nat/Ret



30x60
03276A | Glitch Salt Nat/Ret



60x120
03304A | Glitch Mix Warm Nat/Ret

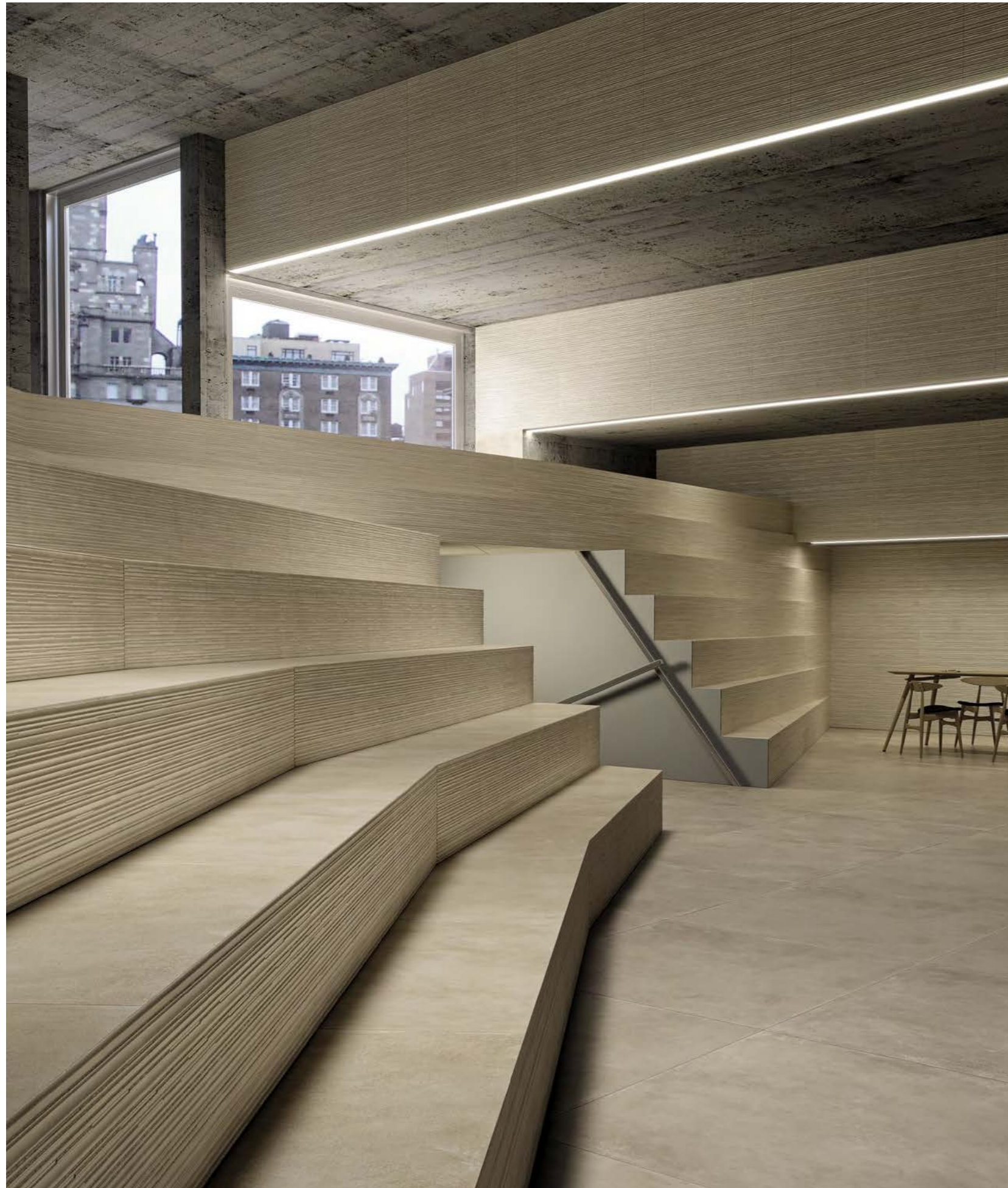

Sand

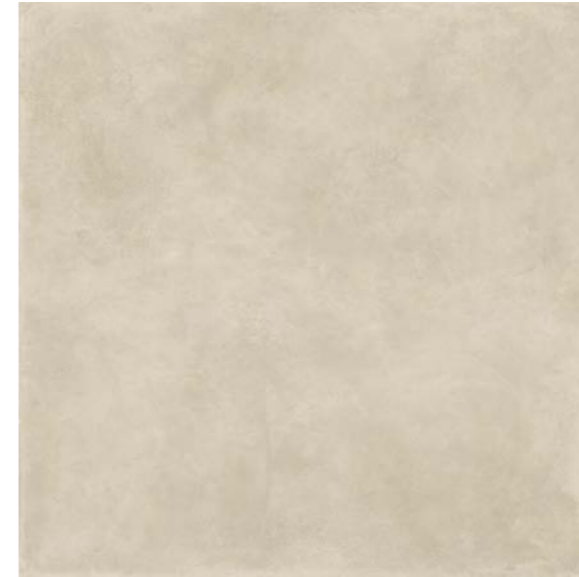

120x120

05363 | Glitch Sand Nat/Ret



60x60

03284A | Glitch Sand Nat/Ret
03891B | Glitch Sand Grip/Ret ± 20mm

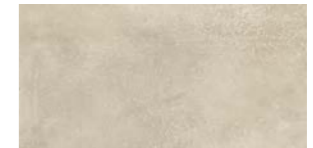

30x60

03275A | Glitch Sand Nat/Ret

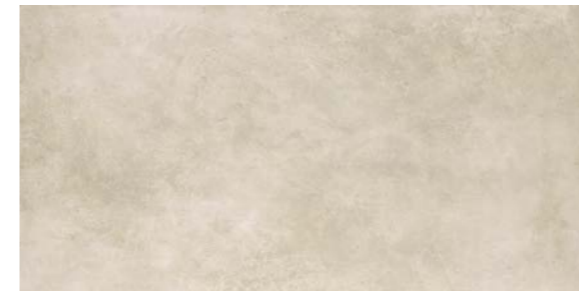

60x120

03266A | Glitch Sand Nat/Ret
05579 | Glitch Sand Grip/Ret ± 20mm



60x120

03297A | Glitch Fault Sand Nat/Ret



60x120

03304A | Glitch Mix Warm Nat/Ret



Gravel



120x120
03291A | Glitch Gravel Nat/Ret



80x80
05287 | Glitch Gravel Nat/Ret



60x60
03283A | Glitch Gravel Nat/Ret
03464A | Glitch Gravel Antislip/Ret
03889B | Glitch Gravel Grip/Ret \pm 20mm

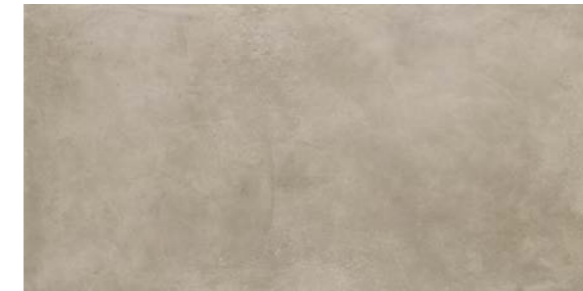

60x120
03265A | Glitch Gravel Nat/Ret
05580 | Glitch Gravel Grip/Ret \pm 20mm



60x120
03296A | Glitch Fault Gravel Nat/Ret

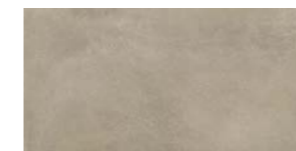

30x60
03274A | Glitch Gravel Nat/Ret



60x120
03304A | Glitch Mix Warm Nat/Ret



Clay



60x120
03264A | Glitch Clay Nat/Ret



60x60
03282A | Glitch Clay Nat/Ret



30x60
03273A | Glitch Clay Nat/Ret



60x120
03295A | Glitch Fault Clay Nat/Ret



60x120
03304A | Glitch Mix Warm Nat/Ret



Ash

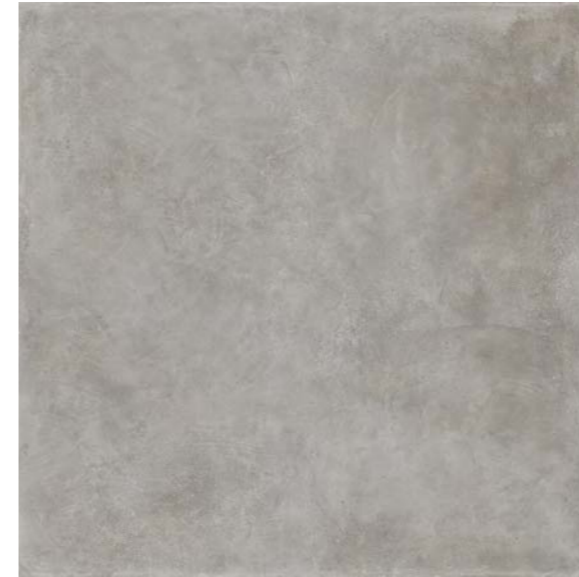

120x120
03293A | Glitch Ash Nat/Ret



80x80
05289 | Glitch Ash Nat/Ret



60x60
03286A | Glitch Ash Nat/Ret
03466A | Glitch Ash Antislip/Ret
03892B | Glitch Ash Grip/Ret \pm 20mm



60x120
03268A | Glitch Ash Nat/Ret
05581 | Glitch Ash Grip/Ret \pm 20mm



60x120
03299A | Glitch Fault Ash Nat/Ret

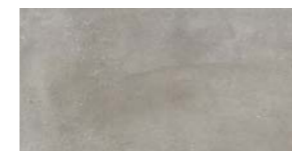

30x60
03277A | Glitch Ash Nat/Ret



60x120
03305A | Glitch Mix Cold Nat/Ret



Flint



60x120
03269A | Glitch Flint Nat/Ret



60x60
03287A | Glitch Flint Nat/Ret



30x60
03278A | Glitch Flint Nat/Ret

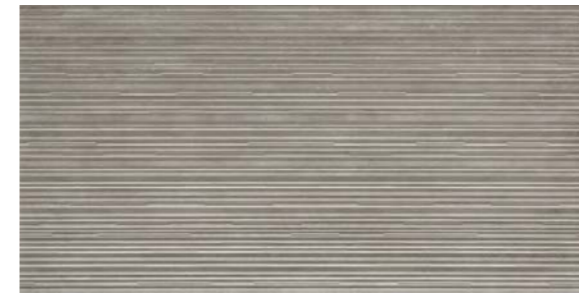

60x120
03301A | Glitch Fault Flint Nat/Ret



60x120
03305A | Glitch Mix Cold Nat/Ret



Graphite

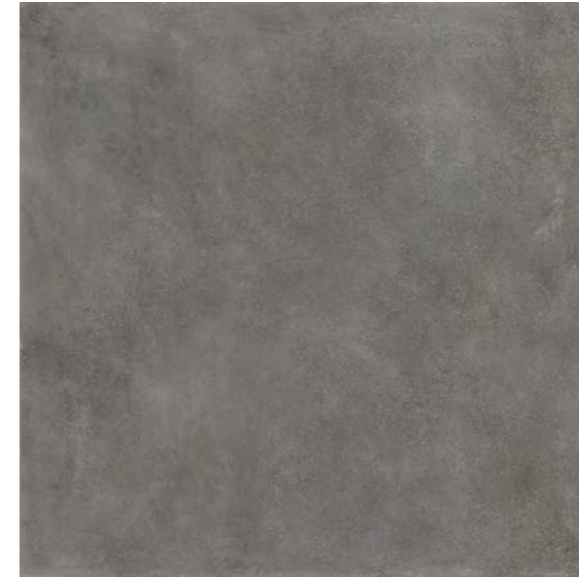

120x120
03294A | Glitch Graphite Nat/Ret



80x80
05291 | Glitch Graphite Nat/Ret



60x60
03288A | Glitch Graphite Nat/Ret
03467A | Glitch Graphite Antislip/Ret

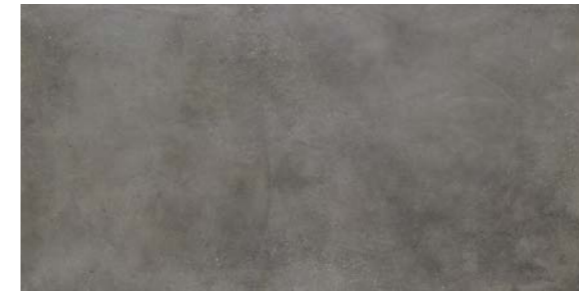

60x120
03271A | Glitch Graphite Nat/Ret

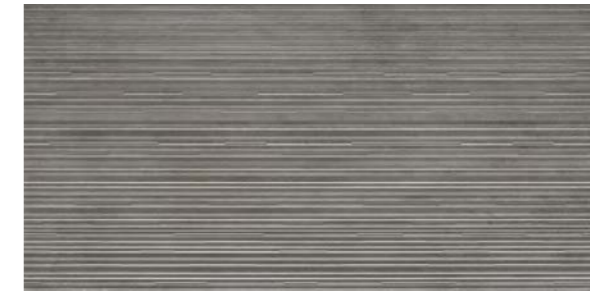

60x120
03302A | Glitch Fault Graphite Nat/Ret



30x60
03279A | Glitch Graphite Nat/Ret



60x120
03305A | Glitch Mix Cold Nat/Ret

Carbon



60x120

03272A | Glitch Carbon Nat/Ret



60x60

03289A | Glitch Carbon Nat/Ret

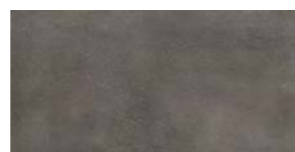

30x60

03281A | Glitch Carbon Nat/Ret



60x120

03303A | Glitch Fault Carbon Nat/Ret









60x120

03305A | Glitch Mix Cold Nat/Ret

Imballi

Packing
Verpackung
Emballage

Formati Sizes		± MM	 Pezzi Scatola Pieces/Box Stck/Karton Carreaux/Boîte	 Mq/Scatola Sqmt/Box Qm/Karton M2/Boîte	 Kg/Scatola Kgs/Box Kg/Karton Kg/Boîte	 Scatole/Paletta Boxes/Pallet Karton/Palette Boîte/Palette	 Mq/Paletta Sqmt/Pallet Qm/Pallet M2/Palette	 Kg/Paletta Kgs/Pallet Kg/Pallet Kg/Palette	 Formato Paletta Size Pallet Format Pallet Dim. Palette
120x120 (48"x48") Nat/Ret	P	9,5	2	2,88	58,00	22	63,36	1276	135x122x68
80x80 (31½"x31½") Nat/Ret	P	9,5	2	1,28	27,50	50	64,00	1375	122x80x96
60x120 (24"x48") Nat/Ret	P	9,5	2	1,44	31,00	30	43,20	930	122x82x75
60x120 (24"x48") Grip/Ret	P	20	1	0,72	33,00	36	25,92	1188	122x96x75
60x60 (24"x24") Nat/Ret	P	9,5	4	1,44	29,00	32	46,08	928	120x80x75
60x60 (24"x24") Antislip/Ret	P	9,5	4	1,44	29,00	32	46,08	928	120x80x75
60x60 (24"x24") Grip/Ret	P	20	2	0,72	32,40	32	23,04	1036,8	120x80x75
30x60 (12"x24") Nat/Ret	P	9,5	7	1,26	25,30	40	50,40	1012	120x80x75
60x120 (24"x48") Fault Nat/Ret	P	9,5	2	1,44	31,00	30	43,20	930	122x82x75
60x120 (24"x48") Mix Nat/Ret	P	9,5	2	1,44	31,00	30	43,20	930	122x82x75
Pezzi Speciali / Special Pieces									
33x120 (13"x48") Gradino Costa Retta Nat/Ret	P	9,5	2	0,792	18,50	20	-	-	-
4,5x60 (1¾"x24") Battiscopa Nat/Ret	P	9,5	14	0,378	8,00	80	-	-	-
1,5x120 (¾"x48") Bacchetta Jolly Nat/Ret	P	9,5	6	0,108	2,50	48	-	-	-
1,5x1,5 (¾"x¾") Unghia Jolly Nat/Ret	P	9,5	6	0,001	0,50	48	-	-	-

Riepilogo Gamma

Collection
Serie
Gamme

									UPEC					
Formati Sizes		120x120 48"x48"	80x80 31½"x31½"	60x120 24"x48"	60x120 24"x48"	60x60 24"x24"	60x60 24"x24"	30x60 12"x24"	DIN 51130	DIN 51097	DCOF	BS EN 7976-2	AS 4586 2013	
		± 9,5	± 9,5	± 9,5	± 20	± 9,5	± 20	± 9,5						
Warm Tones	Nat/Ret	03292A	05288	03267A		03285A		03276A	V2	R10	A+B		wet, dry >36	P3
	Antislip/Ret					03465A				R11	A+B+C	> 0,42	wet, dry >36	P4
Salt	Nat/Ret	05363		03266A		03284A		03275A	V2	R10	A+B		wet, dry >36	P3
	Grip/Ret				05579		03891B			R11	A+B+C	> 0,42		
Sand	Nat/Ret	03291A	05287	03265A		03283A		03274A	V2	R10	A+B		wet, dry >36	P3
	Antislip/Ret					03464A				R11	A+B+C	> 0,42	wet, dry >36	P4
	Grip/Ret				05580		03889B			R11	A+B+C	> 0,42		
Gravel	Nat/Ret			03264A		03282A		03273A	V2	R10	A+B		wet, dry >36	P3
	Antislip/Ret									R11	A+B+C	> 0,42	wet, dry >36	P4
Clay	Nat/Ret								V2	R10	A+B		wet, dry >36	P3
	Antislip/Ret									R11	A+B+C	> 0,42	wet, dry >36	P4
	Grip/Ret				05581		03892B			R11	A+B+C	> 0,42		
Cold Tones	Nat/Ret	03293A	05289	03268A		03286A		03277A	V2	R10	A+B		wet, dry >36	P3
	Antislip/Ret					03466A				R11	A+B+C	> 0,42	wet, dry >36	P4
Ash	Nat/Ret				05581		03892B		V2	R10	A+B		wet, dry >36	P3
	Antislip/Ret									R11	A+B+C	> 0,42	wet, dry >36	P4
Flint	Nat/Ret			03269A		03287A		03278A	V2	R10	A+B		wet, dry >36	P3
	Antislip/Ret									R11	A+B+C	> 0,42	wet, dry >36	P4
Graphite	Nat/Ret	03294A	05291	03271A		03288A		03279A	V2	R10	A+B		wet, dry >36	P3
	Antislip/Ret					03467A				R11	A+B+C	> 0,42	wet, dry >36	P4
Carbon	Nat/Ret			03272A		03289A		03281A	V2	R10	A+B		wet, dry >36	P3
	Antislip/Ret									R11	A+B+C	> 0,42	wet, dry >36	P4

Riepilogo Gamma

Collection
Serie
Gamme

CLICK

PDF Merchandising

				Pezzi Speciali Special Pieces			
Formati Sizes		Fault 60x120 24"x48"	Mix 60x120 24"x48"	Gradino Costa Retta 33x120 13"x48"	Battiscopa 4,5x60 1½"x24"	Bacchetta Jolly 1,5x120 ¾"x48"	Unghia Jolly 1,5x1,5 ¾"x¾"
		± 9,5	± 9,5	± 9,5	± 9,5	± 9,5	± 9,5
Warm Tones	Nat/Ret	03298A	03304A	03321A	03313	03329A	03338
	Antislip/Ret						
Salt	Nat/Ret	03297A	03304A	03320A	03312	03328A	03337
	Antislip/Ret						
Sand	Nat/Ret	03296A	03304A	03731A	03311	03327A	03336
	Antislip/Ret						
Gravel	Nat/Ret	03295A	03304A	03318A	03310	03326A	03335
	Antislip/Ret						
Clay	Nat/Ret	03299A	03305A	03732A	03314	03331A	03339
	Antislip/Ret						
Ash	Nat/Ret	03301A	03305A	03323A	03315	03332A	03341
	Antislip/Ret						
Flint	Nat/Ret	03302A	03305A	03324A	03316	03333A	03342
	Antislip/Ret						
Graphite	Nat/Ret	03303A	03305A	03325A	03317	03334A	03343
	Antislip/Ret						

Shades

Designed by Gordon Guillaumier

Quando l'esattezza della tecnologia incontra l'imprecisione spontanea del decoro fatto a mano: la serialità e la molteplicità della produzione replicano incessantemente ogni istante in cui il segno è rimasto sospeso e delicato, quasi tremante e fanciullesco.

When the accuracy of technology meets the spontaneous imperfections of handmade decorations, that surprising décor effects come to light the multiplicity of the production incessantly replicate every instant in which the stroke is applied, suspended and delicate, almost trembling and childlike.

Die Präzision der Technologie trifft auf die spontane Unbestimmtheit des handgemalten Dekors: Serialität und Vielzahl der Produktion replizieren unaufhörlich jenen Augenblick, in dem das Zeichen in der Schwebe bleibt. Unschärf, beinahe bebend und kindlich.

Lorsque la précision de la technologie rencontre l'imprécision spontanée de la décoration faite à la main: le caractère en série de la production et sa multiplicité reproduisent sans cesse chaque instant où le signe reste en suspens, délicat, presque tremblant et enfantin.

5

Colori
Colours
Farben
Couleurs

Noon



Dawn



Dusk

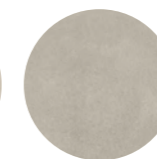

Evening

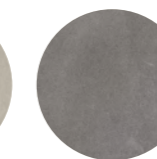

Night

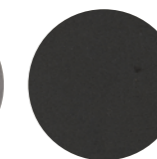

5

Formati
Sizes
Formate
Formats

60×120
24"×48"



80×80
31½"×31½"



60×60
24"×24"



30×60
12"×24"



17,5×20,5
6⅞"×8⅛"



1

Superfici
Surfaces
Oberflächen
Surfaces

Naturale

i

Effetto Cemento
Cement Look
Beton Optik
Effet Béton

Rivestimento
Wall Tiles
Wandfliesen
Revêtement

Pavimento
Floor Tiles
Bodenfliesen
Sol

Gres fine porcellanato
Fine porcelain stoneware
Feinsteinzeug
Grès cérame fin

Tecnologia digitale
Digital technology
Digital Technologie
Technologie numérique

Ripresa grafica tra le diverse lastre rettificata contenuta entro le tolleranze previste dalla norma. Per un corretto allineamento si consiglia di utilizzare una fuga di 2 mm.
Graphic representation between the rectified tiles is contained within the tolerances provided by the standard. For a correct alignment it is recommended to use a 2 mm joint.
Graphische Darstellung zwischen den verschiedenen rektifizierten Platten innerhalb der in der Norm vorgesehenen Toleranzen. Für eine korrekte Anpassung wird eine Fuge von 2mm empfohlen.
Reproduction graphique entre les différents carreaux rectifiés dans les limites des tolérances prévues par la norme. Pour un alignement correct, il est recommandé d'utiliser joints de 2 mm.



Noon



60x120
02289A | Shades Noon Nat/Ret



80x80
03862 | Shades Noon Nat/Ret



60x60
02273A | Shades Noon Nat/Ret



60x60
02278A | Shades Wash Noon Nat/Ret

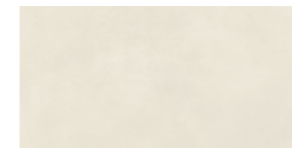

30x60
02251A | Shades Noon Nat/Ret



30x60
02256A | Shades Wash Noon Nat/Ret



17,5x20,5
02464 | Shades Noon Nat



17,5x20,5
02459 | Shades Blot Noon Nat

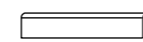



Dawn



60x120
02291A | Shades Dawn Nat/Ret



80x80
03863 | Shades Dawn Nat/Ret



60x60
02274A | Shades Dawn Nat/Ret



60x60
02279A | Shades Wash Dawn Nat/Ret



30x60
02252A | Shades Dawn Nat/Ret



30x60
02257A | Shades Wash Dawn Nat/Ret



17,5x20,5
02465 | Shades Dawn Nat



17,5x20,5
02460 | Shades Blot Dawn Nat

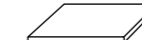
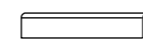



Dusk



60x120
02292A | Shades Dusk Nat/Ret



80x80
03864 | Shades Dusk Nat/Ret



60x60
02275A | Shades Dusk Nat/Ret



60x60
02281A | Shades Wash Dusk Nat/Ret



30x60
02253A | Shades Dusk Nat/Ret



30x60
02258A | Shades Wash Dusk Nat/Ret



17,5x20,5
02466 | Shades Dusk Nat



17,5x20,5
02461 | Shades Blot Dusk Nat

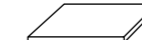
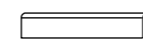



Evening



60x120
02293A | Shades Evening Nat/Ret



80x80
03865 | Shades Evening Nat/Ret



60x60
02276A | Shades Evening Nat/Ret



60x60
02282A | Shades Wash Evening Nat/Ret



30x60
02254A | Shades Evening Nat/Ret



30x60
02259A | Shades Wash Evening Nat/Ret



17,5x20,5
02467 | Shades Evening Nat



17,5x20,5
02462 | Shades Blot Evening Nat

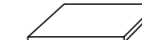
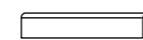

Night



60x120

02294A | Shades Night Nat/Ret



80x80

03866 | Shades Night Nat/Ret

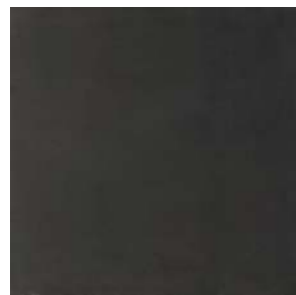

60x60

02277A | Shades Night Nat/Ret



60x60

02283A | Shades Wash Night Nat/Ret



30x60

02255A | Shades Night Nat/Ret



30x60

02261A | Shades Wash Night Nat/Ret



17,5x20,5

02468 | Shades Night Nat



17,5x20,5

02463 | Shades Blot Night Nat

Imballi

Packing
Verpackung
Emballage

Formati Sizes		± MM	Pezzi Scatola Pieces/Box Stck/Karton Carreaux/Boîte	Mq/Scatola Sqmt/Box Qm/Karton M2/Boîte	Kg/Scatola Kgs/Box Kg/Karton Kg/Boîte	Scatole/Paletta Boxes/Pallet Karton/Palette Boîte/Palette	Mq/Paletta Sqmt/Pallet Qm/Pallet M2/Palette	Kg/Paletta Kgs/Pallet Kg/Pallet Kg/Palette	Formato Paletta Size Pallet Format Pallet Dim. Palette
60x120 (24"x48") Nat/Ret	P	9,5	2	1,44	31	30	43,20	930	122x82x75
80x80 (31½"x31½") Nat/Ret	P	9,5	2	1,280	27,50	50	64,00	1375	122x80x96
60x60 (24"x24") Nat/Ret	P	9,5	4	1,44	29	32	46,08	928	120x80x75
30x60 (12"x24") Nat/Ret	P	9,5	7	1,26	25,30	40	50,40	1012	120x80x75
17,5x20,5 (6¾"x8¼") Nat	P	8,5	37	1,000	18,00	60	60,00	1080	120x80x75
Pezzi Speciali / Special Pieces									
30x120 (12"x48") Step Nat/Ret	P	9,5	3	1,080	24,00	20	-	-	-
6,5x120 (2½"x48") Battiscopa Nat/Ret	P	9,5	8	0,624	12,50	48	-	-	-
8x80 (3¼"x31½") Battiscopa Nat/Ret	P	9,5	7	0,448	11,00	65	-	-	-
4,5x60 (1¾"x24") Battiscopa Nat/Ret	P	9,5	14	0,378	8,00	80	-	-	-

Riepilogo Gamma

Collection
Serie
Gamme

Formati Sizes									Pezzi Speciali Special Pieces							
	60x120 24"x48"	80x80 31½"x31½"	60x60 24"x24"	Wash 60x60 24"x24"	30x60 12"x24"	Wash 30x60 12"x24"	17,5x20,5 6¾"x8¼"	Blot 17,5x20,5 6¾"x8¼"	Battiscopa 6,5x120 2½"x48"	Battiscopa 8x80 3¼"x31½"	Battiscopa 4,5x60 1¾"x24"	Step 30x120 12"x48"				
	± 9,5	± 9,5	± 9,5	± 9,5	± 9,5	± 9,5	± 8,5	± 8,5	DIN 51130	DIN 51097	DCOF	± 9,5	± 9,5	± 9,5	± 9,5	
Nat							02464	02459	V2	R9	A	>0.42				
	Nat/Ret	02289A	03862	02273A	02278A	02251A	02256A							02412A	02417	02407
Noon							02465	02460	V2	R9	A	>0.42				
	Nat/Ret	02291A	03863	02274A	02279A	02252A	02257A							02413A	02418	02408
Dawn							02466	02461	V2	R9	A	>0.42				
	Nat/Ret	02292A	03864	02275A	02281A	02253A	02258A							02414A	02419	02409
Dusk							02467	02462	V2	R9	A	>0.42				
	Nat/Ret	02293A	03865	02276A	02282A	02254A	02259A							02415A	02421	02410
Evening							02468	02463	V2	R9	A	>0.42				
	Nat/Ret	02294A	03866	02277A	02283A	02255A	02261A							02416A	02422	02411
Night									V2	R9	A	>0.42				
	Nat/Ret	02294A	03866	02277A	02283A	02255A	02261A							02416A	02422	02411

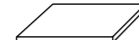
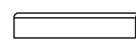

Urban

Una linea attuale dall'inconfondibile fascino metropolitano. Urban arreda con stile e originalità gli spazi del vivere contemporaneo.

A modern line with an unmistakable metropolitan appeal. Urban furnishes contemporary living areas with style and originality.

Eine aktuelle Linie mit dem besonderen Flair der Großstadt. Urban gestaltet die Lebensräume von heute originell und stilvoll.

Une ligne actuelle au charme métropolitain incomparable. Urban habille avec style et originalité les espaces de la vie contemporaine.

5

Colori
Colours
Farben
Couleurs

Bianco



Sabbia

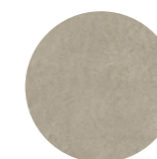

Terra

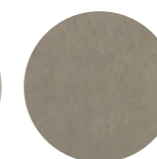

Grigio

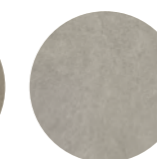

Nero

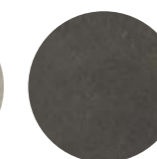

2

Formati
Sizes
Formate
Formats

60×60
24"×24"



30×60
12"×24"



2

Superfici
Surfaces
Oberflächen
Surfaces

Naturale

Grip

1

Strutture 3D
3D structures
Strukturen
Decorations and relief

Ciottoli



i

Effetto Cemento
Cement Look
Beton Optik
Effet Béton

Rivestimento
Wall Tiles
Wandfliesen
Revêtement

Pavimento
Floor Tiles
Bodenfliesen
Sol

Gres fine porcellanato ad impasto colorato
Coloured-body fine porcelain stoneware
Feinsteinzeug aus farbiger Masse
Grès cérame fin à pâte colorée

Tecnologia digitale
Digital technology
Digital Technologie
Technologie numérique



Bianco



60x60
34220A | Urban Bianco Nat/Ret



30x60
34320A | Urban Bianco Nat/Ret



30x60
35610A | Ciottoli Bi/Sa/Te Nat/Ret



30x30
00308 | Urban Mosaico Bianco Nat/Ret

Sabbia

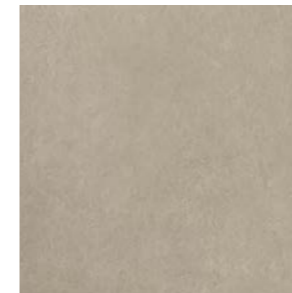

60x60
34230A | Urban Sabbia Nat/Ret
01713A | Urban Sabbia Grip/Ret \pm 20mm



30x60
35480A | Urban Sabbia Nat/Ret



30x60
35610A | Ciottoli Bi/Sa/Te Nat/Ret



30x30
00309 | Urban Mosaico Sabbia Nat/Ret



Terra



60x60
34240A | Urban Terra Nat/Ret
01714A | Urban Terra Grip/Ret \pm 20mm

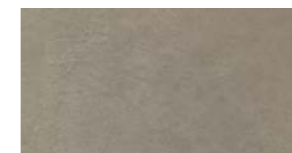

30x60
35490A | Urban Terra Nat/Ret



30x60
35610A | Ciottoli Bi/Sa/Te Nat/Ret



30x30
00311 | Urban Mosaico Terra Nat/Ret



Grigio



60x60

34250A | Urban Grigio Nat/Ret
01715A | Urban Grigio Grip/Ret ± 20mm



30x60

35590A | Urban Grigio Nat/Ret

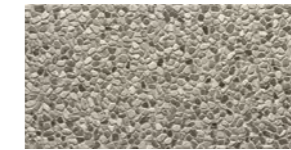

30x60

36040A | Ciottoli Ne/Gri/Te Nat/Ret



30x30

00312 | Urban Mosaico Grigio Nat/Ret

Nero



60x60

34260A | Urban Nero Nat/Ret



30x60

35600A | Urban Nero Nat/Ret

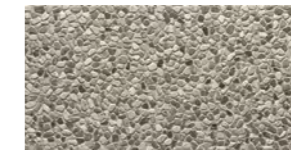

30x60

36040A | Ciottoli Ne/Gri/Te Nat/Ret



30x30

00313 | Urban Mosaico Nero Nat/Ret



Packing
Verpackung
Emballage

Formati Sizes	P	± MM							
			Pezzi Scatola Pieces/Box Stck/Karton Carreaux/Boite	Mq/Scatola Sqmt/Box Qm/Karton M2/Boite	Kg/Scatola Kgs/Box Kg/Karton Kg/Boite	Scatole/Paletta Boxes/Pallet Karton/Palette Boite/Palette	Mq/Paletta Sqmt/Pallet Qm/Pallet M2/Palette	Kg/Paletta Kgs/Pallet Kg/Pallet Kg/Palette	Formato Paletta Size Pallet Format Pallet Dim. Palette
60*60 Nat/Ret	P	9,5	4	1,44	29	32	46,08	928	120*80*75
60*60 Grip/Ret	P	20	2	0,720	32,00	32	23,04	1024	120*80*75
30*60 Nat/Ret	P	9,5	7	1,26	25,30	40	50,40	1012	120*80*75
30*60 Ciottoli Nat/Ret	P	9,5	7	1,26	25,30	32	40,32	809,6	120*80*75
30*30 Mosaico (su rete)	P	9,5	5	0,45	8	60			
Pezzi Speciali / Special Pieces									
30*60 Gradone	P	20	2	0,36	17,00	36	-	-	-
30*60 Elemento L	P	20	2	0,36	17,00	30	-	-	-
18*60 Griglia scolo	P	20	1	0,108	5,00	48	-	-	-
8*60 Battiscopa Nat/Ret	P	9,5	10	0,48	11,00	72	-	-	-

Collection
Serie
Gamme

Formati Sizes	P	± MM	 60*60 24"*24" 60*60 24"*24" 30*60 12"*24"			PEI	DIN 51130	DIN 51097	DCOF	Strutture 3D 3D Structures		Pezzi Speciali Special Pieces			
			 Ciottoli 30*60 12"*24"	 Mosaico 30*30 su rete 12"*12" (2"*2" Dot)	 Battiscopa 8*60 3 1/4"*24"					 Gradone 30*60 12*24"	 Elemento L 30*60 12"*24"	 Griglia Scolo 18*60 7 1/4"*24"			
Bianco	Nat/Ret	34220A		34320A	V2	V			>0.42	 9,5	 9,5	 9,5	 20	 20	 20
Sabbia	Nat/Ret	34230A		35480A	V2	V			>0.42		00308	00216			
	Grip/Ret		01713A					R11	A+B+C	>0.42				00562	00559
Terra	Nat/Ret	34240A		35490A	V2	V			>0.42		00311	00218			
	Grip/Ret		01714A					R11	A+B+C	>0.42				00563	00560
Grigio	Nat/Ret	34250A		35590A	V2	V			>0.42		00312	00219			
	Grip/Ret		01715A					R11	A+B+C	>0.42				00564	00561
Nero	Nat/Ret	34260A		35600A	V2	IV			>0.42		00313	00220			
Ciottoli Bi-Sa-Te	Nat/Ret									35610A		Pezzi Speciali su Richiesta - Special pieces upon request Formstücke auf Anfrage - Pièces spéciales sur demande Gradone Angolare Sx/Dx 20 mm Grip/Ret 30*60 - 12"*24" ± 20			
Ciottoli Ne-Gri-Te	Nat/Ret									36040A		 Griglia Scolo Angolare Sx/Dx 20 mm Grip/Ret 18*60 - 7 1/4"*24" ± 20			



MARBLE EFFECT

Effetto Marmo / Marmoroptik / Effet Marbre



CLICK



- 184 [Majestic Onyx](#) PREMIUM /
- 198 [Majestic Pure Selection](#) PREMIUM /
- 210 [Majestic](#) PREMIUM /
- 230 [Opulence](#) PREMIUM /
- 236 [Elegance](#) FLOOR AND MORE

Majestic Onyx

Pregiato e delicato al tempo stesso, traslucido e cromaticamente perfetto grazie alle sue sfumature. Grandi qualità dell'onice reinterpretate e perfezionate per rendere la Majestic Onyx una serie molto versatile, ideale per ambienti eleganti e contemporanei.

Both precious and delicate with its translucent and chromatically perfected nuances, Majestic Onyx is a very versatile series, ideal for elegant and contemporary environments.

Kostbar und zart zugleich, durchscheinend und chromatisch perfekt dank seiner Nuancen. Die großartigen Eigenschaften von Onyx wurden neu interpretiert und perfektioniert, um Majestic Onyx zu einer sehr vielseitigen Serie zu machen, ideal für elegante und moderne Umgebungen, in denen Farbe vorherrscht.

Précieux et délicat au même temps, translucide et chromatiquement parfait grâce à ses nuances. De grandes qualités de l'onix réinterprétées et perfectionnées pour faire de la Majestic Onyx une série très polyvalente, idéale pour les environnements élégants et contemporains où la couleur prévaut.

5

Colori
Colours
Farben
Couleurs

Pearl
White



Crystal
Beige



Smoky
Grey



Iron
Grey



Pale
Azure



3

Formati
Sizes
Formate
Formats

120×280
48"×110"



120×120
48"×48"



60×120
24"×48"



1

Superfici
Surfaces
Oberflächen
Surfaces

Levigato

i

Effetto Marmo
Marble Look
Marmoroptik
Effet Marbre

Rivestimento
Wall Tiles
Wandfliesen
Revêtement

Pavimento
Floor Tiles
Bodenfliesen
Sol

Gres fine porcellanato
Fine porcelain stoneware
Feinsteinzeug
Grès cérame fin

Tecnologia digitale
Digital technology
Digital technologie
Technologie numérique



Pearl White



120x280
05456 | Majestic Onyx Pearl White Lev/Ret



60x120
05447 | Majestic Onyx Pearl White Lev/Ret



120x120
05452 | Majestic Onyx Pearl White Lev/Ret

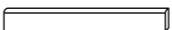



Crystal Beige



120x280
05458 | Majestic Onyx Crystal Beige Lev/Ret



60x120
05449 | Majestic Onyx Crystal Beige Lev/Ret



120x120
05454 | Majestic Onyx Crystal Beige Lev/Ret

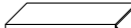



Smoky Grey



120x280
05457 | Majestic Onyx Smoky Grey Lev/Ret



60x120
05448 | Majestic Onyx Smoky Grey Lev/Ret



120x120
05453 | Majestic Onyx Smoky Grey Lev/Ret



Iron Grey



120x280
05537 | Majestic Onyx Iron Grey Lev/Ret



60x120
05535 | Majestic Onyx Iron Grey Lev/Ret



120x120
05536 | Majestic Onyx Iron Grey Lev/Ret



Pale Azure



120x280
05459 | Majestic Onyx Pale Azure Lev/Ret









60x120
05451 | Majestic Onyx Pale Azure Lev/Ret



120x120
05455 | Majestic Onyx Pale Azure Lev/Ret

Imballi

Packing
Verpackung
Emballage







Formati Sizes		± MM	 Pezzi Scatola Pieces/Box Stck/Karton Carreaux/Boite	 Mq/Scatola Sqmt/Box Qm/Karton M2/Boite	 Kg/Scatola Kgs/Box Kg/Karton Kg/Boite	 Scatole/Paletta Boxes/Pallet Karton/Palette Boite/Palette	 Mq/Paletta Sqmt/Pallet Qm/Pallet M2/Palette	 Kg/Paletta Kgs/Pallet Kg/Pallet Kg/Palette	 Formato Paletta Size Pallet Format Pallet Dim. Palette
120x280 (48"x110") Lev/Ret	P	6	1	3,36	46,50	20	67,20	930	143x294x35
120x120 (48"x48") Lev/Ret	P	8,5	2	2,88	56,00	24	69,12	1344	135x122x68
60x120 (24"x48") Lev/Ret	P	8,5	2	1,44	29,00	36	51,84	1044	122x82x75
Pezzi Speciali / Special Pieces									
33x120 (13"x48") Gradino Costa Retta Lev/Ret	P	8,5	2	0,792	16,00	20	-	-	-
4,5x120 (1 1/4"x48") Battiscopa Lev/Ret	P	8,5	6	0,324	6,10	48	-	-	-

Riepilogo Gamma

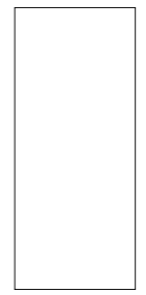
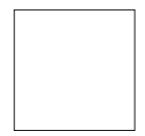
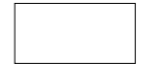
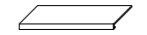
Collection
Serie
Gamme

CLICK

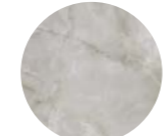
PDF Merchandising

	Formati Sizes	Pezzi Speciali Special Pieces					
							
		120x280 48"x110"	120x120 48"x48"	60x120 24"x48"	Gradino Costa Retta 33x120 - 13"x48"	Battiscopa 4,5x120 - 1 1/4"x48"	
		± 6	± 8,5	± 8,5	± 8,5	± 8,5	
 Pearl White	Lev/Ret	05456	05452	05447	05465	05461	V1
 Crystal Beige	Lev/Ret	05458	05454	05449	05467	05463	V1
 Smoky Grey	Lev/Ret	05457	05453	05448	05466	05462	V1
 Iron Grey	Lev/Ret	05537	05536	05535	05539	05538	V1
 Pale Azure	Lev/Ret	05459	05455	05451	05468	05464	V1

Majestic Pure Selection

Il fascino e l'eleganza del candore marmoreo italiano rivivono sulle superfici ceramiche di Majestic Pure Selection. La speciale selezione di pregiati marmi Majestic in cui tutta la purezza del bianco viene esaltata dalle quattro trame nobili delle venature italiane più belle e ricercate, come Calacatta, Statuario, Arabescato e Dolomiti.

The allure and elegance of Italian white marble is reproduced on the ceramic surfaces of Majestic Pure Selection. The special selection of fine Majestic marbles in which all the purity of white is enhanced by the four elegant patterns of the most beautiful and sought-after Italian veining, Calacatta, Statuario, Arabescato and Dolomiti.

Der Charme und die Eleganz des reinweißen italienischen Marmors erwecken sich auf den Keramikoberflächen von Majestic Pure Selection. Die Reinheit der Weißsteine wird durch edle Zeichnung der vier schönsten und begehrtesten italienischen Marmore wie Calacatta, Statuario, Arabescato und Dolomiti betont.

Le charme et l'élégance de la blancheur éblouissante du marbre italien reprennent vie sur les surfaces céramiques de Majestic Pure Selection. Dans cette sélection spéciale de marbres précieux Majestic, toute la pureté du blanc est exaltée par les quatre lacs de nobles veinages italiens parmi les plus beaux et les plus recherchés : Calacatta, Statuario, Arabescato et Dolomiti.

4

Colori
Colours
Farben
Couleurs

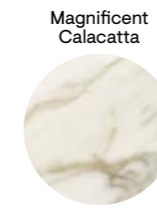
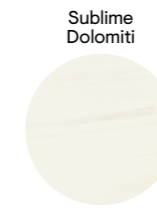
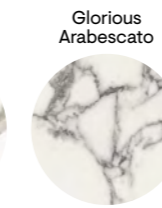

5

Formati
Sizes
Formate
Formats

120×280
48"×110"



120×120
48"×48"



60×120
24"×48"



80×80
31½"×31½"



60×60
24"×24"



2

Superfici
Surfaces
Oberflächen
Surfaces

Naturale Levigato

i

Effetto Marmo
Marble Look
Marmoroptik
Effet Marbre

Rivestimento
Wall Tiles
Wandfliesen
Revêtement

Pavimento
Floor Tiles
Bodenfliesen
Sol

Gres fine porcellanato
Fine porcelain stoneware
Feinsteinzeug
Grès cérame fin

Tecnologia digitale
Digital technology
Digital technologie
Technologie numérique

Ripresa grafica tra le diverse lastre rettificata contenuta entro le tolleranze previste dalla norma. Per un corretto allineamento si consiglia di utilizzare una fuga di 2 mm.
Graphic representation between the rectified tiles is contained within the tolerances provided by the standard. For a correct alignment it is recommended to use a 2 mm joint.
Grafische Darstellung zwischen den verschiedenen rektifizierten Platten innerhalb der in der Norm vorgesehenen Toleranzen. Für eine korrekte Anpassung wird eine Fuge von 2mm empfohlen.
Reproduction graphique entre les différents carreaux rectifiés dans les limites des tolérances prévues par la norme. Pour un alignement correct, il est recommandé d'utiliser joints de 2 mm.

▶ WATCH THE VIDEO



Gres fine porcellanato / Tecnologia digitale
 Fine porcelain stoneware / Digital technology

Feinsteinzeug / Digital Technologie
 Grès cérame fin / Technologie numérique

Marble Effect
 PREMIUM

Superb Statuario



120×280
05473 | Superb Statuario Lev/Ret



120×120
03921A | Superb Statuario Lev/Ret



60×120
03901A | Superb Statuario Nat/Ret
03905A | Superb Statuario Lev/Ret

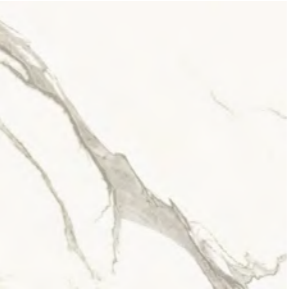

60×60
03912A | Superb Statuario Nat/Ret
03916A | Superb Statuario Lev/Ret



60×120
03909A | Foliage Nat/Ret
 (mix 6 graphics)



60×120
03908A | Grove Lev/Ret
 (mix 6 graphics)



30×30
03926 | Mosaico Superb Statuario Nat/Ret
03931 | Mosaico Superb Statuario Lev/Ret



Gres fine porcellanato / Tecnologia digitale
Fine porcelain stoneware / Digital technology

Feinsteinzeug / Digital Technologie
Grès cérame fin / Technologie numérique

Marble Effect
PREMIUM

Glorious Arabescato



120x120
03922A | Glorious Arabescato Lev/Ret



60x120
03908A | Grove Lev/Ret
(mix 6 graphics)



60x120
03909A | Foliage Nat/Ret
(mix 6 graphics)



60x120
03902A | Glorious Arabescato Nat/Ret
03906A | Glorious Arabescato Lev/Ret



30x30
03927 | Mosaico Glorious Arabescato Nat/Ret
03932 | Mosaico Glorious Arabescato Lev/Ret

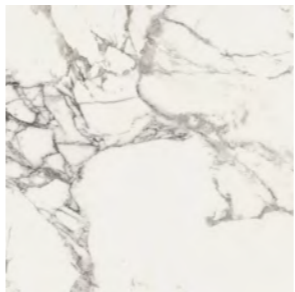

60x60
03913A | Glorious Arabescato Nat/Ret
03917A | Glorious Arabescato Lev/Ret



Sublime Dolomiti



120x120
03923A | Sublime Dolomiti Lev/Ret



60x120
03908A | Grove Lev/Ret
 (mix 6 graphics)



60x120
03909A | Foliage Nat/Ret
 (mix 6 graphics)



60x120
03903A | Sublime Dolomiti Nat/Ret
03907A | Sublime Dolomiti Lev/Ret



30x30
03928 | Mosaico Sublime Dolomiti Nat/Ret
03933 | Mosaico Sublime Dolomiti Lev/Ret



60x60
03914A | Sublime Dolomiti Nat/Ret
03918A | Sublime Dolomiti Lev/Ret



Magnificent Calacatta



120×280
05472 | Magnificent Calacatta Lev/Ret



120×120
03919A | Magnificent Calacatta Lev/Ret



60×120
03909A | Foliage Nat/Ret
(mix 6 graphics)

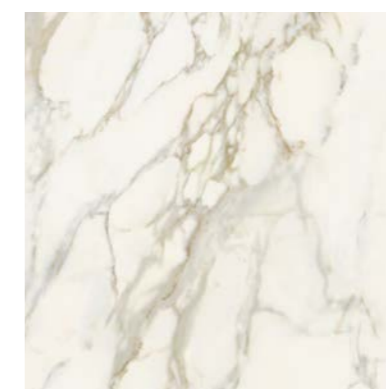

80×80
04085 | Magnificent Calacatta Lev/Ret



60×120
03908A | Grove Lev/Ret
(mix 6 graphics)

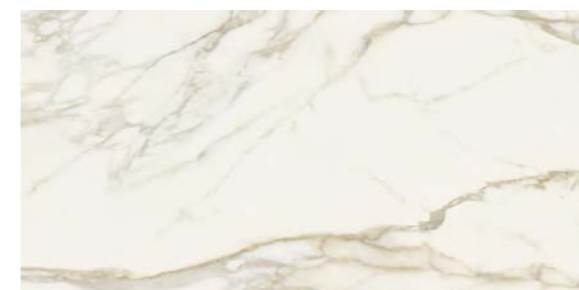

60×120
03899A | Magnificent Calacatta Nat/Ret
03904A | Magnificent Calacatta Lev/Ret

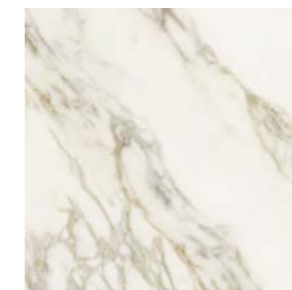







60×60
03911A | Magnificent Calacatta Nat/Ret
03915A | Magnificent Calacatta Lev/Ret



30×30
03925 | Mosaico Magnificent Calacatta Nat/Ret
03929 | Mosaico Magnificent Calacatta Lev/Ret

Imballi

Packing
Verpackung
Emballage

Formati Sizes	P	± MM							
			Pezzi Scatola Pieces/Box Stck/Karton Carreaux/Boite	Mq/Scatola Sqmt/Box Qm/Karton M2/Boite	Kg/Scatola Kgs/Box Kg/Karton Kg/Boite	Scatole/Paletta Boxes/Pallet Karton/Palette Boite/Palette	Mq/Paletta Sqmt/Pallet Qm/Pallet M2/Palette	Kg/Paletta Kgs/Pallet Kg/Pallet Kg/Palette	Formato Paletta Size Pallet Format Pallet Dim. Palette
120x280 (48"x110") Lev/Ret	P	6	1	3,36	46,50	20	67,20	930	143x294x35
120x120 (48"x48") Lev/Ret	P	9,5	2	2,88	58,00	22	63,36	1276	135x122x68
80x80 (32"x32") Lev/Ret	P	9,5	2	1,28	27,50	50	64,00	1375	122x80x96
60x120 (24"x48") Nat/Ret	P	9,5	2	1,44	31,00	30	43,20	930	122x82x75
60x120 (24"x48") Lev/Ret	P	9,5	2	1,44	32,00	30	43,20	960	122x82x75
60x60 (24"x24") Nat/Ret	P	9,5	4	1,44	29,00	32	46,08	928	120x80x75
60x60 (24"x24") Lev/Ret	P	9,5	4	1,44	30,00	32	46,08	960	120x80x75
60x120 (24"x48") Grove Lev/Ret	P		2	1,44	32,00	30	43,20	960	122x82x75
60x120 (24"x48") Foliage Nat/Ret	P		2	1,44	31,00	30	43,20	930	122x82x75
30x30 (12"x12") Mosaico Nat/Ret	P		5	0,45	8,00	60	-	-	-
30x30 (12"x12") Mosaico Lev/Ret	P		5	0,45	8,00	60	-	-	-
Pezzi Speciali / Special Pieces									
33x120 (13"x48") Gradino Costa Retta Nat/Ret - Lev/Ret	P		2	0,79	18,50	20	-	-	-
4,5x60 (1 3/4"x24") Battiscopa Nat/Ret - Lev/Ret	P		14	0,380	8,00	80	-	-	-
1,5x120 (3/4"x48") Bacchetta Lev/Ret	P		6	0,110	2,50	48	-	-	-
1,5x1,5 (3/4"x3/4") Unghia Jolly Lev/Ret	P		6	0,001	0,50	48	-	-	-

Riepilogo Gamma

CLICK

PDF Merchandising

Collection
Serie
Gamme

Formati Sizes	P	± MM	Pezzi Scatola Pieces/Box Stck/Karton Carreaux/Boite	Mq/Scatola Sqmt/Box Qm/Karton M2/Boite	Kg/Scatola Kgs/Box Kg/Karton Kg/Boite	Scatole/Paletta Boxes/Pallet Karton/Palette Boite/Palette	Mq/Paletta Sqmt/Pallet Qm/Pallet M2/Palette	Kg/Paletta Kgs/Pallet Kg/Pallet Kg/Palette	Formato Paletta Size Pallet Format Pallet Dim. Palette	Pezzi Speciali Special Pieces			
										Gradino Costa Retta 33x120 13"x48"	Battiscopa 4,5x60 1 3/4"x24"	Bacchetta Jolly 1,5x120 3/4"x48"	Unghia Jolly 1,5x1,5 3/4"x3/4"
120x280 (48"x110") Lev/Ret	P	6	1	3,36	46,50	20	67,20	930	143x294x35				
120x120 (48"x48") Lev/Ret	P	9,5	2	2,88	58,00	22	63,36	1276	135x122x68				
80x80 (32"x32") Lev/Ret	P	9,5	2	1,28	27,50	50	64,00	1375	122x80x96				
60x120 (24"x48") Nat/Ret	P	9,5	2	1,44	31,00	30	43,20	930	122x82x75				
60x120 (24"x48") Lev/Ret	P	9,5	2	1,44	32,00	30	43,20	960	122x82x75				
60x60 (24"x24") Nat/Ret	P	9,5	4	1,44	29,00	32	46,08	928	120x80x75				
60x60 (24"x24") Lev/Ret	P	9,5	4	1,44	30,00	32	46,08	960	120x80x75				
60x120 (24"x48") Grove Lev/Ret	P		2	1,44	32,00	30	43,20	960	122x82x75				
60x120 (24"x48") Foliage Nat/Ret	P		2	1,44	31,00	30	43,20	930	122x82x75				
30x30 (12"x12") Mosaico Nat/Ret	P		5	0,45	8,00	60	-	-	-				
30x30 (12"x12") Mosaico Lev/Ret	P		5	0,45	8,00	60	-	-	-				
Pezzi Speciali / Special Pieces													
33x120 (13"x48") Gradino Costa Retta Nat/Ret - Lev/Ret	P		2	0,79	18,50	20	-	-	-				
4,5x60 (1 3/4"x24") Battiscopa Nat/Ret - Lev/Ret	P		14	0,380	8,00	80	-	-	-				
1,5x120 (3/4"x48") Bacchetta Lev/Ret	P		6	0,110	2,50	48	-	-	-				
1,5x1,5 (3/4"x3/4") Unghia Jolly Lev/Ret	P		6	0,001	0,50	48	-	-	-				

Majestic

La ricerca stilistica della collezione Majestic esce volutamente dagli schemi classici di utilizzo delle superfici effetto marmo, per vestire spazi residenziali e commerciali con uno stile eclettico e lussuoso.

The stylistic research of the Majestic collection deliberately goes beyond the classic patterns of use of marble-effect surfaces, to dress residential and commercial spaces with an eclectic and luxurious style.

Die stilistischen Recherchen der Kollektion Majestic gehen mit Absicht über die herkömmlichen Verwendungsmöglichkeiten der Oberflächen mit Marmoroptik hinaus, um Wohn- und Gewerbebereiche in eklektischem, luxuriösem Stil zu verkleiden.

La recherche stylistique de la collection Majestic sort volontairement des sentiers battus de l'utilisation du marbre en céramique, pour revêtir des surfaces résidentielles et commerciales avec un style éclectique et luxueux.

7

Colori
Colours
Farben
Couleurs

Apuanian White



Queen's Tiara



Imperial Pearl



Precious Gem



Supreme Grey

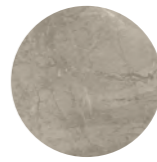

Lime Black



Royal Nero



5

Formati
Sizes
Formate
Formats

120×280
48"×110"



120×120
48"×48"



60×120
24"×48"



80×80
31½"×31½"



60×60
24"×24"



2

Superfici
Surfaces
Oberflächen
Surfaces

Naturale

Levigato

i

Effetto Marmo
Marble Look
Marmoroptik
Effet Marbre

Rivestimento
Wall Tiles
Wandfliesen
Revêtement

Pavimento
Floor Tiles
Bodenfliesen
Sol

Gres fine porcellanato
Fine porcelain stoneware
Feinsteinzeug
Grès cérame fin

Tecnologia digitale
Digital technology
Digital Technologie
Technologie numérique

Ripresa grafica tra le diverse lastre rettificata contenuta entro le tolleranze previste dalla norma. Per un corretto allineamento si consiglia di utilizzare una fuga di 2 mm.
Graphic representation between the rectified tiles is contained within the tolerances provided by the standard. For a correct alignment it is recommended to use a 2 mm joint.
Grafische Darstellung zwischen den verschiedenen rektifizierten Platten innerhalb der in der Norm vorgesehenen Toleranzen. Für eine korrekte Anpassung wird eine Fuge von 2mm empfohlen.
Reproduction graphique entre les différents carreaux rectifiés dans les limites des tolérances prévues par la norme. Pour un alignement correct, il est recommandé d'utiliser joints de 2 mm.



Apuanian White



120x120
02587A | Apuanian White Lev/Ret



60x120
***02628A** | Majestic Abbey Road A Ret
60x120
***02629A** | Majestic Abbey Road B Ret

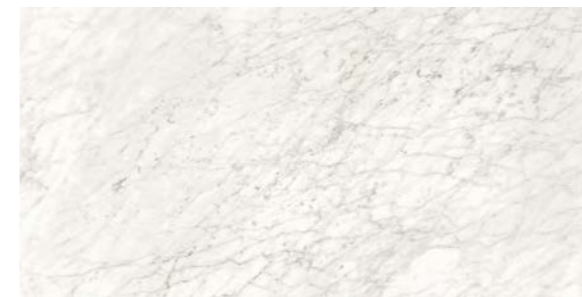

60x120
02582A | Apuanian White Nat/Ret
02576A | Apuanian White Lev/Ret

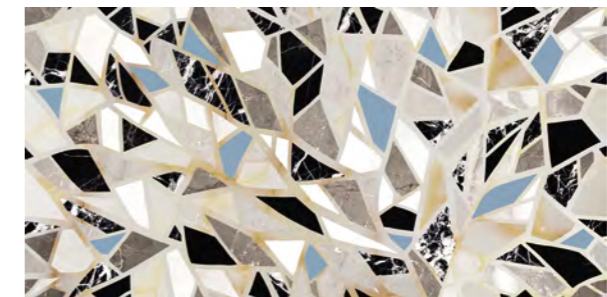

60x120
02599A | Majestic Mix Art Lev/Ret (Mix 2 Different Decors)

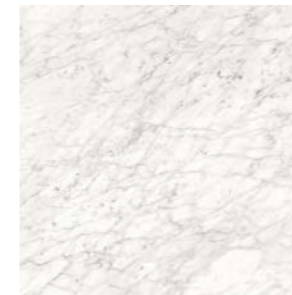

60x60
02569A | Apuanian White Nat/Ret
02563A | Apuanian White Lev/Ret



34x36
02615 | Hexagon Apuanian White Lev

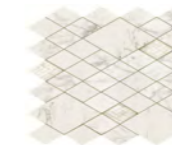

31x35
02622 | Majestic Net Apuanian White Lev

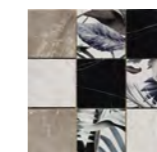

30x30
***02632** | Mosaico Jungle Cold Lev



30x30
02645 | Cube Apuanian White Nat



28x32,5
02634 | Majestic Arrows Cold Lev

*Decori realizzati con smalti e metalli preziosi. Vedere nota a pag. 366-367
Decors made with glazes and precious metals. See note on pages 366-367
Dekore aus Glasuren und Edelmetallen. Siehe Hinweis auf Seiten 366-367
Décors réalisés avec des émaux et des métaux précieux. Voir note aux pages 366-367

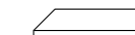



Queen's Tiara

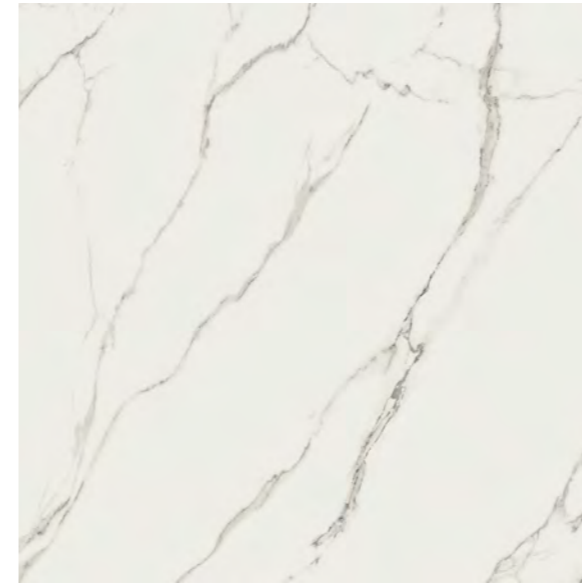

120x120
05304 | Queen's Tiara Lev/Ret



60x120
***02627A** | Majestic Jungle Cold Lev/Ret
(Mix 2 Different Decors)

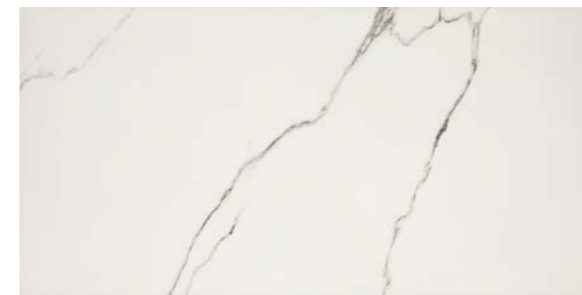

60x120
02656A | Queen's Tiara Nat/Ret
02651A | Queen's Tiara Lev/Ret

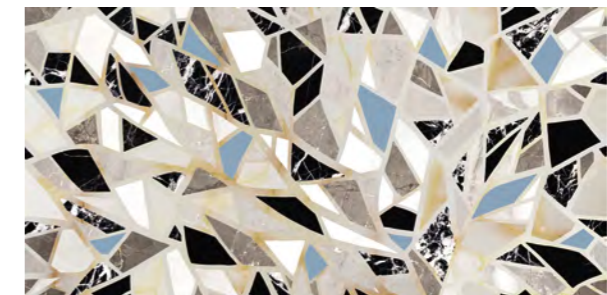

60x120
02599A | Majestic Mix Art Lev/Ret
(Mix 2 Different Decors)

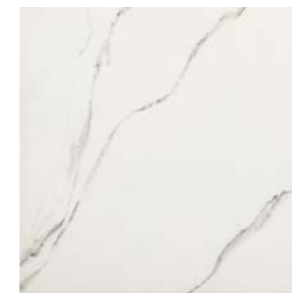

60x60
02655A | Queen's Tiara Nat/Ret
02652A | Queen's Tiara Lev/Ret



34x36
02660 | Hexagon
Queen's Tiara Lev

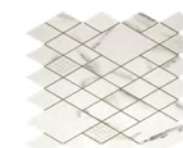

31x35
02661 | Majestic Net
Queen's Tiara Lev

*Decori realizzati con smalti e metalli preziosi. Vedere nota a pag. 366-367
Decors made with glazes and precious metals. See note on pages 366-367
Dekore aus Glasuren und Edelmetallen. Siehe Hinweis auf Seiten 366-367
Décors réalisés avec des émaux et des métaux précieux. Voir note aux pages 366-367

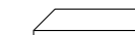



Imperial Pearl



60x120
02584A | Imperial Pearl Nat/Ret
02578A | Imperial Pearl Lev/Ret



60x60
02572A | Imperial Pearl Nat/Ret
02565A | Imperial Pearl Lev/Ret



34x36
02617 | Hexagon
Imperial Pearl Lev

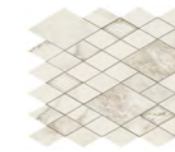

31x35
02624 | Majestic Net
Imperial Pearl Lev

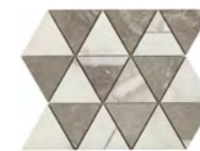

28x32,5
02633 | Majestic Arrows
Warm Lev

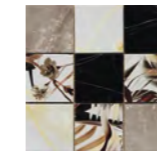

30x30
***02631** | Mosaico
Jungle Warm Lev



60x120
***02626A** | Majestic Jungle Warm Lev/Ret
(Mix 2 Different Decors)



60x120
02599A | Majestic Mix Art Lev/Ret
(Mix 2 Different Decors)

*Decori realizzati con smalti e metalli preziosi. Vedere nota a pag. 366-367
Decors made with glazes and precious metals. See note on pages 366-367
Dekore aus Glasuren und Edelmetallen. Siehe Hinweis auf Seiten 366-367
Décors réalisés avec des émaux et des métaux précieux. Voir note aux pages 366-367

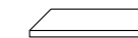
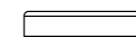



Precious Gem



60x120
02665A | Precious Gem Nat/Ret
02662A | Precious Gem Lev/Ret



60x120
***02626A** | Majestic Jungle Warm Lev/Ret
(Mix 2 Different Decors)



80x80
03687 | Precious Gem Lev/Ret



60x120
02599A | Majestic Mix Art Lev/Ret
(Mix 2 Different Decors)

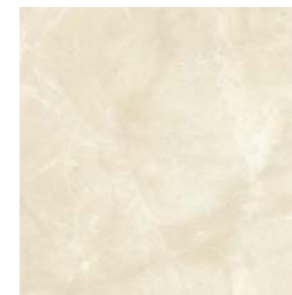

60x60
02666A | Precious Gem Nat/Ret
02663A | Precious Gem Lev/Ret



34x36
02676 | Hexagon
Precious Gem Lev

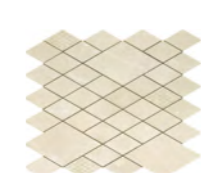

31x35
02677 | Majestic Net
Precious Gem Lev

*Decori realizzati con smalti e metalli preziosi. Vedere nota a pag. 366-367
Decors made with glazes and precious metals. See note on pages 366-367
Dekore aus Glasuren und Edelmetallen. Siehe Hinweis auf Seiten 366-367
Décors réalisés avec des émaux et des métaux précieux. Voir note aux pages 366-367

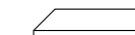



Supreme Grey



120x120
02588A | Supreme Grey Lev/Ret



60x120
02585A | Supreme Grey Nat/Ret
02579A | Supreme Grey Lev/Ret



60x60
02573A | Supreme Grey Nat/Ret
02566A | Supreme Grey Lev/Ret



60x120
***02626A** | Majestic Jungle Warm Lev/Ret
(Mix 2 Different Decors)



60x120
02599A | Majestic Mix Art Lev/Ret
(Mix 2 Different Decors)

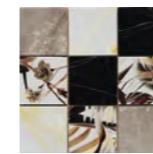

30x30
***02631** | Mosaico
Jungle Warm Lev



30x30
02647 | Cube
Supreme Grey Nat



34x36
02618 | Hexagon
Supreme Grey Lev

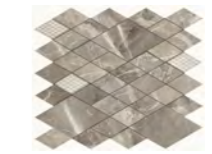

31x35
02625 | Majestic Net
Supreme Grey Lev

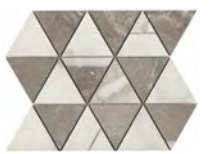

28x32,5
02633 | Majestic Arrows
Warm Lev

*Decori realizzati con smalti e metalli preziosi. Vedere nota a pag. 366-367
Decors made with glazes and precious metals. See note on pages 366-367
Dekore aus Glasuren und Edelmetallen. Siehe Hinweis auf Seiten 366-367
Décors réalisés avec des émaux et des métaux précieux. Voir note aux pages 366-367

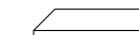



Lime Black



120x280
05488 | Lime Black Lev/Ret



120x120
05594 | Lime Black Lev/Ret



60x120
05595 | Lime Black Lev/Ret



Royal Nero



60x120
02580A | Royal Nero Nat/Ret
02574A | Royal Nero Lev/Ret



60x120
*02628A | Majestic Abbey
Road A Ret

60x120
*02629A | Majestic Abbey
Road B Ret

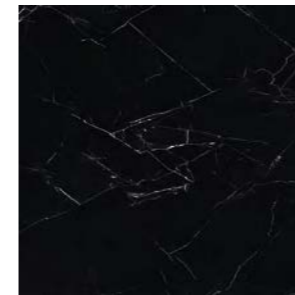

60x60
02567A | Royal Nero Nat/Ret
02561A | Royal Nero Lev/Ret



7,5x30
02643 | Brick Royal
Nero Nat/Ret

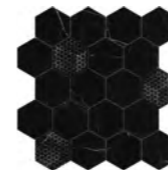

34x36
02613 | Hexagon
Royal Nero Lev

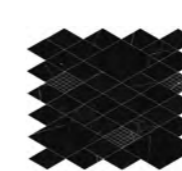

31x35
02619 | Majestic Net
Royal Nero Lev

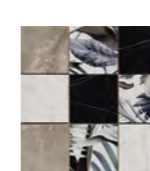

30x30
*02632 | Mosaico
Jungle Cold Lev

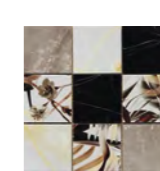

30x30
*02631 | Mosaico
Jungle Warm Lev



28x32,5
02634 | Majestic Arrows
Cold Lev



30x30
02646 | Cube Royal Nero Nat

*Decori realizzati con smalti e metalli preziosi. Vedere nota a pag. 366-367
Decors made with glazes and precious metals. See note on pages 366-367
Dekore aus Glasuren und Edelmetallen. Siehe Hinweis auf Seiten 366-367
Décors réalisés avec des émaux et des métaux précieux. Voir note aux pages 366-367

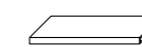
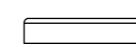

Imballi

Packing
Verpackung
Emballage

Formati Sizes	P	± MM							
			Pezzi Scatola Pieces/Box Stck/Karton Carreaux/Boîte	Mq/Scatola Sqmt/Box Qm/Karton M2/Boîte	Kg/Scatola Kgs/Box Kg/Karton Kg/Boîte	Scatole/Paletta Boxes/Pallet Karton/Palette Boîte/Palette	Mq/Paletta Sqmt/Pallet Qm/Pallet M2/Palette	Kg/Paletta Kgs/Pallet Kg/Pallet Kg/Palette	Formato Paletta Size Pallet Format Pallet Dim. Palette
120x280 (48"x110") Lev/Ret	P	6	1	3,36	46,50	20	67,20	930	143x294x35
120x120 (48"x48") Lev/Ret	P	9,5 8,5	2 2	2,88 2,88	58,00 56,00	22 24	63,36 69,12	1276 1344	135x122x68
80x80 (32"x32") Lev/Ret	P	9,5	2	1,28	27,50	50	64,00	1375	122x80x96
60x120 (24"x48") Nat/Ret	P	9,5	2	1,44	31,00	30	43,20	930	122x82x75
60x120 (24"x48") Lev/Ret	P	9,5 8,5	2 2	1,44 1,44	32,00 29,00	30 36	43,20 51,84	960 1044	122x82x75
60x60 (24"x24") Nat/Ret	P	9,5	4	1,44	29,00	32	46,08	928	120x80x75
60x60 (24"x24") Lev/Ret	P	9,5	4	1,44	30,00	32	46,08	960	120x80x75
60x120 (24"x48") Mix Art Lev/Ret	P		2	1,44	32,00	30	43,20	960	122x82x75
60x120 (24"x48") Abbey Road Nat/Ret	P		2	1,44	32,00	15	21,60	480	122x82x75
60x120 (24"x48") Jungle Lev/Ret	P		2	1,44	32,00	15	21,60	480	122x82x75
7,5x30 (3"x12") Brick Nat/Ret	P		22	0,50	10,50	96	-	-	-
34x36 (13¼"x14¼") Hexagon Lev/Ret	P		6	0,73	15,30	40	-	-	-
28x32,5 (11"x12¾") Arrows Lev/Ret	P		6	0,55	11,50	54	-	-	-
31x35 (11½"x13¼") Net Lev/Ret	P		6	0,65	13,56	40	-	-	-
30x30 (12"x12") Cube Nat/Ret	P		5	0,45	8,00	54	-	-	-
30x30 (12"x12") Mosaico Jungle Lev/Ret	P		6	0,54	10,20	54	-	-	-
Pezzi Speciali / Special Pieces									
33x120 (13"x48") Gradino Costa Retta Nat/Ret - Lev/Ret	P		2	0,79	18,50	20	-	-	-
8x60 (3¼"x24") Battiscopa Nat/Ret - Lev/Ret	P		10	0,480	11,00	72	-	-	-
6,5x120 (1½"x48") Battiscopa Nat/Ret - Lev/Ret	P		8	0,620	14,00	48	-	-	-

Riepilogo Gamma

Collection
Serie
Gamme

Formati Sizes	P	± MM	Pezzi Scatola Pieces/Box Stck/Karton Carreaux/Boîte	Mq/Scatola Sqmt/Box Qm/Karton M2/Boîte	Kg/Scatola Kgs/Box Kg/Karton Kg/Boîte	Scatole/Paletta Boxes/Pallet Karton/Palette Boîte/Palette	Mq/Paletta Sqmt/Pallet Qm/Pallet M2/Palette	Kg/Paletta Kgs/Pallet Kg/Pallet Kg/Palette	Formato Paletta Size Pallet Format Pallet Dim. Palette	PEI	DIN 51130	DIN 51097	DCOF	 Mix Art 60x120 24"x48"	 Abbey Road A Abbey Road B 60x120 24"x48"	 Jungle 60x120 24"x48"	
																	120x280 48"x110"
Apuanian White	Nat/Ret									V4	V	R9	A	> 0,42		O2628A O2629A	
Lev/Ret															O2599A		O2627A
Queen's Tiara	Nat/Ret									V4	V	R9	A	> 0,42			
Lev/Ret															O2599A		O2627A
Imperial Pearl	Nat/Ret									V4	V	R9	A	> 0,42			
Lev/Ret															O2599A		O2626A
Precious Gem	Nat/Ret									V4	V	R9	A	> 0,42			
Lev/Ret															O2599A		O2626A
Supreme Grey	Nat/Ret									V4	V	R9	A	> 0,42			
Lev/Ret															O2599A		O2626A
Lime Black	Nat/Ret									V4	IV	R9	A	> 0,42			
Lev/Ret															O2599A		O2626A O2627A
Royal Nero	Nat/Ret									V4	IV	R9	A	> 0,42		O2628A O2629A	
Lev/Ret															O2599A		O2626A O2627A

Collection
Serie
Gamme

	Formati Sizes						
		Brick 7,5×30 3"×12"	Hexagon 34×36 13 ^{3/8} "×14 ^{1/8} "	Arrows 28×32,5 11"×12 ^{3/4} "	Net 31×35 12 ^{1/4} "×13 ^{3/4} "	Cube 30×30 12"×12"	Mos. Jungle 30×30 12"×12"
	Nat/Ret	02642				02645	
Apuanian White	Lev/Ret		02615	02634	02622		02632
	Nat/Ret						
Queen's Tiara	Lev/Ret		02660		02661		
	Nat/Ret						
Imperial Pearl	Lev/Ret		02617	02633	02624		02631
	Nat/Ret						
Precious Gem	Lev/Ret		02676		02677		
	Nat/Ret	02644				02647	
Supreme Grey	Lev/Ret		02618	02633	02625		02631
	Nat/Ret						
Lime Black	Lev/Ret						
	Nat/Ret	02643				02646	
Royal Nero	Lev/Ret		02613	02634	02619		02632 02631

Collection
Serie
Gamme

	Formati Sizes				
		Gradino Costa Retta 33×120 13"×48"	Battiscopa 8×60 3 ^{1/8} "×24"	Battiscopa 6,5×120 2 ^{1/2} "×48"	
	Nat/Ret	02760A	02712	02728A	V4
Apuanian White	Lev/Ret	02752A	02704	02720A	
	Nat/Ret	02764A	02716	02732A	V4
Queen's Tiara	Lev/Ret	03739A	02708	02724A	
	Nat/Ret	02762A	02714	02730A	V4
Imperial Pearl	Lev/Ret	02754A	02706	02722A	
	Nat/Ret	02765A	02717	02733A	V4
Precious Gem	Lev/Ret	03741A	02709	02725A	
	Nat/Ret	02763A	02715	02731A	V4
Supreme Grey	Lev/Ret	03738A	02707	02723A	
	Nat/Ret				V4
Lime Black	Lev/Ret	05635		05636	
	Nat/Ret	02758A	02710	02726A	V4
Royal Nero	Lev/Ret	02750A	02702	02718A	

Opulence

Il team di ricerca Ceramiche Piemme, costantemente impegnato nell'innovazione di prodotto, ha realizzato un progetto esclusivo e ben articolato, declinandolo in cinque eleganti essenze, per donare agli ambienti tutta l'inconfondibile personalità dello stile Ceramiche Piemme.

The Ceramiche Piemme research team, constantly engaged in product innovation, has worked to create an exclusive and highly structured design featuring five elegant colours in order to characterise the environments with unmistakable personality of the Ceramiche Piemme style.

Entwicklungsteam von Ceramiche Piemme nun ein exquisites, ausgefeiltes Konzept vorgelegt, das fünf elegante Gesteine umfasst, herstellt im Einbrandverfahren, zur Seite gestellt werden. Damit bietet es alle Voraussetzungen für ausdrucksstarke Raumgestaltungen im Stil von Ceramiche Piemme.

Axée en permanence sur l'innovation de produit, l'équipe de recherche Ceramiche Piemme a examiné les tendances pour mettre au point un projet exclusif et complet. Elle l'a décliné en cinq colorations élégantes pour flanquer les espaces de toute l'extraordinaire personnalité du style Ceramiche Piemme.

5

Colori
Colours
Farben
Couleurs

Bliss



Delight



Eccentric

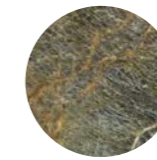

Pleasure

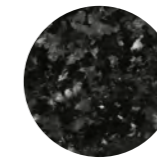

Caprice



2

Formati
Sizes
Formate
Formats

120×280
48"×110"



60×120
24"×48"



1

Superfici
Surfaces
Oberflächen
Surfaces

Levigato

i

Effetto Marmo
Marble Look
Marmoroptik
Effet Marbre

Rivestimento
Wall Tiles
Wandfliesen
Revêtement

Pavimento
Floor Tiles
Bodenfliesen
Sol

Gres fine porcellanato
Fine porcelain stoneware
Feinsteinzeug
Grès cérame fin

Tecnologia digitale
Digital technology
Digital Technologie
Technologie numérique

Ripresa grafica tra le diverse lastre rettificata contenuta entro le tolleranze previste dalla norma. Per un corretto allineamento si consiglia di utilizzare una fuga di 2 mm.
Graphic representation between the rectified tiles is contained within the tolerances provided by the standard. For a correct alignment it is recommended to use a 2 mm joint.
Grafische Darstellung zwischen den verschiedenen rektifizierten Platten innerhalb der in der Norm vorgesehenen Toleranzen. Für eine korrekte Anpassung wird eine Fuge von 2mm empfohlen.
Reproduction graphique entre les différents carreaux rectifiés dans les limites des tolérances prévues par la norme. Pour un alignement correct, il est recommandé d'utiliser joints de 2 mm.



Bliss



60x120

03346A | Opulence Bliss Lev/Ret



60x120

***03591A** | Opulence Botanic Lev/Ret



30x30

03443 | Opulence Balance Lev/Ret

Delight



60x120

03347A | Opulence Delight Lev/Ret

Pleasure

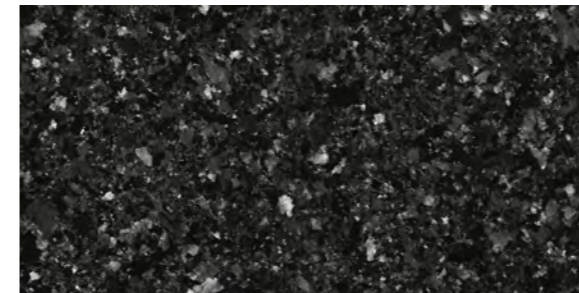

60x120

03348A | Opulence Pleasure Lev/Ret



30x30

03443 | Opulence Balance Lev/Ret

Caprice



60x120

03351A | Opulence Caprice Lev/Ret

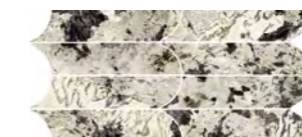

25x50

03445 | Opulence Illusion Lev/Ret

* Decori realizzati con smalti e metalli preziosi. Vedere nota a pag. 366-367
Decors made with glazes and precious metals. See note on pages 366-367
Dekore aus Glasuren und Edelmetallen. Siehe Hinweis auf Seiten 366-367
Décors réalisés avec des émaux et des métaux précieux. Voir note aux pages 366-367



Eccentric

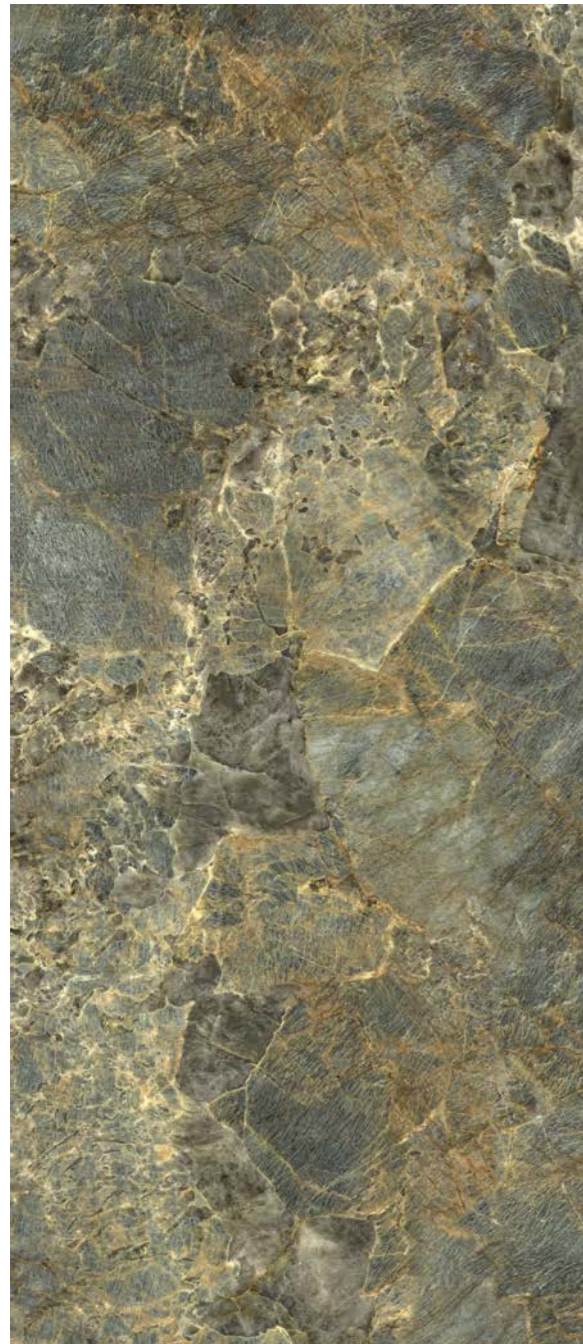

120x280

05476 | Eccentric Lev/Ret



60x120

03349A | Opulence Eccentric Lev/Ret



60x120

03591A | Opulence Botanic Lev/Ret

Imballi

Packing
Verpackung
Emballage

Formati Sizes		± MM	Pezzi Scatola Pieces/Box Stck/Karton Carreaux/Boîte	Mq/Scatola Sqmt/Box Qm/Karton M2/Boîte	Kg/Scatola Kgs/Box Kg/Karton Kg/Boîte	Scatole/Paletta Boxes/Pallet Karton/Palette Boîte/Palette	Mq/Paletta Sqmt/Pallet Qm/Pallet M2/Palette	Kg/Paletta Kgs/Pallet Kg/Pallet Kg/Palette	Formato Paletta Size Pallet Format Pallet Dim. Palette
120x280 (48"x110") Lev/Ret	P	6	1	3,36	46,50	20	67,20	930	143x294x35
60x120 (24"x48") Lev/Ret	P	9,5	2	1,44	32,00	30	43,20	960	122x82x75
60x120 (24"x48") Botanic Lev/Ret	P		2	1,44	32,00	15	21,60	-	-
25x50 (10"x20") Illusion Lev/Ret	P		4	0,5	10,5	40	-	-	-
30x30 (12"x12") Balance	P		6	0,54	11,5	54	-	-	-
Pezzi Speciali / Special Pieces									
33x120 (13"x48") Gradino Costa Retta Lev/Ret	P		2	0,792	18,50	20	-	-	-
1,5x120 (½"x48") Bacchetta Jolly Lev/Ret	P		6	0,108	2,50	48	-	-	-
1,5x1,5 (½"x½") Unghia Jolly Lev/Ret	P		6	0,001	0,50	48	-	-	-

Riepilogo Gamma

Collection
Serie
Gamme

	Formati Sizes	± MM					Pezzi Speciali Special Pieces			
	120x280 48"x110"	± 6	60x120 24"x48"	± 9,5	Botanic 60x120 24"x48"	Balance 30x30 12"x12"	Illusion 25x50 10"x20"	Gradino Costa Retta 33x120 13"x48"	Bacchetta Jolly 1,5x120 ½"x48"	Unghia Jolly 1,5x1,5 ½"x½"
Bliss	Lev/Ret		03346A	V4	03591A	03443		03381A	03386A	03392
Delight	Lev/Ret		03347A	V4	03591A			03382A	03387A	03393
Eccentric	Lev/Ret	05476	03349A	V4	03591A			03384A	03389A	03395
Pleasure	Lev/Ret		03348A	V4	03591A	03443		03383A	03388A	03394
Caprice	Lev/Ret		03351A	V4			03445	03385A	03391A	03396

* Decorì realizzati con smalti e metalli preziosi. Vedere nota a pag. 366-367
Decors made with glazes and precious metals. See note on pages 366-367
Dekore aus Glasuren und Edelmetallen. Siehe Hinweis auf Seiten 366-367
Décors réalisés avec des émaux et des métaux précieux. Voir note aux pages 366-367

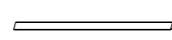
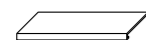

Elegance

Elegance è la soluzione ideale per arredare ogni ambiente con sobria raffinatezza. Grandi formati e texture che riproducono in ogni dettaglio i marmi più preziosi al mondo per una linea che ricopre di eleganza ogni superficie.

Elegance is the ideal solution for covering any interior with sober refinement. Large sizes and textures which reproduce in detail the most precious marbles in the world, for a line of materials capable of conveying elegance to any surface.

Elegance ist die ideale Lösung, um jedes Ambiente in schlichte Noblesse zu kleiden. Großformate und Texturen, die detailgetreu die wertvollsten Marmorsorten der Welt nachempfinden. Diese Fliesenlinie schenkt jeder Fläche bestechende Eleganz.

Elegance est la solution parfaite pour revêtir chaque pièce d'un raffinement sobre. De grands formats et des textures reproduisant fidèlement les marbres les plus précieux au monde, pour une ligne de carreaux habillant avec élégance chaque surface.

3

Colori
Colours
Farben
Couleurs

Via Condotti

Piazza di Spagna

Via della Spiga

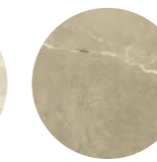
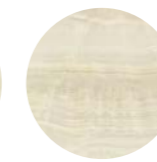

2

Formati
Sizes
Formate
Formats

60×120
24"×48"

80×80
31½"×31½"



1

Superfici
Surfaces
Oberflächen
Surfaces

Levigato

i

Effetto Marmo
Marble Look
Marmoroptik
Effet Marbre

Rivestimento
Wall Tiles
Wandfliesen
Revêtement

Pavimento
Floor Tiles
Bodenfliesen
Sol

Gres fine porcellanato
Fine porcelain stoneware
Feinsteinzeug
Grès cérame fin

Tecnologia digitale
Digital technology
Digital Technologie
Technologie numérique



Via Condotti



80x80
03621 | Via Condotti Lev/Ret



60x120
03045A | Via Condotti Lev/Ret



5x30
01541 | Bordo Via Condotti



30x30
01493 | Mosaico
Via Condotti



30x30
01497 | Intreccio
Condotti / Spiga



Via della Spiga



80x80
03622 | Via della Spiga Lev/Ret



60x120
03047A | Via Della Spiga Lev/Ret



5x30
01543 | Bordo Via della Spiga



30x30
01495 | Mosaico
Via della Spiga



30x30
01497 | Intreccio
Condotti/Spiga

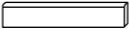

Piazza di Spagna



80x80

03838 | Piazza di Spagna Lev/Ret



60x120

03046A | Piazza di Spagna Lev/Ret



5x30

01542 | Bordo Piazza di Spagna



30x30

01494 | Mosaico Piazza di Spagna



Elegance

Imballi

Packing
Verpackung
Emballage

Formati Sizes		± MM	Pezzi Scatola Pieces/Box Stck/Karton Carreaux/Boîte	Mq/Scatola Sqmt/Box Qm/Karton M2/Boîte	Kg/Scatola Kgs/Box Kg/Karton Kg/Boîte	Scatole/Paletta Boxes/Pallet Karton/Palette Boîte/Palette	Mq/Paletta Sqmt/Pallet Qm/Pallet M2/Palette	Kg/Paletta Kgs/Pallet Kg/Pallet Kg/Palette	Formato Paletta Size Pallet Format Pallet Dim. Palette
80x80 (31½"x31½") Lev/Ret	P	9,5	2	1,28	27,5	50	64,00	1375	122x80x96
60x120 (24"x48") Lev/Ret	P	9,5	2	1,44	32	30	43,20	960	122x82x75
30x30 (12"x12") Mosaico (su rete)	P		6	0,54	10,2	54			
30x30 (12"x12") Intreccio (su rete)	P		6	0,54	10,2	54			
5x30 (2"x12") Bordo	P		10	0,15	2,5	140			
Pezzi Speciali / Special Pieces									
8x80 (3¼"x31½") Battiscopa Lev/Ret	P		7	0,448	11	65	-	-	-
6,5x120 (2½"x48") Battiscopa Lev/Ret	P		8	0,624	14	48	-	-	-

Riepilogo Gamma

Collection
Serie
Gamme

Formati Sizes	80x80 31½"x31½"		60x120 24"x48"		PEI		Mosaico 30x30 Su Rete 12"x12" (½"x½" Dot)	Intreccio 30x30 Su Rete 12"x12" (1¼"x1¼" Dot)	Bordo 5x30 2"x12"	Pezzi Speciali Special Pieces	
	± 9,5	± 9,5	Battiscopa 8x80 3¼"x31½"	Battiscopa 6,5x120 2½"x48"							
Via Condotti	Lev/Ret	03621	03045A	V3	V	01493	01497	01541	01443	01438	
Piazza di Spagna	Lev/Ret	03838	03046A	V3	V	01494		01542	01444	01439	
Via della Spiga	Lev/Ret	03622	03047A	V3	V	01495	01497	01543	01445	01441	



WOOD EFFECT

Effetto Legno / Holzoptik / Effet Bois



CLICK



- 244 [Solovere](#) FLOOR AND MORE /
- 256 [Fleur De Bois](#) FLOOR AND MORE /
- 266 [Sou!](#) FLOOR AND MORE /
- 272 [Cottage](#) FLOOR AND MORE

Solorovere

Naturale, fiammato, grintoso o vintage?
Solorovere, una collezione di doghe in gres porcellanato che esprime l'essenza del rovere in quattro diverse declinazioni.

Natural, flamed, bold or vintage?
Solorovere, a collection of porcelain stoneware staves that expresses the essence of oak in four variations.

Natürlich, geflammt, kräftig oder vintage?
Solorovere, eine Kollektion von Feinsteinzeugleisten, die die Essenz der Eiche in vier verschiedenen Abweichungen zum Ausdruck bringt.

Naturel, Flammé, Moderne ou Vintage ?
Solorovere, une collection de lames parquet en grès cérame qui exprime l'essence du chêne en quatre variantes différentes.

4

Colori
Colours
Farben
Couleurs

Pure

Flamed

Loft

Vintage

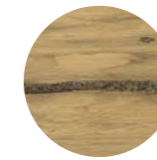
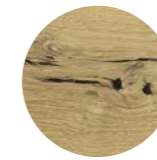

3

Formati
Sizes
Formate
Formats

30×120
12"×48"

20×120
8"×48"

10×53
4"×20"

3

Superfici
Surfaces
Oberflächen
Surfaces

Naturale

Antislip

Grip

i

Effetto Legno
Wood Look
Holzoptik
Effet Bois

Rivestimento
Wall Tiles
Wandfliesen
Revêtement

Pavimento
Floor Tiles
Bodenfliesen
Sol

Gres fine porcellanato ad impasto colorato
Coloured-body fine porcelain stoneware
Feinsteinzeug aus farbiger Masse
Grès cérame fin à pâte colorée

Tecnologia digitale
Digital technology
Digital Technologie
Technologie numérique

WATCH THE VIDEO



Pure



20x120
05388 | Pure Nat/Ret



20x120
05405 | Flamed Cannelé Nat/Ret



10x53
05399 | Chevron Pure Nat/Ret

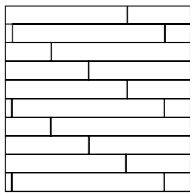

Posa Corretta
Correct Laying

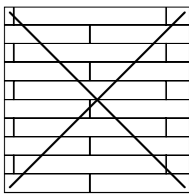

Posa Sconsigliata
Wrong Laying No 50%

Per un risultato di posa ottimale si consiglia di prelevare i listoni da 5 scatole contemporaneamente.

For best installation results, we suggest taking the floorboard tiles from 5 boxes at the same time.

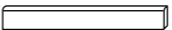



Flamed



20x120
05389 | Flamed Nat/Ret
05393 | Flamed Antislip/Ret



20x120
05405 | Flamed Cannelé Nat/Ret



10x53 - 4"x20"
05401 | Chevron Flamed Nat/Ret

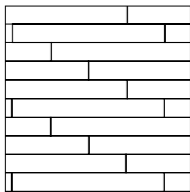

Posa Corretta
Correct Laying

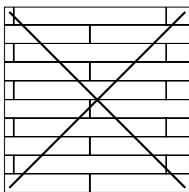

Posa Sconsigliata
Wrong Laying No 50%

Per un risultato di posa ottimale si consiglia di prelevare i listoni da 5 scatole contemporaneamente.

For best installation results, we suggest taking the floorboard tiles from 5 boxes at the same time.



Loft



20x120
05391 | Loft Nat/Ret
05394 | Loft Antislip/Ret



30x120
05596 | Loft Grip/Ret ± 20mm



20x120
05404 | Loft Cannelé Nat/Ret



10x53
05402 | Chevron Loft Nat/Ret

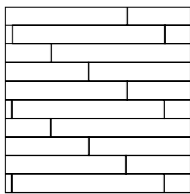

Posa Corretta
Correct Laying

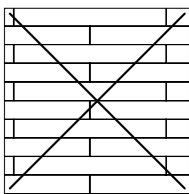

Posa Sconsigliata
Wrong Laying No 50%

Per un risultato di posa ottimale si consiglia di prelevare i listoni da 5 scatole contemporaneamente.

For best installation results, we suggest taking the floorboard tiles from 5 boxes at the same time.



Vintage



20x120
05392 | Vintage Nat/Ret



30x120
05597 | Vintage Grip/Ret ± 20mm



20x120
05404 | Loft Cannelé Nat/Ret



10x53
05403 | Chevron Vintage Nat/Ret

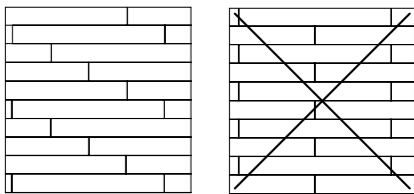

Posa Corretta
Correct Laying

Posa Sconsigliata
Wrong Laying No 50%

Per un risultato di posa ottimale si consiglia di prelevare i listoni da 5 scatole contemporaneamente.

For best installation results, we suggest taking the floorboard tiles from 5 boxes at the same time.

Imballi

Packing
Verpackung
Emballage

Riepilogo Gamma

Collection
Serie
Gamme

CLICK

PDF Merchandising

Formati Sizes	MM	Pezzi Scatola Pieces/Box Stck/Karton Carreaux/Boîte	Mq/Scatola Sqmt/Box Qm/Karton M2/Boîte	Kg/Scatola Kgs/Box Kg/Karton Kg/Boîte	Scatole/Paletta Boxes/Pallet Karton/Palette Boîte/Palette	Mq/Paletta Sqmt/Pallet Qm/Pallet M2/Palette	Kg/Paletta Kgs/Pallet Kg/Pallet Kg/Palette	Formato Paletta Size Pallet Format Pallet Dim. Palette
30x120 (12"x48") Grip/Ret	P	20	2	33,05	36	25,92	1189,8	122x96x70
20x120 (8"x48") Nat/Ret - Antislip/Ret	P	8,5	5	23,00	48	57,6	1104	122x82x75
20x120 (8"x48") Canneté Nat/Ret	P	8,5	4	18,00	36	34,56	648	122x82x75
10x53 (4"x20") Nat/Ret	P	8,5	12	13,20	60	38,16	792	120x80x75
Pezzi Speciali / Special Pieces								
4,5x120 (1¾"x48") Battiscopa Nat/Ret	P	8,5	6	6,10	48	-	-	-

Formati Sizes	MM	Pezzi Scatola Pieces/Box Stck/Karton Carreaux/Boîte	Mq/Scatola Sqmt/Box Qm/Karton M2/Boîte	Kg/Scatola Kgs/Box Kg/Karton Kg/Boîte	Scatole/Paletta Boxes/Pallet Karton/Palette Boîte/Palette	Mq/Paletta Sqmt/Pallet Qm/Pallet M2/Palette	Kg/Paletta Kgs/Pallet Kg/Pallet Kg/Palette	Formato Paletta Size Pallet Format Pallet Dim. Palette	Stucchi Consigliati Recommended grouts Joints recommandés Empfohlene Fugen			Pezzi Speciali Special Pieces
									Din 51130	Din 51097	Dcof	
Pure	Nat/Ret	20	2	33,05	36	25,92	1189,8	122x96x70	R10	A+B	>0.42	Battiscopa 4,5x120 - 1¾"x48"
	Antislip/Ret	8,5	5	23,00	48	57,6	1104	122x82x75	R11	A+B+C	>0.42	
Flamed	Nat/Ret	8,5	5	23,00	48	57,6	1104	122x82x75	R10	A+B	>0.42	
	Antislip/Ret	8,5	5	23,00	48	57,6	1104	122x82x75	R11	A+B+C	>0.42	
Loft	Nat/Ret	8,5	5	23,00	48	57,6	1104	122x82x75	R10	A+B	>0.42	
	Grip/Ret	8,5	5	23,00	48	57,6	1104	122x82x75	R11	A+B+C	>0.42	
Vintage	Nat/Ret	8,5	5	23,00	48	57,6	1104	122x82x75	R10	A+B	>0.42	
	Grip/Ret	8,5	5	23,00	48	57,6	1104	122x82x75	R11	A+B+C	>0.42	

Fleur de Bois

Una collezione ispirata ad un mix essenze di noce americano e di noce nazionale sapientemente miscelate tra loro, alla ricerca dell'equilibrio per coglierne le migliori espressioni estetiche; quelle date dalle tipiche venature longitudinali con andamento regolare ed elegante.

A collection inspired by a mix of woods types – hickory and Italian walnut – skilfully blended in order to achieve a balance and highlight their best aesthetic expressions; those produced by typical longitudinal grains with a regular and elegant pattern.

Eine Kollektion, die sich an einem gelungenen Mix aus amerikanischem und europäischem Walnussbaum inspiriert, wobei die schönsten Ausdrucksformen zu einem ausgewogenen Ganzen komponiert wurden.

Cette collection s'inspire d'un mélange d'essences de noyer d'Amérique et de noyer d'Italie, savamment associées l'une à l'autre en un équilibre qui exalte leurs plus belles expressions esthétiques.

8

Colori
Colours
Farben
Couleurs

Blanc

Gris

Naturel

Beige

Brun

Glacé

Miel

Chocolat

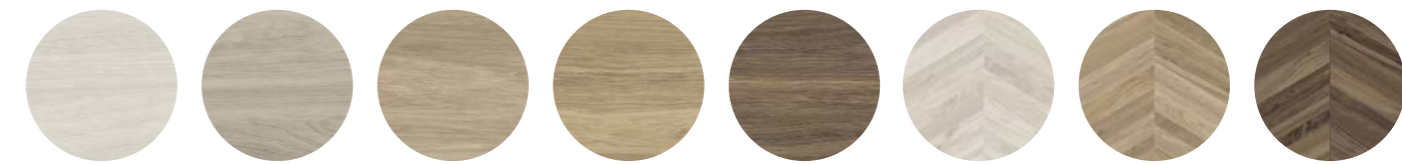

4

Formati
Sizes
Formate
Formats

60×120
24"×48"

20×120
8"×48"

22,5×90
9"×36"

15×90
6"×36"

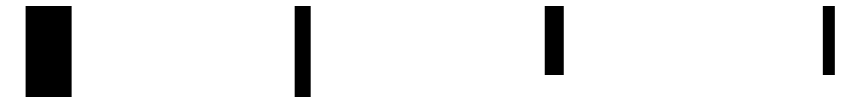

2

Superfici
Surfaces
Oberflächen
Surfaces

Naturale

Antislip

i

Effetto Legno
Wood Look
Holzoptik
Effet Bois

Rivestimento
Wall Tiles
Wandfliesen
Revêtement

Pavimento
Floor Tiles
Bodenfliesen
Sol

Gres fine porcellanato ad impasto colorato
Coloured-body fine porcelain stoneware
Feinsteinzeug aus farbiger Masse
Grès cérame fin à pâte colorée

Tecnologia digitale
Digital technology
Digital Technologie
Technologie numérique

Ripresa grafica tra le diverse lastre rettificate contenute entro le tolleranze previste dalla norma. Per un corretto allineamento si consiglia di utilizzare una fuga di 2 mm.
Graphic representation between the rectified tiles is contained within the tolerances provided by the standard. For a correct alignment it is recommended to use a 2 mm joint.
Grafische Darstellung zwischen den verschiedenen rektifizierten Platten innerhalb der in der Norm vorgesehenen Toleranzen. Für eine korrekte Anpassung wird eine Fuge von 2mm empfohlen.
Reproduction graphique entre les différents carreaux rectifiés dans les limites des tolérances prévues par la norme. Pour un alignement correct, il est recommandé d'utiliser joints de 2 mm.

WATCH THE VIDEO



Blanc



20x120
03015B | Fleur De Bois Blanc Nat/Ret
03458B | Fleur De Bois Blanc Antislip/Ret



22,5x90
03699 | Fleur De Bois Blanc Nat/Ret



15x90
03698 | Fleur De Bois Blanc Nat/Ret

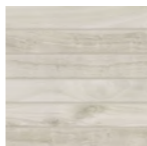

30x30
02046 | Fleur de Bois Blanc Linear Nat/Ret



20x20
02052 | Fleur de Bois Blanc Tarsia Nat/Ret



Gris



20x120
03014B | Fleur De Bois Gris Nat/Ret
03457B | Fleur De Bois Gris Antislip/Ret



22,5x90
03815 | Fleur De Bois Gris Nat/Ret



15x90
03821 | Fleur De Bois Gris Nat/Ret



30x30
02045 | Fleur de Bois Gris Linear Nat/Ret

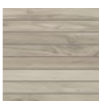

20x20
02051 | Fleur de Bois Gris Tarsia Nat/Ret

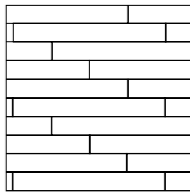

Posa Corretta
Correct Laying

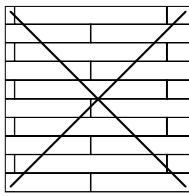

Posa Sconsigliata
Wrong Laying No 50%

Per un risultato di posa ottimale si consiglia di prelevare i listoni da 5 scatole contemporaneamente.

For best installation results, we suggest taking the floorboard tiles from 5 boxes at the same time.



Naturel



20x120
03013B | Fleur De Bois Naturel Nat/Ret
03459B | Fleur De Bois Naturel Antislip/Ret



22,5x90
03697 | Fleur De Bois Naturel Nat/Ret



15x90
03696 | Fleur De Bois Naturel Nat/Ret

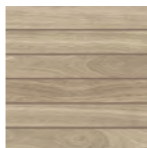

30x30
02047 | Fleur de Bois Naturel Linear Nat/Ret



20x20
02053 | Fleur de Bois Naturel Tarsia Nat/Ret



Beige



20x120
03016B | Fleur De Bois Beige Nat/Ret
03461B | Fleur De Bois Beige Antislip/Ret



22,5x90
03816 | Fleur De Bois Beige Nat/Ret



15x90
03822 | Fleur De Bois Beige Nat/Ret



30x30
02048 | Fleur de Bois Beige Linear Nat/Ret



20x20
02054 | Fleur de Bois Beige Tarsia Nat/Ret

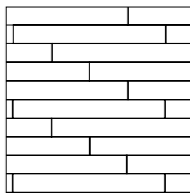

Posa Corretta
Correct Laying

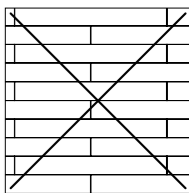

Posa Sconsigliata
Wrong Laying No 50%

Per un risultato di posa ottimale si consiglia di prelevare i listoni da 5 scatole contemporaneamente.

For best installation results, we suggest taking the floorboard tiles from 5 boxes at the same time.

Brun



20x120

03017B | Fleur De Bois Brun Nat/Ret
03462B | Fleur De Bois Brun Antislip/Ret



22,5x90

03817 | Fleur De Bois Brun Nat/Ret



15x90

03823 | Fleur De Bois Brun Nat/Ret

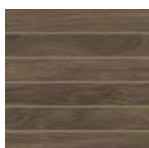

30x30

02049 | Fleur de Bois Brun Linear Nat/Ret

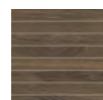

20x20

02055 | Fleur de Bois Brun Tarsia Nat/Ret

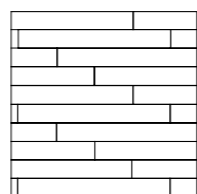

Posa Corretta
Correct Laying

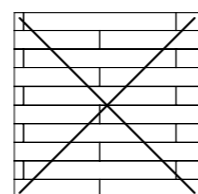

Posa Sconsigliata
Wrong Laying No 50%

Per un risultato di posa ottimale si consiglia di prelevare i listoni da 5 scatole contemporaneamente.

For best installation results, we suggest taking the floorboard tiles from 5 boxes at the same time.



Chevron Glace



60x120

03025A | Chevron Glace Nat/Ret

Chevron Miel



60x120

03024A | Chevron Miel Nat/Ret

Chevron Chocolat



60x120

03026A | Chevron Chocolat Nat/Ret

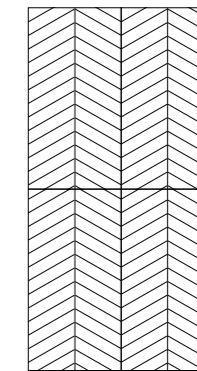

Posa corretta
Correct laying

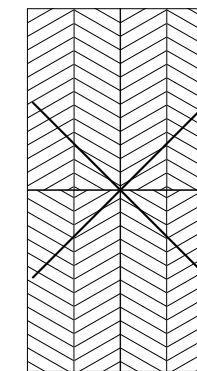

Posa sconsigliata
Wrong laying

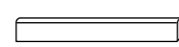
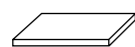

Imballi

Packing
Verpackung
Emballage

Riepilogo Gamma

Collection
Serie
Gamme

Formato / Size		± MM	Pezzi Scatola Pieces/Box Stck/Karton Carreaux/Boîte	Mq/Scatola Sqmt/Box Qm/Karton M2/Boîte	Kg/Scatola Kgs/Box Kg/Karton Kg/Boîte	Scatole/Paletta Boxes/Pallet Karton/Palette Boîte/Palette	Mq/Paletta Sqmt/Pallet Qm/Pallet M2/Palette	Kg/Paletta Kgs/Pallet Kg/Pallet Kg/Palette	Formato Paletta Size Pallet Format Pallet Dim. Palette
20×120 (8"×48") Nat/Ret - Antislip/Ret	P	8,5	5	1,200	23,00	48	57,60	1104	122×82×75
22,5×90 (9"×36") Nat/Ret	P	9,5	6	1,215	26,00	54	65,61	1404	120×90×85
15×90 (6"×36") Nat/Ret	P	9,5	9	1,215	26,00	48	58,32	1248	120×90×76
60×120 (24"×48") Chevron Nat/Ret	P	9,5	2	1,44	31,00	30	43,20	930	122×82×75
30×30 (12"×12") Linear Nat/Ret	P	9,5	11	0,990	17,50	36	-	-	-
20×20 (8"×8") Tarsia Nat/Ret	P	9,5	6	0,240	5,00	105	-	-	-
Pezzi Speciali / Special Pieces									
20×120 (8"×48") Step Nat/Ret	P	8,5	4	0,960	22,70	36	-	-	-
6,5×120 (2½"×48") Battiscopa Nat/Ret	P	8,5	8	0,624	14,00	48	-	-	-
7×90 (2¾"×36") Battiscopa Nat/Ret	P	9,5	8	0,504	13,00	48	-	-	-

	Formati Sizes	20×120 8"×48"	22,5×90 9"×36"	15×90 6"×36"	Chevron 60×120 24"×48"	DIN 51130	DIN 51097	DCOF	Linear 30×30 12"×12"	Tarsia 20×20 8"×8"	Pezzi Speciali Special Pieces			
		± 8,5	± 9,5	± 9,5	± 9,5						Step 20×120 8"×48"	Battiscopa 7×90 2¾"×36"	Battiscopa 6,5×120 2½"×48"	
Blanc	Nat/Ret	03015B	03699	03698		V3	R9	A	>0.42	02046	02052	02076	02083	02088
	Antislip/Ret	03458B					R11	A+B+C	>0.42					
Gris	Nat/Ret	03014B	03815	03821		V3	R9	A	>0.42	02045	02051	02075	02082	02087
	Antislip/Ret	03457B					R11	A+B+C	>0.42					
Naturel	Nat/Ret	03013B	03697	03696		V3	R9	A	>0.42	02047	02053	02077	02084	02089
	Antislip/Ret	03459B					R11	A+B+C	>0.42					
Beige	Nat/Ret	03016B	03816	03822		V3	R9	A	>0.42	02048	02054	02078	02085	02091
	Antislip/Ret	03461B					R11	A+B+C	>0.42					
Brun	Nat/Ret	03017B	03817	03823		V3	R9	A	>0.42	02049	02055	02079	02086	02092
	Antislip/Ret	03462B					R11	A+B+C	>0.42					
Glace	Nat/Ret				03025A		R9	A	>0.42					
Miel	Nat/Ret				03024A		R9	A	>0.42					
Chocolat	Nat/Ret				03026A		R9	A	>0.42					

Soul

L'essenza regina di tutti i legni è il rovere di quercia, capace di esprimersi in una moltitudine di possibilità. La ricerca Piemme ne ha indagato l'anima nel profondo, liberandola in tre principali declinazioni: naturale, rustico, recuperato.

The queen of wood is oak and it can express itself in a multitude of ways. Piemme research delved into its soul and declined its multifaceted nature in three ways: natural, rustic and reclaimed.

Die edelste aller Holzarten ist das Eichenholz, das seine Ausstrahlungskraft auf vielfältige Art zum Ausdruck bringen kann. Die Piemme Forschung hat sich eingehend mit dem Wesen dieses Holzes befasst und dieses in drei Hauptvarianten optisch umgesetzt: natürlich, rustikal, und gealtert.

Le roi de tous les bois est le chêne rouvre, en mesure d'adopter une multitude d'expressions différentes. La recherche Piemme a fouillé au plus profond de son âme pour en tirer trois principales formes: naturelle, rustique, de récupération.

4

Colori
Colours
Farben
Couleurs

Pure



Nordic



Knots



Reclaimed



1

Formati
Sizes
Formate
Formats

20×120
8"×48"



2

Superfici
Surfaces
Oberflächen
Surfaces

Naturale Grip

i

Effetto Legno
Wood Look
Holzoptik
Effet Bois

Rivestimento
Wall Tiles
Wandfliesen
Revêtement

Pavimento
Floor Tiles
Bodenfliesen
Sol

Gres fine porcellanato ad impasto colorato
Coloured-body fine porcelain stoneware
Feinsteinzeug aus farbiger Masse
Grès cérame fin à pâte colorée

Tecnologia digitale
Digital technology
Digital Technologie
Technologie numérique

▶ WATCH THE VIDEO



Gres fine porcellanato ad impasto colorato / Tecnologia digitale
Coloured-body fine porcelain stoneware / Digital technology

Feinsteinzeug aus farbiger Masse / Digital Technologie
Grès cérame fin à pâte colorée / Technologie numérique

Pure



20x120
02947B | Soul Pure Nat/Ret



20x15
02989 | Soul Kaleido Light Nat/Ret



19x22
02988 | Soul Mosaico Rolo Nat/Ret

Nordic



20x120
02948B | Soul Nordic Nat/Ret



19x22
02988 | Soul Mosaico Rolo Nat/Ret

Knots



20x120
02951B | Soul Knots Nat/Ret
03094B | Soul Knots Grip/Ret



19x22
02988 | Soul Mosaico Rolo Nat/Ret

Reclaimed



20x120
02953B | Soul Reclaimed Nat/Ret
03095B | Soul Reclaimed Grip/Ret



20x15
02990 | Soul Kaleido Dark Nat/Ret



20x120
02986B | Soul Shield Nat/Ret

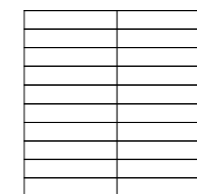

Posa Corretta (Shield)
(Shield) correct laying

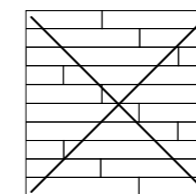

Posa Sfalsata non consentita (Shield)
(Shield) wrong laying

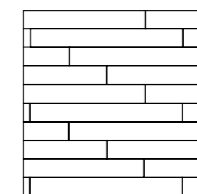

Posa Corretta Fondi 20x119,5
Correct Laying of Tiles 20x119,5

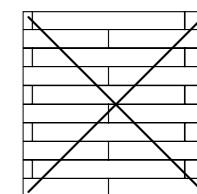

Posa Sconsigliata Fondi 20x119,5
Wrong Laying No 50% Tiles 20x119,5

Per un risultato di posa ottimale si consiglia di prelevare i listoni da 5 scatole contemporaneamente.

For best installation results, we suggest taking the floorboard tiles from 5 boxes at the same time.



Imballi

Packing
Verpackung
Emballage

Formati Sizes		± MM	Pezzi Scatola Pieces/Box Stck/Karton Carreaux/Boîte	Mq/Scatola Sqmt/Box Qm/Karton M2/Boîte	Kg/Scatola Kgs/Box Kg/Karton Kg/Boîte	Scatole/Paletta Boxes/Pallet Karton/Palette Boîte/Palette	Mq/Paletta Sqmt/Pallet Qm/Pallet M2/Palette	Kg/Paletta Kgs/Pallet Kg/Pallet Kg/Palette	Formato Paletta Size Pallet Format Pallet Dim. Palette
20×120 (8"×48") Nat/Ret	P	8,5	5	1,200	23,00	48	57,60	1104	122x82x75
20×120 (8"×48") Grip/Ret	P	8,5	5	1,200	23,00	48	57,60	1104	122x82x75
20×120 (8"×48") Shield Nat/Ret	P	8,5	5	1,200	23,00	48	57,60	1104	122x82x75
20×15 (8"×6") Kaleido	P	8,5	25	0,750	15,50	36	-	-	-
19×22 (7½"×8¾") Mosaico Rolo	P	8,5	11	0,46	10,00	30	-	-	-
Pezzi Speciali / Special Pieces									
4,5×120 (1¾"×48") Battiscopa Nat/Ret	P	8,5	6	0,324	8,00	48	-	-	-

Riepilogo Gamma

Collection
Serie
Gamme

Formati Sizes						Shield 20×120 8"×48"	Kaleido 20×15 8"×6"	Mosaico Rolo 19×22 7½"×8¾"	Battiscopa 4,5×120 1¾"×48"	
		DIN 51130	DIN 51097	DCOF	± 8,5					± 8,5
Pure	Nat/Ret	02947B	V3	R10	A+B	>0.42	02986B	02989	02988	02959A
Nordic	Nat/Ret	02948B	V3	R10	A+B	>0.42	02986B		02988	02960A
Knots	Nat/Ret	02951B	V3	R10	A+B	>0.42	02986B		02988	02961A
	Grip/Ret	03094B		R11	A+B+C	>0.42				
Reclaimed	Nat/Ret	02953B	V3	R10	A+B	>0.42	02986B	02990		02962A
	Grip/Ret	03095B		R11	A+B+C	>0.42				

Cottage

Sensazioni materiche, venature disegnate dal tempo e tonalità naturali: Cottage riveste gli spazi del vivere contemporaneo con l'essenza dei legnami più pregiati.

Tactile sensations, veins designed by time and natural colour shades: Cottage covers contemporary living spaces with the essence of the most precious woods.

Materische Empfindungen, von der Zeit gezeichnete Äderungen und natürliche Farbtöne: Cottage kleidet unsere modernen Lebensräume mit der Seele der edelsten Hölzer.

Des sensations de matière forte, des veinages tracés par le temps et des teintes naturelles; Cottage habille les espaces de vie contemporains avec l'essence des bois les plus précieux

8

Colori
Colours
Farben
Couleurs

Tiglio



Acacia



Olmo



Ulivo



Cipresso

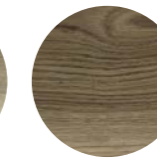

Seraya



Larice



Carpino



3

Formati
Sizes
Formate
Formats

20×120
8"×48"



22,5×90
9"×36"



15×90
6"×36"



2

Superfici
Surfaces
Oberflächen
Surfaces

Naturale

Velvet

1

Strutture 3D
3D structures
Strukturen
Decorations and relief

Velvet



i

Effetto Legno
Wood Look
Holzoptik
Effet Bois

Rivestimento
Wall Tiles
Wandfliesen
Revêtement

Pavimento
Floor Tiles
Bodenfliesen
Sol

Gres Fine porcellanato smaltato
Glazed porcelain Stoneware
Glasierte Feinsteinzeug
Grès cérame émaillé

Tecnologia digitale
Digital technology
Digital Technologie
Technologie numérique



Gres Fine porcellanato smaltato / Tecnologia digitale
Glazed porcelain Stoneware / Digital technology

Glasierte Feinsteinzeug / Digital Technologie
Grès cérame émaillé / Technologie numérique

Wood Effect
FLOOR AND MORE

Tiglio



20x120
03019B | Cottage Tiglio Nat/Ret



22,5x90
03659 | Cottage Tiglio Nat/Ret



15x90
03661 | Cottage Tiglio Nat/Ret



22,5x90
03808 | Cottage Velvet Tiglio Nat/Ret

Acacia



20x120
03022B | Cottage Acacia Nat/Ret



22,5x90
03633 | Cottage Acacia Nat/Ret



15x90
03629 | Cottage Acacia Nat/Ret



22,5x90
03694 | Cottage Velvet Acacia Nat/Ret

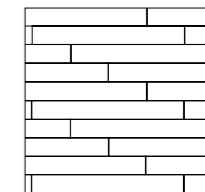

Posa Corretta
Correct Laying

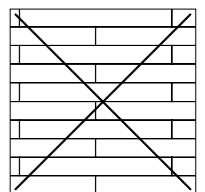

Posa Sconsigliata
Wrong Laying No 50%

Per un risultato di posa ottimale si consiglia di prelevare i listoni da 5 scatole contemporaneamente.

For best installation results, we suggest taking the floorboard tiles from 5 boxes at the same time.

Olmo



20x120
02991B | Cottage Olmo Nat/Ret



22,5x90
03689 | Cottage Olmo Nat/Ret



15x90
03688 | Cottage Olmo Nat/Ret

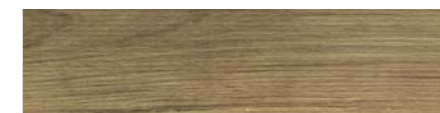

22,5x90
03811 | Cottage Velvet Olmo Nat/Ret



Ulivo



20x120
03018B | Cottage Ulivo Nat/Ret



22,5x90
03631 | Cottage Ulivo Nat/Ret



15x90
03627 | Cottage Ulivo Nat/Ret



22,5x90
03809 | Cottage Velvet Ulivo Nat/Ret

Cipresso



20x120
02992B | Cottage Cipresso Nat/Ret



22,5x90
03632 | Cottage Cipresso Nat/Ret



15x90
03628 | Cottage Cipresso Nat/Ret

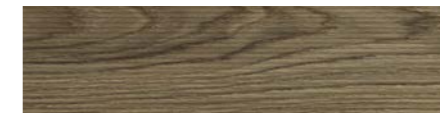

22,5x90
03695 | Cottage Velvet Cipresso Nat/Ret

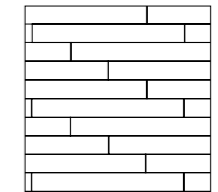

Posa Corretta
Correct Laying

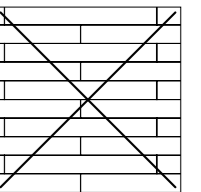

Posa Sconsigliata
Wrong Laying No 50%

Per un risultato di posa ottimale si consiglia di prelevare i listoni da 5 scatole contemporaneamente.

For best installation results, we suggest taking the floorboard tiles from 5 boxes at the same time.

Seraya



20x120
03021B | Cottage Seraya Nat/Ret



22,5x90
03807 | Cottage Seraya Nat/Ret



15x90
03819 | Cottage Seraya Nat/Ret

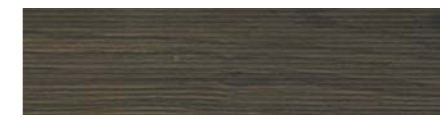

22,5x90
03812 | Cottage Velvet Seraya Nat/Ret



Larice



20x120
03023B | Cottage Larice Nat/Ret



22,5x90
03693 | Cottage Larice Nat/Ret



15x90
03691 | Cottage Larice Nat/Ret



22,5x90
03814 | Cottage Velvet Larice Nat/Ret

Carpino



20x120
03020B | Cottage Carpino Nat/Ret



22,5x90
03806 | Cottage Carpino Nat/Ret



15x90
03818 | Cottage Carpino Nat/Ret

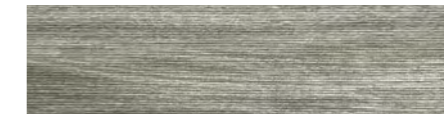

22,5x90
03813 | Cottage Velvet Carpino Nat/Ret

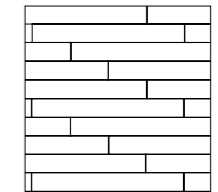

Posa Corretta
Correct Laying

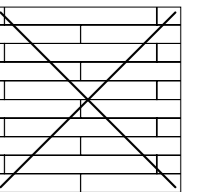

Posa Sconsigliata
Wrong Laying No 50%

Per un risultato di posa ottimale si consiglia di prelevare i listoni da 5 scatole contemporaneamente.

For best installation results, we suggest taking the floorboard tiles from 5 boxes at the same time.



15x15
00278 | Maiolica Blu Ret









15x15
00279 | Maiolica Cotto Ret







15x15
00281 | Maiolica Grigio Ret

Packing
Verpackung
Emballage

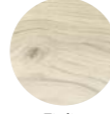
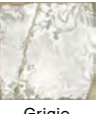
Collection
Serie
Gamme

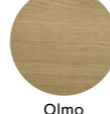
Formato / Size		± MM	 Pezzi/Scatola Pieces/Box Stck/Karton Carreaux/Boîte	 Mq/Scatola Sqmt/Box Qm/Karton M2/Boîte	 Kg/Scatola Kgs/Box Kg/Karton Kg/Boîte	 Scatole/Paletta Boxes/Pallet Karton/Pallet Boîte/Palette	 Mq/Paletta Sqmt/Pallet Qm/Pallet M2 /Palette	 Kg/Paletta Kgs/Pallet Kg/Pallet Kg/Palette	 Formato Paletta Size Pallet Format Pallet Dim. Palette
20x120 Nat/Ret	P	8,5	5	1,200	23	48	57,60	1104	122*82*75
15*90 Nat/Ret	P	9,5	9	1,215	26	48	58,32	1248	120*90*76
22,5*90 Nat/Ret - Velvet/Ret	P	9,5	6	1,215	26	54	65,61	1404	120*90*85
15*15 Maiolica Ret	P	9,5	6	0,135	3,4	55			
Pezzi Speciali / Special Pieces									
6,5*120 Battiscopa	P	8,5	8	0,624	14	48			
7*90 Battiscopa	P	9,5	8	0,504	13	48			
22,5*90 Step	P	9,5	4	0,81	20	72			

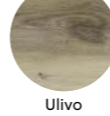
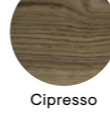
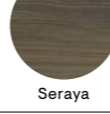
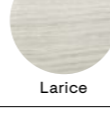
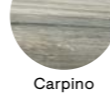
Formati Sizes		20*120 8"*48"	22,5*90 9"*36"	15*90 6"*36"	DIN 51130	DIN 51097	DCOF	Pezzi Speciali Special Pieces			Formati Sizes	Maiolica 15*15 6"*6"			
		Velvet 22,5*90 9"*36"	Battiscopa 6,5*120 2½"*48"	Battiscopa 7*90 2¼"*36"				Step Velvet 22,5*90 9"*36"	± 9,5	± 8,5			± 9,5	± 9,5	
 Tiglio	Nat/Ret	03019B	03659	03661	V3	R10	A+B	> 0,42		00951	00121		 Grigio	Nat/Ret	00281
	Velvet/Ret		03808			R11	A+B+C		03808		00273				
 Acacia	Nat/Ret	03022B	03633	03629	V3	R10	A+B	> 0,42		00957	00349		 Blu	Nat/Ret	00278
	Velvet/Ret		03694			R11	A+B+C		03694		00352				
 Olmo	Nat/Ret	02991B	03689	03688	V3	R10	A+B	> 0,42		00955	00124		 Cotto	Nat/Ret	00279
	Velvet/Ret		03811			R11	A+B+C		03811		00277				
 Ulivo	Nat/Ret	03018B	03631	03627	V3	R10	A+B	> 0,42		00953	00122				
	Velvet/Ret		03809			R11	A+B+C		03809		00275				
 Cipresso	Nat/Ret	02992B	03632	03628	V3	R10	A+B	> 0,42		00954	00123				
	Velvet/Ret		03695			R11	A+B+C		03695		00276				
 Seraya	Nat/Ret	03021B	03807	03819	V3	R10	A+B	> 0,42		00956	00125				
	Velvet/Ret		03812			R11	A+B+C		03812		00354				
 Larice	Nat/Ret	03023B	03693	03691	V3	R10	A+B	> 0,42		00958	00351				
	Velvet/Ret		03814			R11	A+B+C		03814		00353				
 Carpino	Nat/Ret	03020B	03806	03818	V3	R10	A+B	> 0,42		00952	00212				
	Velvet/Ret		03813			R11	A+B+C		03813		00274				

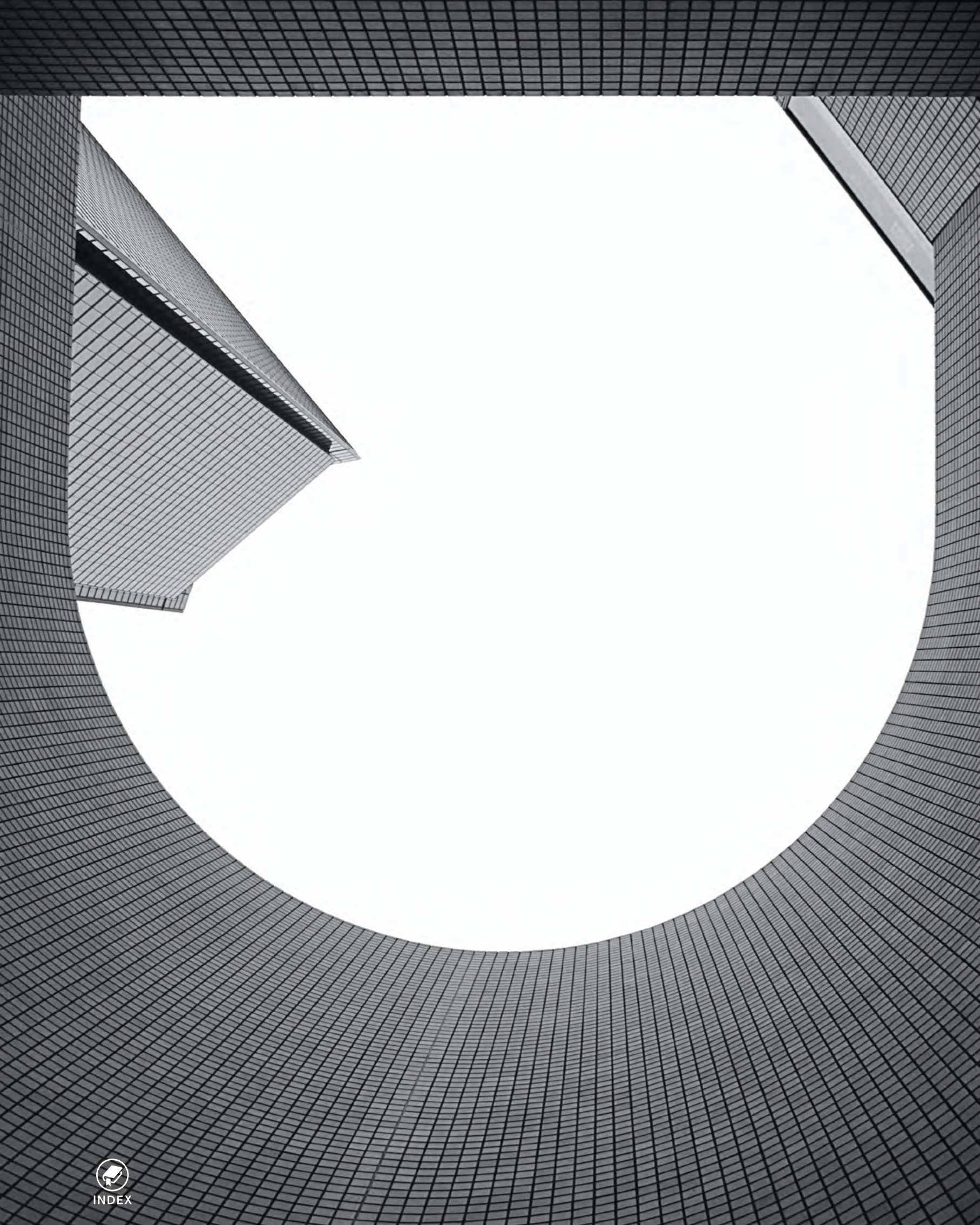

CONTEMPORARY

Contemporaneo / Moderne / Contemporain

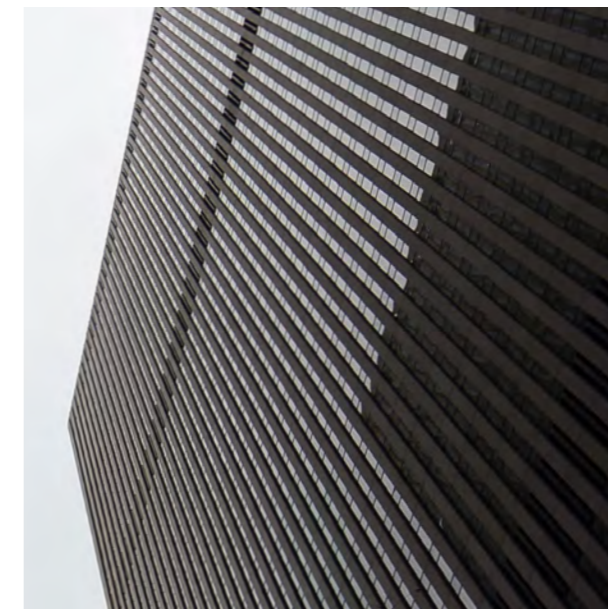

CLICK



284 [Homey](#) PREMIUM /

306 [Materia](#) FLOOR AND MORE /

324 [Fragments](#) FLOOR AND MORE

Homey

La serie Homey è ispirata all'idea di ottenere superfici dall'aspetto naturale prendendo spunto dalla terra, nello specifico l'argilla con i suoi colori caldi e le sfumature 'ton sur ton' ottenendo una superficie morbida, ideale per una casa calda e confortevole. Dall'argilla, pressata in forme stabilite, asciugata e cotta vengono creati i laterizi di vari ornamenti architettonici utilizzati in edilizia. La collezione Homey trae ispirazione da queste forme di laterizio e propone una struttura a mattoncini sia in versione naturale che smaltata lucida.

The Homey series is inspired by the idea of obtaining natural-looking surfaces inspired by the earth, specifically clay with its warm colors and shades 'ton sur ton' obtaining a soft surface, ideal for a warm and cozy home. From the clay, pressed in established forms, then dried and fired, are created the bricks of various architectural ornaments used in construction. The Homey collection draws inspiration from these brick shapes and presents a structure in both natural and glossy finish.

Die Homey-Serie ist von der Idee inspiriert, natürlich aussehende Oberflächen zu erhalten, die sich von der Erde inspirieren lassen, insbesondere die Tonerde mit seinen warmen Farb- auf Farbtönen, um eine sanfte Oberfläche zu erhalten, die ideal für ein warmes und komfortables Zuhause ist. Aus dem fest gepressten Ton, der anschließend getrocknet und gebrannt wird, entstehen die Ziegelsteine verschiedener architektonischer Ornamente, die im Bauwesen verwendet werden. Die Homey-Kollektion ist von diesen Ziegelformen inspiriert und bietet eine Ziegelstruktur sowohl in natürlicher als auch in glänzend glasierter Ausführung.

La série Homey est inspirée par l'idée d'obtenir des surfaces à l'aspect naturel en s'inspirant de la terre, en particulier l'argile avec ses couleurs chaudes et les nuances 'ton sur ton' en obtenant une surface douce, idéale pour une maison chaude et confortable. À partir de l'argile pressée dans des formes établies, séchée et cuite, des briques de divers ornements architecturaux utilisés dans la construction sont créées. La collection Homey s'inspire de ces formes de briques et propose une structure en briques aussi bien en version naturelle qu'en émail brillant.

7

Colori
Colours
Farben
Couleurs

Chalk



Taupe



Cotto



Cloudy

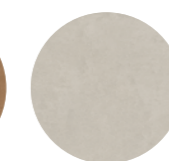

Dove

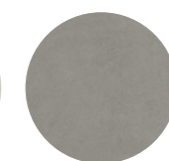

Sage

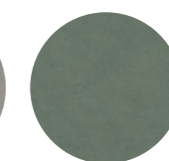

Berry



4

Formati
Sizes
Formate
Formats

120×120
48"×48"



60×120
24"×48"



60×60
24"×24"



10×60
4"×24"



1

Superfici
Surfaces
Oberflächen
Surfaces

Naturale

2

Strutture 3D
3D structures
Strukturen
Décorations en relief

30×60
12"×24"



8

Colori
Colours
Farben
Couleurs

Stripes
Glossy



Stripes
Mat



60×120
24"×48"



6

Colori
Colours
Farben
Couleurs

Canneté
Mat

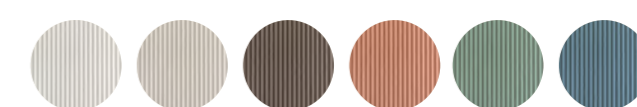

i

Effetto Contemporaneo
Contemporary effect
Moderne Wirkung
Effet Contemporain

Rivestimento
Wall Tiles
Wandfliesen
Revêtement

Pavimento
Floor Tiles
Bodenfliesen
Sol

Gres fine porcellanato ad impasto colorato
Coloured-body fine porcelain stoneware
Feinsteinzeug aus farbiger Masse
Grès cérame fin à pâte colorée

Tecnologia digitale
Digital technology
Digital technologie
Technologie numérique



WATCH THE VIDEO



Chalk

Per un risultato di posa ottimale si consiglia di prelevare le piastrelle da 5/6 scatole contemporaneamente.

For best installation results, we suggest taking the tiles from 5/6 boxes at the same time.



120x120
05245 | Homey Chalk Nat/Ret



60x120
05216 | Homey Chalk Nat/Ret



60x60
05224 | Homey Chalk Nat/Ret



60x120
05243 | Homey Rammed Cold Nat/Ret
(mix 9 graphics)



60x120
05276 | Homey Bloom White Nat/Ret
(mix 6 graphics)



10x60 - 4"x24"
05277 | Homey Chalk Nat/Ret



60x120
05244 | Homey Rammed Warm Nat/Ret
(mix 9 graphics)



Posa corretta / Correct laying

* Per la continuità di posa, si consiglia il verso della grafica come da minimale a catalogo
For continuity of installation, we recommend the direction of the graphics as per picture in the catalogue
Für eine kontinuierliche Verlegung empfehlen wir die Verlegung gemäß der Abbildung im Katalog
Pour la continuité de l'installation, nous recommandons la direction des graphiques selon les détournés du catalogue

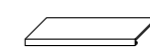
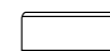



Taupe

Per un risultato di posa ottimale si consiglia di prelevare le piastrelle da 5/6 scatole contemporaneamente.

For best installation results, we suggest taking the tiles from 5/6 boxes at the same time.



120x120

05248 | Homey Taupe Nat/Ret



60x120

05219 | Homey Taupe Nat/Ret



60x60

05227 | Homey Taupe Nat/Ret



60x120

05243 | Homey Rammed Cold Nat/Ret
(mix 9 graphics)

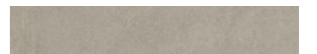

10x60

05280 | Homey Taupe Nat/Ret

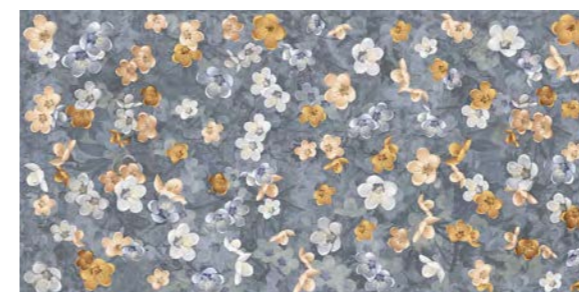

60x120

05275 | Homey Bloom Blue Nat/Ret
(mix 6 graphics)

* Per la continuità di posa, si consiglia il verso della grafica come da minimale a catalogo
For continuity of installation, we recommend the direction of the graphics as per picture in the catalogue
Für eine kontinuierliche Verlegung empfehlen wir die Verlegung gemäß der Abbildung im Katalog
Pour la continuité de l'installation, nous recommandons la direction des graphiques selon les détournés du catalogue



Posa corretta / Correct laying

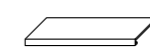
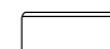



Cotto

Per un risultato di posa ottimale si consiglia di prelevare le piastrelle da 5/6 scatole contemporaneamente.

For best installation results, we suggest taking the tiles from 5/6 boxes at the same time.

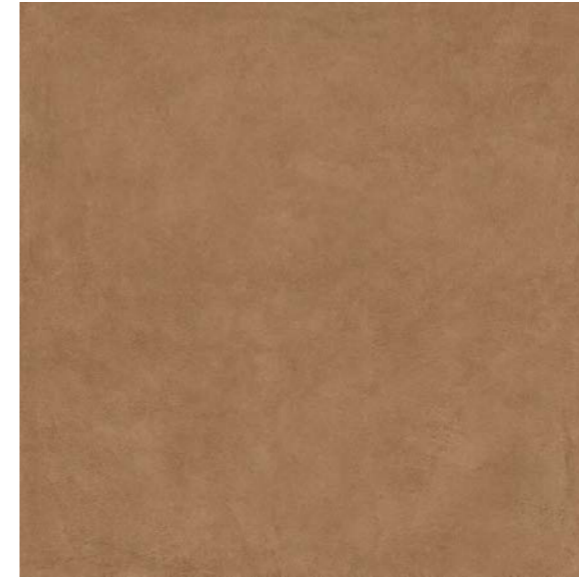

120x120
05249 | Homey Cotto Nat/Ret



60x120
05221 | Homey Cotto Nat/Ret



60x60
05228 | Homey Cotto Nat/Ret



60x120
***05244** | Homey Rammed Warm Nat/Ret
(mix 9 graphics)



10x60
05281 | Homey Cotto Nat/Ret



60x120
05241 | Homey Flower Cotto Nat/Ret

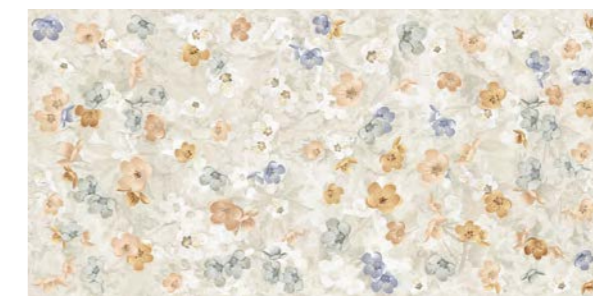

60x120
05276 | Homey Bloom White Nat/Ret
(mix 6 graphics)

* Per la continuità di posa, si consiglia il verso della grafica come da minimale a catalogo
For continuity of installation, we recommend the direction of the graphics as per picture in the catalogue
Für eine kontinuierliche Verlegung empfehlen wir die Verlegung gemäß der Abbildung im Katalog
Pour la continuité de l'installation, nous recommandons la direction des graphiques selon les détournés du catalogue



Cloudy

Per un risultato di posa ottimale si consiglia di prelevare le piastrelle da 5/6 scatole contemporaneamente.

For best installation results, we suggest taking the tiles from 5/6 boxes at the same time.

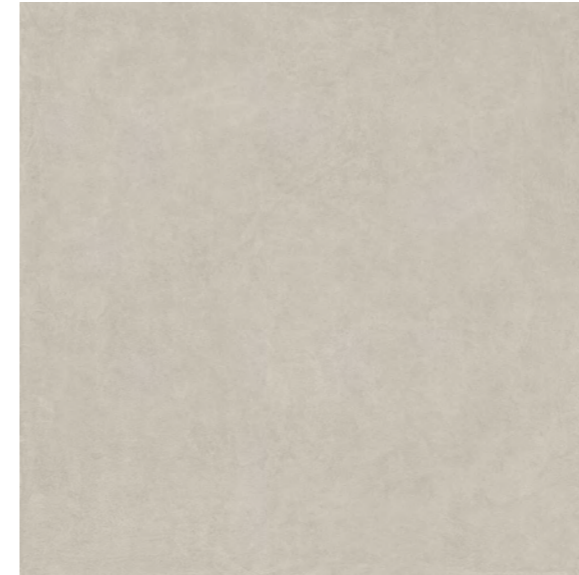

120x120
05246 | Homey Cloudy Nat/Ret

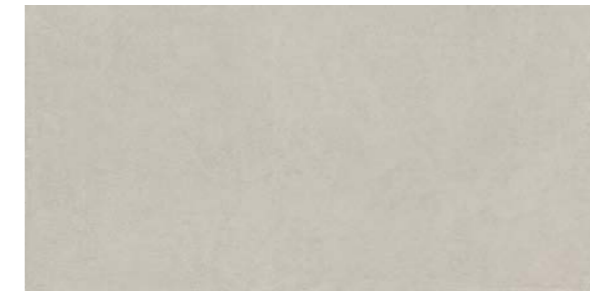

60x120
05217 | Homey Cloudy Nat/Ret



60x60
05225 | Homey Cloudy Nat/Ret



60x120
***05243** | Homey Rammed Cold Nat/Ret
(mix 9 graphics)



10x60
05278 | Homey Cloudy Nat/Ret



60x120
05275 | Homey Bloom Blue Nat/Ret
(mix 6 graphics)

* Per la continuità di posa, si consiglia il verso della grafica come da minimale a catalogo
For continuity of installation, we recommend the direction of the graphics as per picture in the catalogue
Für eine kontinuierliche Verlegelinie empfehlen wir die Verlegung gemäß der Abbildung im Katalog
Pour la continuité de l'installation, nous recommandons la direction des graphiques selon les détournés du catalogue

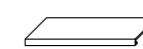
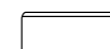



Dove

Per un risultato di posa ottimale si consiglia di prelevare le piastrelle da 5/6 scatole contemporaneamente.

For best installation results, we suggest taking the tiles from 5/6 boxes at the same time.

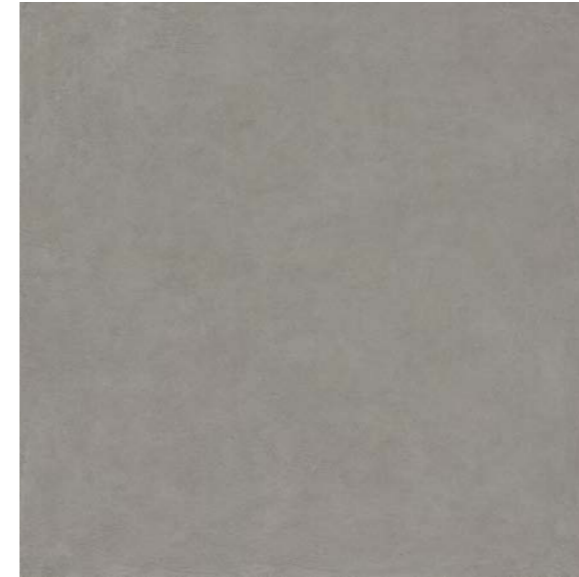

120x120
05247 | Homey Dove Nat/Ret



60x120
05218 | Homey Dove Nat/Ret



60x60
05226 | Homey Dove Nat/Ret



60x120
***05243** | Homey Rammed Cold Nat/Ret
(mix 9 graphics)

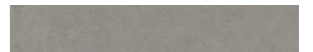

10x60
05279 | Homey Dove Nat/Ret



60x120
05242 | Homey Flower Chalk Nat/Ret

* Per la continuità di posa, si consiglia il verso della grafica come da minimale a catalogo
For continuity of installation, we recommend the direction of the graphics as per picture in the catalogue
Für eine kontinuierliche Verlegung empfehlen wir die Verlegung gemäß der Abbildung im Katalog
Pour la continuité de l'installation, nous recommandons la direction des graphiques selon les détournés du catalogue



Sage

Per un risultato di posa ottimale si consiglia di prelevare le piastrelle da 5/6 scatole contemporaneamente.

For best installation results, we suggest taking the tiles from 5/6 boxes at the same time.



60x120
05222 | Homey Sage Nat/Ret



60x60
05229 | Homey Sage Nat/Ret



10x60
05282 | Homey Sage Nat/Ret



60x120
*05243 | Homey Rammed Cold Nat/Ret
(mix 9 graphics)



60x120
05276 | Homey Bloom White Nat/Ret
(mix 6 graphics)



Berry



60x120
05223 | Homey Berry Nat/Ret

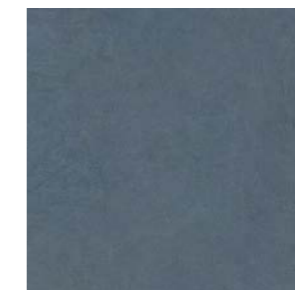

60x60
05231 | Homey Berry Nat/Ret



10x60
05283 | Homey Berry Nat/Ret



60x120
05241 | Homey Flower Cotto Nat/Ret

* Per la continuità di posa, si consiglia il verso della grafica come da minimale a catalogo
For continuity of installation, we recommend the direction of the graphics as per picture in the catalogue
Für eine kontinuierliche Verlegung empfehlen wir die Verlegung gemäß der Abbildung im Katalog
Pour la continuité de l'installation, nous recommandons la direction des graphiques selon les détournés du catalogue



Stripes Glossy



30x60
05234 | Stripes White Glossy Ret



30x60
05235 | Stripes Mustard Glossy Ret

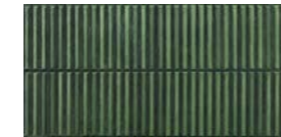

30x60
05233 | Stripes Green Glossy Ret



30x60
05232 | Stripes Blue Glossy Ret

Stripes Mat



30x60
05236 | Stripes White Mat Ret



30x60
05237 | Stripes Powder Mat Ret



30x60
05238 | Stripes Clay Mat Ret



30x60
05239 | Stripes Grey Mat Ret

Abbinabilità

Matching
Passende Kombinationen
Coloris Compatibles

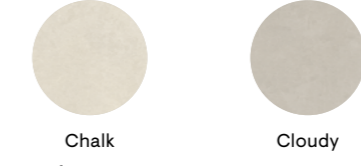
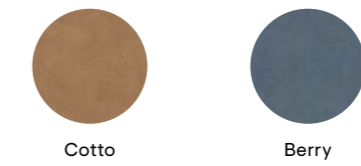
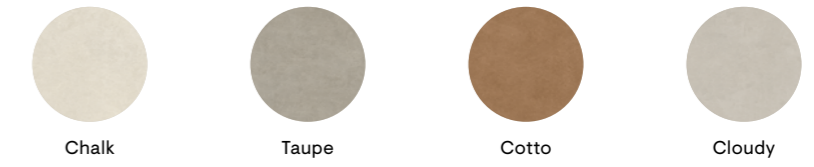

Solorovere

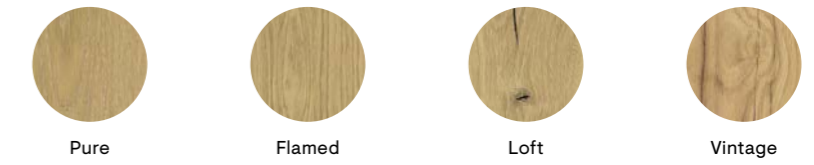



Canneté



60x120
05981 | Homey Canneté
Cotton Ret



60x120
05982 | Homey Canneté
Hemp Ret

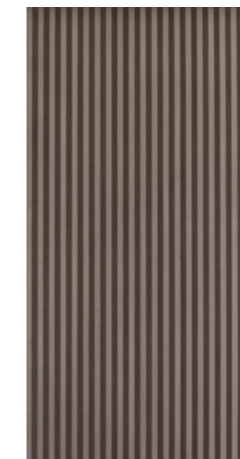

60x120
05986 | Homey Canneté
Shadow Ret

Abbinabilità

Matching
Passende Kombinationen
Coloris Compatibles



Cotto Dove Sage Berry



Chalk Cotto Berry



Chalk Cloudy

Solorovere



Pure Flamed Loft Vintage

Canneté



60x120
05983 | Homey Canneté
Rose Ret

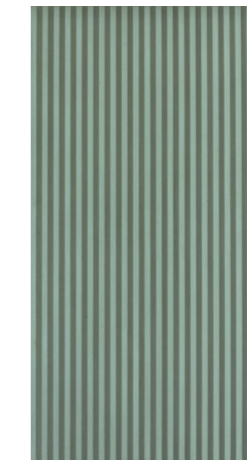

60x120
05984 | Homey Canneté
Laurel Ret

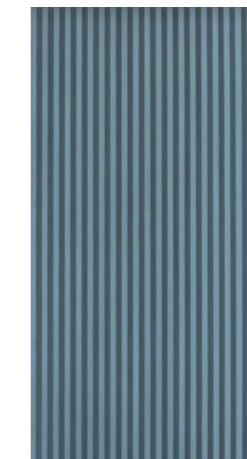

60x120
05985 | Homey Canneté
Denim Ret

Abbinabilità

Matching
Passende Kombinationen
Coloris Compatibles



Chalk Dove

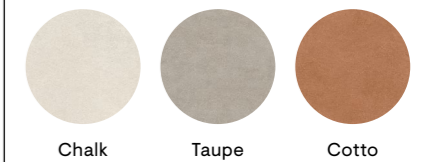

Chalk Taupe Cotto



Chalk Taupe Cotto Cloudy

Solorovere



Pure Flamed Loft Vintage

Packing
Verpackung
Emballage

Formati Sizes		± MM	Pezzi Scatola Pieces/Box Stck/Karton Carreaux/Boîte	Mq/Scatola Sqmt/Box Qm/Karton M2/Boîte	Kg/Scatola Kgs/Box Kg/Karton Kg/Boîte	Scatole/Paletta Boxes/Pallet Karton/Palette Boîte/Palette	Mq/Paletta Sqmt/Pallet Qm/Pallet M2/Palette	Kg/Paletta Kgs/Pallet Kg/Pallet Kg/Palette	Formato Paletta Size Pallet Format Pallet Dim. Palette
120x120 (48"x48") Nat/Ret	P	9,5	2	2,880	58,00	22	63,36	1276,00	135x122x68
60x120 (24"x48") Nat/Ret	P	9,5	2	1,440	31,00	30	43,20	930,00	122x82x75
60x60 (24"x24") Nat/Ret	P	9,5	4	1,440	29,00	32	46,08	928,00	120x80x75
10x60 (4"x24") Nat/Ret	P	9,5	10	0,600	12,50	72	43,20	900,00	120x80x75
30x60 (12"x24") Stripes Nat/Ret	P	9,5	7	1,260	26,30	32	40,32	841,60	120x80x75
60x120 (24"x48") Canneté Ret	P	9,5	1	0,720	15,50	60	43,20	930,00	122x82x75
60x120 (24"x48") Rammed Nat/Ret	P	9,5	2	1,440	31,00	30	43,20	930,00	122x82x75
60x120 (24"x48") Bloom Nat/Ret	P	9,5	2	1,440	31,00	30	43,20	930,00	122x82x75
60x120 (24"x48") Flower Nat/Ret	P	9,5	2	1,440	31,00	30	43,20	930,00	122x82x75
Pezzi Speciali / Special Pieces									
33x120 (13"x48") Gradino Costa Retta Nat/Ret	P	9,5	2	0,792	18,50	20	-	-	-
4,5x60 (1¾"x24") Battiscopa Nat/Ret	P	9,5	14	0,378 m.l. 8,40	8,00	80	-	-	-

Riepilogo Gamma

Collection
Serie
Gamme







	120x120 48"x48"	60x120 24"x48"	60x60 24"x24"	10x60 4"x24"	DIN 51130	DIN 51097	DCOF	ISEN 7976-2	AS 4586 2013	Stucchi Consigliati Recommended grouts Joints recommandés Empfohlene Fugen							
	± 9,5	± 9,5	± 9,5	± 9,5							± 9,5	± 9,5	± 9,5	± 9,5	± 9,5	± 9,5	
Nat/Ret Chalk	05245	05216	05224	05277	V2	R10	B	>0.42	wet, dry >36	P3	Mapei 111		05242	05244	05243	05276	05275
Nat/Ret Taupe	05248	05219	05227	05280	V2	R10	B	>0.42	wet, dry >36	P3	50% Mapei 111 50% Mapei 112		05244	05243			05275
Nat/Ret Cotto	05249	05221	05228	05281	V2	R10	B	>0.42	wet, dry >36	P3	Mapei 142	05241		05244	05243	05276	
Nat/Ret Cloudy	05246	05217	05225	05278	V2	R10	B	>0.42	wet, dry >36	P3	Mapei 111			05243			05275
Nat/Ret Dove	05247	05218	05226	05279	V2	R10	B	>0.42	wet, dry >36	P3	Mapei 112		05242		05243	05276	05275
Nat/Ret Sage		05222	05229	05282	V2	R10	B	>0.42	wet, dry >36	P3	Kerakoll 19		05242			05276	
Nat/Ret Berry		05223	05231	05283	V2	R10	B	>0.42	wet, dry >36	P3	Kerakoll 16	05241					

Stucchi Consigliati
Recommended grouts
Joints recommandés
Empfohlene Fugen

Kerakoll 34	Mapei 111	Mapei 133	Mapei 111	Mapei 111	Kerakoll 14
-------------	-----------	-----------	-----------	-----------	-------------

Riepilogo Gamma

Collection
Serie
Gamme

	Strutture 3D 3D Structures								Pezzi Speciali Special Pieces	
	Stripes White Glossy 30*60 12"*24"	Stripes Mustard Glossy 30*60 12"*24"	Stripes Green Glossy 30*60 12"*24"	Stripes Blue Glossy 30*60 12"*24"	Stripes White Mat 30*60 12"*24"	Stripes Powder Mat 30*60 12"*24"	Stripes Clay Mat 30*60 12"*24"	Stripes Grey Mat 30*60 12"*24"	Gradino Costa Retta 33*120 13"*48"	Battiscopa 4,5*60 1¾"*24"
	€ 9,5	€ 9,5	€ 9,5	€ 9,5	€ 9,5	€ 9,5	€ 9,5	€ 9,5	€ 9,5	
 Nat/Ret Chalk			05233	05232			05238	05239	05264	05256
 Nat/Ret Taupe	05234	05235	05233	05232	05236				05267	05259
 Nat/Ret Cotto	05234		05233	05232		05237	05238		05268	05261
 Nat/Ret Cloudy				05232	05236			05239	05265	05257
 Nat/Ret Dove	05234	05235			05236				05266	05258
 Nat/Ret Sage	05234				05236		05238		05269	05262
 Nat/Ret Berry	05234	05235			05236	05237	05238		05271	05263

Stucchi Consigliati Recommended grouts Joints recommandés Empfohlene Fugen
Mapei 111 Kerakoll 30 50% Kerakoll 19 50% Mapei 120 Kerakoll 16 Mapei 111 Mapei 141 Kerakoll 34 Mapei 112







Riepilogo Gamma

Collection
Serie
Gamme

CLICK



PDF Merchandising

	Strutture 3D 3D Structures					
	Canneté Cotton 60*120 24"*48"	Canneté Hemp 60*120 24"*48"	Canneté Shadow 60*120 24"*48"	Canneté Rose 60*120 24"*48"	Canneté Laurel 60*120 24"*48"	Canneté Denim 60*120 24"*48"
	€ 9,5	€ 9,5	€ 9,5	€ 9,5	€ 9,5	€ 9,5
 Nat/Ret Chalk		05982	05986	05983	05984	05985
 Nat/Ret Taupe	05981				05984	05985
 Nat/Ret Cotto	05981	05982			05984	05985
 Nat/Ret Cloudy			05986			05985
 Nat/Ret Dove	05981			05983		
 Nat/Ret Sage	05981					
 Nat/Ret Berry	05981	05982				

Stucchi Consigliati Recommended grouts Joints recommandés Empfohlene Fugen
Mapei 103 Mapei 123 Mapei 119 50% Kerakoll 40 50% Mapei 110 Kerakoll 19 Kerakoll 15

Materia

Materia nasce dall'idea sviluppata in Piemme per una nuova espressione della ceramica, una materia nobile con una grande storia creativa che ritrova e rilancia il proprio estro originario e, grazie alla sua tecnica grafica, analizza l'estetica di materie differenti, come il metallo, la pietra e la ceramica stessa.

Materia is conceived to introduce a new expression of ceramics. A noble material with a great history relaunches its creative potential thanks to the graphic technique and the diverse esthetics of materials like metal, stone and ceramics itself.

Mit „Materia“ möchte Piemme der Keramik einen neuen Ausdruck verleihen. Das edle und geschichtsträchtige Material findet zurück zu seinen Wurzeln, erfindet sich neu und analysiert mit seiner graphischen Technik seine eigene Ästhetik sowie die anderer Materialien wie Metall und Stein.

« Materia » est l'aboutissement d'une idée développée par Piemme: donner à la céramique, matière noble, riche d'une histoire nourrie de créativité, une nouvelle forme d'expression où elle puisse retrouver son style originel. Ses techniques graphiques lui permettent d'analyser les dimensions esthétiques de matières comme le métal, la pierre ainsi que la céramique.

6

Colori
Colours
Farben
Couleurs

Opal



Shimmer



Nacre



Reflex



Rust

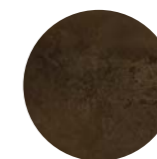

Deep

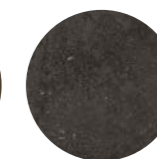

5

Formati
Sizes
Formate
Formats

120×120
48"×48"



60×120
24"×48"



90×90
36"×36"



60×60
24"×24"



30×60
12"×24"



3

Superfici
Surfaces
Oberflächen
Surfaces

Naturale Lappato Grip

2

Strutture 3D
3D structures
Strukturen
Decorations and relief

Tensegrity



Garage

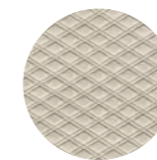

i

Effetto Contemporaneo
Contemporary effect
Moderne Wirkung
Effet Contemporain

Rivestimento
Wall Tiles
Wandfliesen
Revêtement

Pavimento
Floor Tiles
Bodenfliesen
Sol

Gres fine porcellanato ad impasto colorato
Coloured-body fine porcelain stoneware
Feinsteinzeug aus farbiger Masse
Grès cérame fin à pâte colorée

Tecnologia digitale
Digital technology
Digital Technologie
Technologie numérique

▶ WATCH THE VIDEO

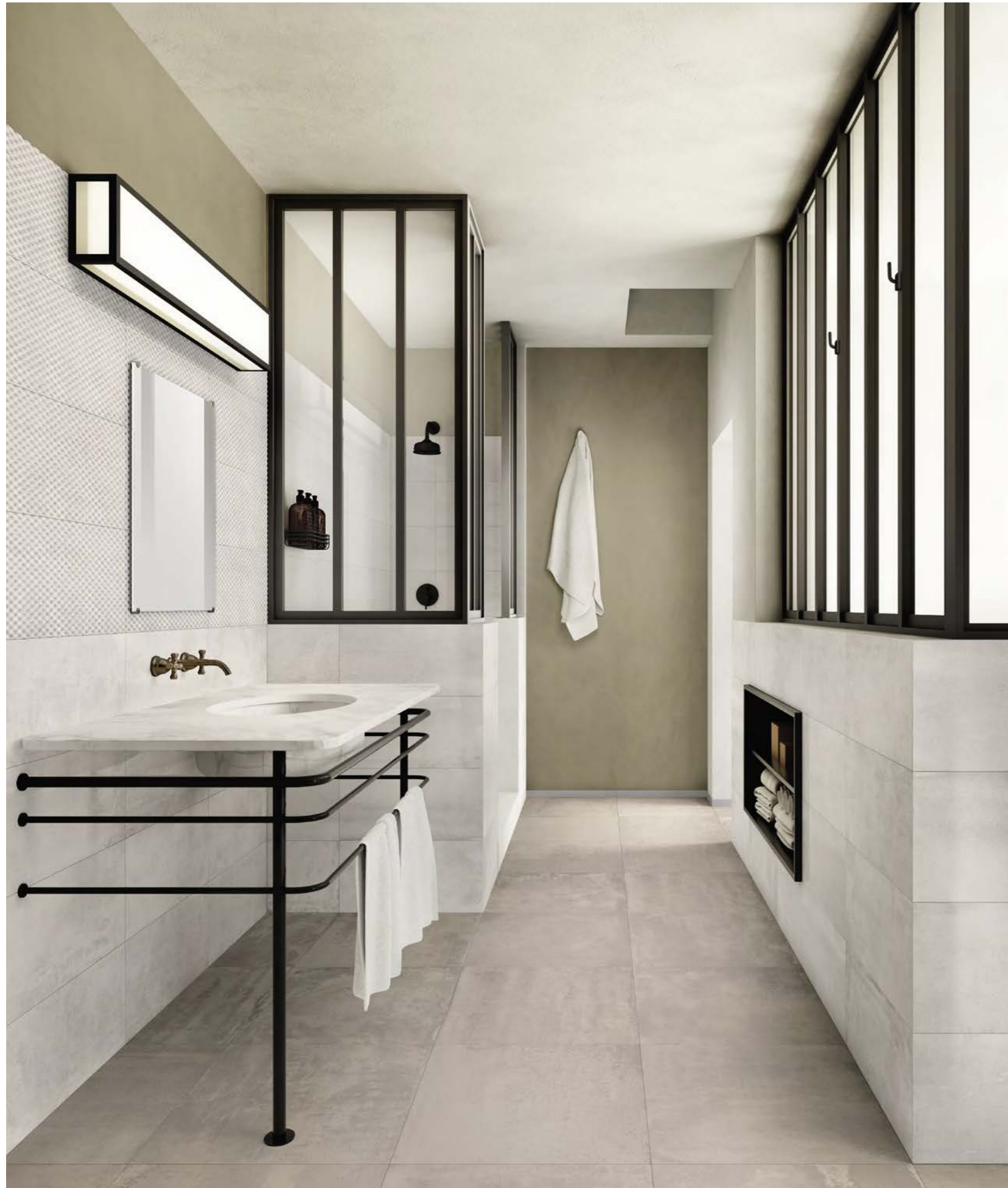

Opal



120x120

03071A | Materia Opal Nat/Ret
03075A | Materia Opal Lap/Ret



90x90

03468A | Materia Opal Nat/Ret
03473A | Materia Opal Lap/Ret



60x60

02847A | Materia Opal Nat/Ret
02853A | Materia Opal Lap/Ret



30x60

02827A | Materia Opal Nat/Ret
02834A | Materia Opal Lap/Ret



60x120

02859A | Materia Opal Nat/Ret
02866A | Materia Opal Lap/Ret



60x60

***02981A** | Materia Platinum Nat/Ret
(mix 4 graphics)

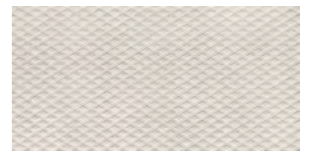

30x60

02936A | Materia Garage Opal Nat/Ret



30x60

03079A | Materia Tensegrity Opal Nat/Ret



30x120

***02944A** | Materia Raku Warm Nat/Ret
(handcrafted decor)

* Decori realizzati con smalti e metalli preziosi. Vedere nota a pag. 366-367
Decors made with glazes and precious metals. See note on pages 366-367
Dekore aus Glasuren und Edelmetallen. Siehe Hinweis auf Seiten 366-367
Décors réalisés avec des émaux et des métaux précieux. Voir note aux pages 366-367

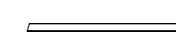
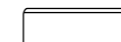



Shimmer



120x120

03072A | Materia Shimmer Nat/Ret
03076A | Materia Shimmer Lap/Ret



90x90

02982 | Materia Shimmer Grip/Ret ± 20mm



60x60

02849A | Materia Shimmer Nat/Ret
02855A | Materia Shimmer Lap/Ret



30x60

02829A | Materia Shimmer Nat/Ret
02838A | Materia Shimmer Lap/Ret



60x120

02862A | Materia Shimmer Nat/Ret
02868A | Materia Shimmer Lap/Ret



90x90

03469A | Materia Shimmer Nat/Ret
03474A | Materia Shimmer Lap/Ret



30x60

02938A | Materia Garage Shimmer Nat/Ret



30x120

***02944A** | Materia Raku Warm Nat/Ret
(handcrafted decor)



30x60

03082A | Materia Tensegrity Shimmer Nat/Ret



20x15

02989 | Soul Kaleido Light Nat/Ret

* Decori realizzati con smalti e metalli preziosi. Vedere nota a pag. 366-367
Decors made with glazes and precious metals. See note on pages 366-367
Dekore aus Glasuren und Edelmetallen. Siehe Hinweis auf Seiten 366-367
Décors réalisés avec des émaux et des métaux précieux. Voir note aux pages 366-367

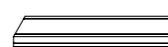
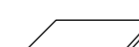
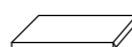
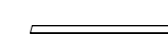
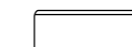



Nacre



60×120

02861A | Materia Nacre Nat/Ret
02867A | Materia Nacre Lap/Ret



60×60

02848A | Materia Nacre Nat/Ret
02854A | Materia Nacre Lap/Ret



60×60

***02980A** | Materia Gold Nat/Ret
(mix 4 graphics)



30×120

***02944A** | Materia Raku Warm Nat/Ret
(handcrafted decor)



30×60

02828A | Materia Nacre Nat/Ret
02836A | Materia Nacre Lap/Ret

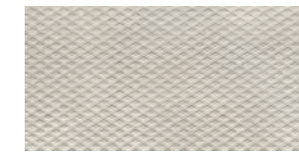

30×60

02937A | Materia Garage Nacre Nat/Ret



30×60

03081A | Materia Tensegrity Nacre Nat/Ret

* Decori realizzati con smalti e metalli preziosi. Vedere nota a pag. 366-367
Decors made with glazes and precious metals. See note on pages 366-367
Dekore aus Glasuren und Edelmetallen. Siehe Hinweis auf Seiten 366-367
Décors réalisés avec des émaux et des métaux précieux. Voir note aux pages 366-367

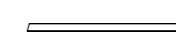
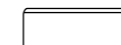



Reflex



60x120

02863A | Materia Reflex Nat/Ret
02869A | Materia Reflex Lap/Ret



90x90

02983 | Materia Reflex Grip/Ret ± 20mm



60x60

02850A | Materia Reflex Nat/Ret
02856A | Materia Reflex Lap/Ret



30x120

***02944A** | Materia Raku Warm Nat/Ret
(handcrafted decor)



30x60

02831A | Materia Reflex Nat/Ret
02841A | Materia Reflex Lap/Ret

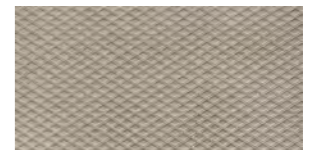

30x60

02939A | Materia Garage Reflex Nat/Ret



30x60

03083A | Materia Tensegrity Reflex Nat/Ret

* Decori realizzati con smalti e metalli preziosi. Vedere nota a pag. 366-367
Decors made with glazes and precious metals. See note on pages 366-367
Dekore aus Glasuren und Edelmetallen. Siehe Hinweis auf Seiten 366-367
Décors réalisés avec des émaux et des métaux précieux. Voir note aux pages 366-367

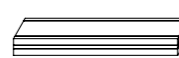
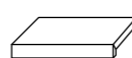
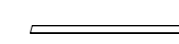
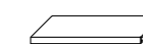
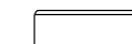



Rust



120x120

03073A | Materia Rust Nat/Ret
03077A | Materia Rust Lap/Ret



90x90

03471A | Materia Rust Nat/Ret
03475A | Materia Rust Lap/Ret



60x60

02851A | Materia Rust Nat/Ret
02857A | Materia Rust Lap/Ret



30x60

02832A | Materia Rust Nat/Ret
02843A | Materia Rust Lap/Ret



60x120

02864A | Materia Rust Nat/Ret
02871A | Materia Rust Lap/Ret

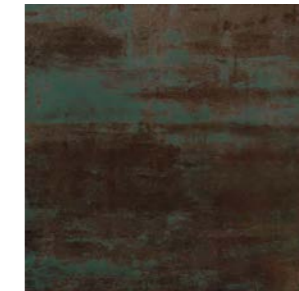

60x60

***02945A** | Materia Jade Nat/Ret
(mix 4 graphics)



30x60

02941A | Materia Garage Rust Nat/Ret



30x60

03084A | Materia Tensegrity Rust Nat/Ret



30x120

***02944A** | Materia Raku Warm Nat/Ret
(handcrafted decor)



20x15

02990 | Soul Kaleido Dark Nat/Ret

* Decori realizzati con smalti e metalli preziosi. Vedere nota a pag. 366-367
Decors made with glazes and precious metals. See note on pages 366-367
Dekore aus Glasuren und Edelmetallen. Siehe Hinweis auf Seiten 366-367
Décors réalisés avec des émaux et des métaux précieux. Voir note aux pages 366-367

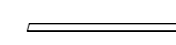
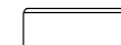



Deep



120x120
03074A | Materia Deep Nat/Ret
03078A | Materia Deep Lap/Ret



60x120
02865A | Materia Deep Nat/Ret
02872A | Materia Deep Lap/Ret



30x120
***02943A** | Materia Raku Cold Nat/Ret
(handcrafted decor)



90x90
02984 | Materia Deep Grip/Ret \pm 20mm



90x90
03472A | Materia Deep Nat/Ret
03476A | Materia Deep Lap/Ret

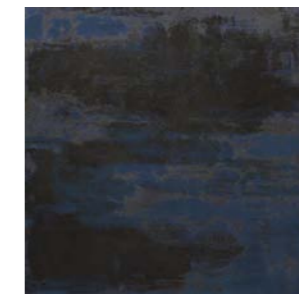

60x60
***02946A** | Materia Zaphire Nat/Ret
(mix 4 graphics)



60x60
02852A | Materia Deep Nat/Ret
02858A | Materia Deep Lap/Ret



30x60
02833A | Materia Deep Nat/Ret
02846A | Materia Deep Lap/Ret

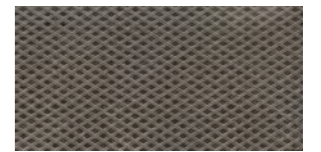

30x60
02942A | Materia Garage Deep Nat/Ret

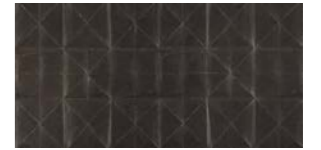

30x60
03085A | Materia Tensegrity Deep Nat/Ret

* Decori realizzati con smalti e metalli preziosi. Vedere nota a pag. 366-367
Decors made with glazes and precious metals. See note on pages 366-367
Dekore aus Glasuren und Edelmetallen. Siehe Hinweis auf Seiten 366-367
Décors réalisés avec des émaux et des métaux précieux. Voir note aux pages 366-367

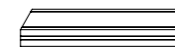
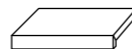
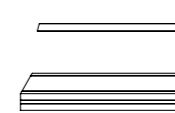
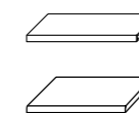
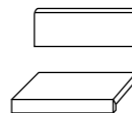

Packing
Verpackung
Emballage















Formati Sizes	P	± MM							
			Pezzi Scatola Pieces/Box Stck/Karton Carreaux/Boite	Mq/Scatola Sqmt/Box Qm/Karton M2/Boite	Kg/Scatola Kgs/Box Kg/Karton Kg/Boite	Scatole/Paletta Boxes/Pallet Karton/Palette Boite/Palette	Mq/Paletta Sqmt/Pallet Qm/Pallet M2/Palette	Kg/Paletta Kgs/Pallet Kg/Pallet Kg/Palette	Formato Paletta Size Pallet Format Pallet Dim. Palette
120x120 (48"x48") Nat/Ret - Lap/Ret	P	9,5	2	2,88	58,00	22	63,36	1276	135x122x68
90x90 (36"x36") Grip/Ret	P	20	1	0,81	36,50	30	24,30	1095	107x94x60
90x90 (36"x36") Nat/Ret - Lap/Ret	P	9,5	2	1,620	36,50	20	32,40	730	107x94x60
60x120 (24"x48") Nat/Ret	P	9,5	2	1,44	31,00	30	43,20	930	122x82x75
60x120 (24"x48") Lap/Ret	P	9,5	2	1,44	32,00	30	43,20	960	122x82x75
60x60 (24"x24") Nat/Ret	P	9,5	4	1,44	29,00	32	46,08	928	120x80x75
60x60 (24"x24") Lap/Ret	P	9,5	4	1,44	30,00	32	46,08	960	120x80x75
30x60 (12"x24") Nat/Ret	P	9,5	7	1,26	25,30	40	50,4	1012	120x80x75
30x60 (12"x24") Lap/Ret	P	9,5	7	1,26	26,30	40	50,4	1052	120x80x75
30x120 (12"x48") Raku Nat/Ret	P	9,5	2	0,72	15,50	30	21,60	465	122x96x70
60x60 (24"x24") Jade - Zaphire - Gold - Platinum Nat/Ret	P	9,5	2	0,72	14,50	32	23,04	464	120x80x75
30x60 (12"x24") Garage Nat/Ret	P	9,5	7	1,26	25,30	32	40,32	809,6	120x80x75
30x60 (12"x24") Tensegrity Nat/Ret	P	9,5	7	1,26	25,30	32	40,32	809,6	120x80x75
20x15 (8"x6") Kaleido Nat/Ret	P	9,5	25	0,750	15,50	36	-	-	-
Pezzi Speciali / Special Pieces									
33x120 (13"x48") Gradino Costa Retta Nat/Ret - Lap/Ret	P	9,5	2	0,792	18,50	20	-	-	-
4,5x60 (1 1/4"x24") Battiscopa Nat/Ret - Lap/Ret	P	9,5	14	0,378	8,00	80	-	-	-
1,5x120 (3/4"x48") Bacchetta Jolly Nat/Ret - Lap/Ret	P	9,5	6	0,108	2,50	48	-	-	-
1,5x1,5 (3/4"x3/4") Unghia Jolly Nat/Ret - Lap/Ret	P	9,5	6	0,001	0,50	48	-	-	-
33x90 (13"x36") Gradone Grip/Ret	P	20	2	0,594	27,00	36	-	-	-
30x90 (12"x36") Elemento L Grip/Ret	P	20	2	0,54	28,50	27	-	-	-
18x90 (7 1/4"x36") Griglia Scolo Grip/Ret	P	20	1	0,162	7,50	48	-	-	-

Collection
Serie
Gamme

Formati Sizes	P	± MM											
			120x120 48"x48"	90x90 36"x36"	90x90 36"x36"	60x120 24"x48"	60x60 24"x24"	30x60 12"x24"	DIN 51130	DIN 51097	DCOF		
			± 9,5	± 20	± 9,5	± 9,5	± 9,5	± 9,5					
Opal	Nat/Ret		03071A		03468A	02859A	02847A	02827A	V2	R10	A+B	>0.42	
	Lap/Ret		03075A		03473A	02866A	02853A	02834A					
Shimmer	Nat/Ret		03072A		03469A	02862A	02849A	02829A	V2	R10	A+B	>0.42	
	Lap/Ret		03076A		03474A	02868A	02855A	02838A					
	Grip/Ret			02982						R11	A+B+C	>0.42	
Nacre	Nat/Ret					02861A	02848A	02828A	V2	R10	A+B	>0.42	
	Lap/Ret					02867A	02854A	02836A					
Reflex	Nat/Ret					02863A	02850A	02831A	V2	R10	A+B	>0.42	
	Lap/Ret					02869A	02856A	02841A					
	Grip/Ret			02983						R11	A+B+C	>0.42	
Rust	Nat/Ret		03073A		03471A	02864A	02851A	02832A	V2	R10	A+B	>0.42	
	Lap/Ret		03077A		03475A	02871A	02857A	02843A					
Deep	Nat/Ret		03074A		03472A	02865A	02852A	02833A	V2	R10	A+B	>0.42	
	Lap/Ret		03078A		03476A	02872A	02858A	02846A					
	Grip/Ret			02984						R11	A+B+C	>0.42	











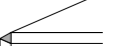

Riepilogo Gamma

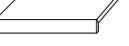
Collection
Serie
Gamme

	Formati Sizes	Strutture 3D 3D Structures									
											
		Tensegrity 30*60 12"*24"	Garage 30*60 12"*24"	Platinum 60*60 24"*24"	Gold 60*60 24"*24"	Jade 60*60 24"*24"	Zaphire 60*60 24"*24"	Raku 30*120 12"*48"	Kaleido 20*15 8"*6"		
		± 9,5	± 9,5	± 9,5	± 9,5	± 9,5	± 9,5	± 9,5	± 9,5		
 Opal	Nat/Ret	03079A	02936A	02981A				02944A			
 Shimmer	Nat/Ret	03082A	02938A					02944A	02989		
 Nacre	Nat/Ret	03081A	02937A		02980A			02944A			
 Reflex	Nat/Ret	03083A	02939A					02944A			
 Rust	Nat/Ret	03084A	02941A			02945A		02944A	02990		
 Deep	Nat/Ret	03085A	02942A				02946A	02943A			

Riepilogo Gamma

Collection
Serie
Gamme

	Formati Sizes	Pezzi Speciali Special Pieces						
								
		Gradino Costa Retta 33*120 13"*48"	Battiscopa 4,5*60 1 1/4"*24"	Bacchetta Jolly 1,5*120 5/8"*48"	Unghia Jolly 1,5*1,5 5/8"*5/8"	Gradone 33*90 13"*36"	Elemento L 30*90 12"*36"	Griglia Scolo 18*90 7 1/4"*36"
		± 9,5	± 9,5	± 9,5	± 9,5	± 20	± 20	± 20
 Opal	Nat/Ret	03097A	02893	03111A	03124			
	Lap/Ret	03104A	02899	03117A	03131			
 Shimmer	Nat/Ret	03099A	02895	03113A	03126			
	Lap/Ret	03106A	02902	03119A	03133			
	Grip/Ret					03137	03141	03149
 Nacre	Nat/Ret	03098A	02894	03112A	03125			
	Lap/Ret	03105A	02901	03118A	03132			
 Reflex	Nat/Ret	03101A	02896	03114A	03127			
	Lap/Ret	03107A	02903	03121A	03134			
	Grip/Ret					03138	03142	03151
 Rust	Nat/Ret	03102A	02897	03115A	03128			
	Lap/Ret	03108A	02904	03122A	03135			
 Deep	Nat/Ret	03103A	02898	03116A	03129			
	Lap/Ret	03109A	02905	03123A	03136			
	Grip/Ret					03139	03143	03152

Pezzi Speciali su Richiesta - Special pieces upon request
Formstücke auf Anfrage - Pièces spéciales sur demande



Gradone Angolare Sx/Dx 20 mm
Grip/Ret 33*90 - 13"*36" ± 20



Griglia Scolo Angolare Sx/Dx 20 mm
Grip/Ret 18*90 - 7 1/4"*36" ± 20

Fragments

Designed by Pierre Charpin

Proprio come i "frammenti di un discorso amoroso" la collezione disegnata da Pierre Charpin per Ceramiche Piemme insegue il movimento, non ha trama, se non quella dell'indagine sul linguaggio delle forme.

Just like the "fragments of a lover's discourse" the collection designed by Pierre Charpin for Ceramiche Piemme follows movement and has no plot except for the investigation into the language of shapes.

Ebenso wie die "fragmente einer sprache der liebe" folgt die von Pierre Charpin für Ceramiche Piemme entworfene kollektion der Bewegung, ohne feste Struktur ausser jener einer Untersuchung der Formensprache.

A la manière des "fragments d'un discours amoureux", la collection dessinée par Pierre Charpin pour Ceramiche Piemme épouse le mouvement ; elle n'a pas de trame si ce n'est l'analyse du langage des formes.

6

Colori
Colours
Farben
Couleurs

Maiolica Milk

Maiolica Cloud

Maiolica Tan

Maiolica Fern

Maiolica Ocean

Maiolica Charcoal

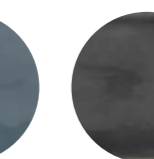
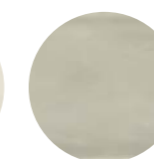

1

Formati
Sizes
Formate
Formats

7,5x30

3"x12"

1

1

Superfici
Surfaces
Oberflächen
Surfaces

Naturale

i

Effetto Contemporaneo
Contemporary effect
Moderne Wirkung
Effet Contemporain

Rivestimento
Wall Tiles
Wandfliesen
Revêtement

Pasta Bianca
White Body
Weißscherbisig
Pâte Blanche

Tecnologia digitale
Digital technology
Digital Technologie
Technologie numérique

Maiolica Milk



Maiolica Fern



Maiolica Cloud



Maiolica Ocean

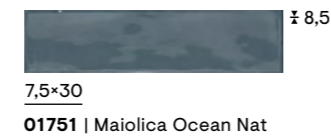

Maiolica Tan



Maiolica Charcoal

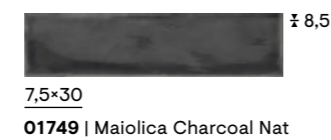

Imballi

Packing
Verpackung
Emballage

Formato / Size		± MM	Pezzi Scatola Pcs/Box Stck/Karton Carreaux/Boîtes	Mq/Scatola Sqmt/Box M2/Karton Qm/Boîtes	Kg/Scatola Kgs/Box Kg/Karton Kg/Boîtes	Scatola/Paletta Boxes/Pallet Karton/Palette Boîtes/Pallet	Mq/Paletta Sqmt/Pallet M2/Palette Qm/Pallet	Kg/Paletta Kgs/Pallet Kg/Palette Kg/Pallet	Formato Paletta Size Pallet Format Palette Dim. Palette
7,5x30 (3"x12") Nat	PB	8,5	22	0,50	7,29	120	60	875	120x80x75

Riepilogo Gamma

Collection
Serie
Gamme

	Formati Sizes		
	Nat	7,5x30 3"x12" ± 8,5	
Milk			
	Nat	01746	V2
Cloud			
	Nat	01747	V2
Tan			
	Nat	01748	V2
Fern			
	Nat	01752	V2
Ocean			
	Nat	01751	V2
Charcoal			
	Nat	01749	V2
Charcoal			

CERAMICHE PIEMME

CONTRACT

CLICK



Ceramiche Piemme propone la gamma "Contract": una linea di prodotti versatile ed essenziale, dedicata sia agli ambienti residenziali che pubblici ad alta frequentazione. La gamma "Contract" unisce una ricerca estetica sobria ad elevate caratteristiche tecniche e prestazionali, per supportare il progettista nella scelta delle finiture in tutti gli spazi della quotidianità, pubblica e privata.

Ceramiche Piemme presents its "Contract" range: a versatile line of products. Designed for both residential and busy public environments, the "Contract" range combines a sober aesthetic style with superior technical characteristics and performances, to support the designer in choosing the finishes for all the public and private spaces of contemporary everyday life.

Ceramiche Piemme präsentiert die Linie "Contract": Eine vielseitige Produktpalette, die sich an den Wohnungsbau ebenso wie an vielbesuchte öffentliche Bereiche wendet. Sie vereint eine schlichte Optik mit hohen technischen Eigenschaften und Leistungen, die den Planer in der Wahl der Oberflächen für alle - öffentlichen wie privaten - Räume des täglichen Lebens unterstützt.

Ceramiche Piemme présente sa collection « Contract » : une collection de produits polyvalents, faite pour les cadres résidentiels et publics très fréquentés. La collection « Contract » conjugue une esthétique sobre avec une très grande performance technique pour que le designer choisisse en toute liberté les finitions pour tous les espaces du quotidien, publics comme privés.

STONE EFFECT

330 [Ardesia 2.0](#) CONTRACT /

CEMENT EFFECT

334 [Opus](#) CONTRACT /

340 [Suprema](#) CONTRACT /

344 [Concrete](#) CONTRACT /

CONTEMPORARY

352 [Venetian Marble](#) CONTRACT

Artdesia 2.0

Artdesia 2.0: una collezione, ispirata alle rocce sedimentarie, in grado di rispondere al meglio alle esigenze di architetti e progettisti alla ricerca di una estetica minimale caratterizzata da una eleganza senza tempo.

Artdesia 2.0: a collection, inspired by sedimentary rocks, that best meets the needs of architects and designers looking for a minimalist design characterized by a timeless elegance.

Artdesia 2.0: eine vom Schiefer-Stein inspirierte Kollektion, die den Bedürfnissen von Architekten und Designern, die eine minimalistische Ästhetik mit zeitloser Eleganz suchen, am besten gerecht wird.

Artdesia 2.0: une collection inspirée des roches sédimentaires, capable de répondre au mieux aux besoins des architectes et designers à la recherche d'une esthétique minimale caractérisée par une élégance intemporelle.

5

Colori
Colours
Farben
Couleurs

Ivory



Sand



Silver

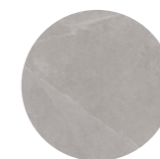

Grey

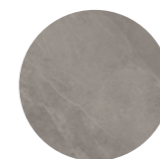

Black

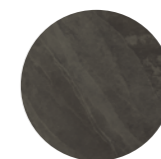

3

Formati
Sizes
Formate
Formats

60×120
24"×48"



60×60
24"×24"



30×60
12"×24"



3

Superfici
Surfaces
Oberflächen
Surfaces

Naturale

Antislip

Grip

i

Effetto Pietra
Stone Look
Natursteinoptik
Effet Pierre

Rivestimento
Wall Tiles
Wandfliesen
Revêtement

Pavimento
Floor Tiles
Bodenfliesen
Sol

Gres fine porcellanato ad impasto colorato
Coloured-body fine porcelain stoneware
Feinsteinzeug aus farbiger Masse
Grès cérame fin à pâte colorée

Tecnologia digitale
Digital technology
Digital Technologie
Technologie numérique

Ivory



60x120

04987 | Artdesia 2.0 Ivory Nat/Ret



60x60

04991 | Artdesia 2.0 Ivory Nat/Ret
05368 | Artdesia 2.0 Ivory Grip/Ret ± 20mm

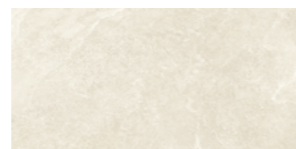

30x60

04994 | Artdesia 2.0 Ivory Nat/Ret



30x30

04998 | Mosaico Art Ivory Nat/Ret

Sand



60x120

05651 | Artdesia 2.0 Sand Nat/Ret
05659 | Artdesia 2.0 Sand Antislip/Ret



60x60

05649 | Artdesia 2.0 Sand Nat/Ret

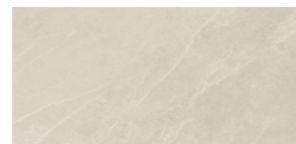

30x60

05647 | Artdesia 2.0 Sand Nat/Ret

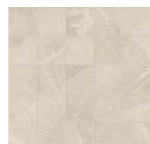

30x30

05653 | Mosaico Art Sand Nat/Ret

Silver

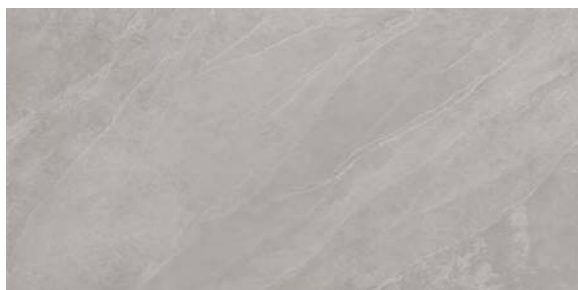

60x120

05652 | Artdesia 2.0 Silver Nat/Ret
05660 | Artdesia 2.0 Silver Antislip/Ret



60x60

05650 | Artdesia 2.0 Silver Nat/Ret



30x60

05648 | Artdesia 2.0 Silver Nat/Ret



30x30

05654 | Mosaico Art Silver Nat/Ret

Grey



60x120

04988 | Artdesia 2.0 Grey Nat/Ret



60x60

04992 | Artdesia 2.0 Grey Nat/Ret
05369 | Artdesia 2.0 Grey Grip/Ret ± 20mm



30x60

04995 | Artdesia 2.0 Grey Nat/Ret



30x30

04999 | Mosaico Art Grey Nat/Ret

Black



60x120

04989 | Artdesia 2.0 Black Nat/Ret

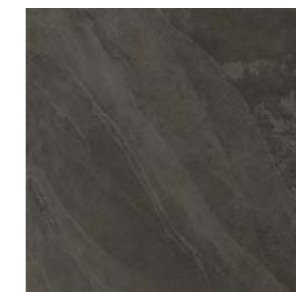

60x60

04993 | Artdesia 2.0 Black Nat/Ret

CLICK

PDF Merchandising



30x60

04996 | Artdesia 2.0 Black Nat/Ret

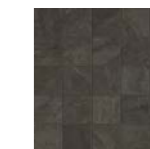

30x30

05000 | Mosaico Art Black Nat/Ret

Imballi

Packing
Verpackung
Emballage

Formati Sizes	± MM	Pezzi Pieces/Box Stck/Karton Carreaux/Boîte	Mq/Scatola Sqmt/Box Qm/Karton M2/Boîte	Kg/Scatola Kgs/Box Kg/Karton Kg/Boîte	Scatole/Paletta Boxes/Pallet Karton/Palette Boîte/Palette	Mq/Paletta Sqmt/Pallet Qm/Pallet M2/Palette	Kg/Paletta Kgs/Pallet Kg/Pallet Kg/Palette	Formato Paletta Size Pallet Format Pallet Dim. Palette	
60x120 (24"x48") Nat/Ret	P	8,5	2	1,44	28,00	36	51,84	1008	122x82x75
60x60 (24"x24") Nat/Ret	P	8,5	4	1,44	26,00	40	57,6	1040	122x82x75
60x60 (24"x24") Grip/Ret	P	20	2	0,72	31,40	30	21,6	942	120x80x75
30x60 (12"x24") Nat/Ret	P	8,5	7	1,26	22,50	48	60,48	1080	120x80x75
30x30 (12"x12") Mosaico Nat/Ret	P	8,5	5	0,45	8,50	60	-	-	-
4,5x60 (1½"x24") Battiscopa Nat/Ret	P	8,5	14	0,378	8,00	80	-	-	-
30x60 (12"x24") Step Nat/Ret	P	8,5	6	1,08	21,5	36	-	-	-

Riepilogo Gamma

Collection
Serie
Gamme

Formati Sizes	Pezzi Speciali Special Pieces	60x120 24"x48"	60x60 24"x24"	60x60 24"x24"	30x60 12"x24"	Din 51130			Din 51097			DCOF			Mosaico 30x30 - 12"x12"	Battiscopa 4,5x60 - 1½"x24"	Step 30x60 - 12"x24"	
		± 8,5	± 8,5	± 20	± 8,5													
Ivory	Nat/Ret	04987	04991		04994	V2	R10	A+B	>0.42	04998	05001	05004						
	Grip/Ret			05368			R11	A+B+C	>0.42									
Sand	Nat/Ret	05651	05649		05647	V2	R10	A+B	>0.42	05653	05655	05657						
	Antislip/Ret	05659					R11	A+B+C	>0.42									
Silver	Nat/Ret	05652	05650		05648	V2	R10	A+B	>0.42	05654	05656	05658						
	Antislip/Ret	05660					R11	A+B+C	>0.42									
Grey	Nat/Ret	04988	04992		04995	V2	R10	A+B	>0.42	04999	05002	05005						
	Grip/Ret			05369			R11	A+B+C	>0.42									
Black	Nat/Ret	04989	04993		04996	V2	R10	A+B	>0.42	05000	05003	05006						

Opus

La collezione Opus è ispirata al coccio pesto, un agglomerato cementizio dell'epoca romana, un materiale antico reinterpretato dallo staff R&D di Ceramiche Piemme per creare una serie adatta a rispondere perfettamente alle esigenze dell'architettura contemporanea.

The Opus collection is inspired by Coccio Pesto, a cement agglomeration from the Roman era, an ancient material reinterpreted by Ceramiche Piemme R&D staff to create a series that perfectly meets the needs of contemporary architecture.

Die Inspiration der Opus - Serie ist „Coccio Pesto“, ein Zementagglomerat aus der Römerzeit, ein altes Material, das von den F&E-Mitarbeitern der Ceramiche Piemme neu interpretiert wurde, um eine Serie zu schaffen, die den Anforderungen der zeitgenössischen Architektur perfekt entspricht.

La collection Opus s'inspire de la terre cuite, un aggloméré de ciment de l'époque romaine, un matériau ancien réinterprété par l'équipe R&D de Ceramiche Piemme pour créer une série adaptée aux exigences de l'architecture contemporaine.

4

Colori
Colours
Farben
Couleurs

Opus Album



Opus Arena

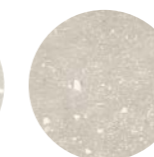

Opus Cinis

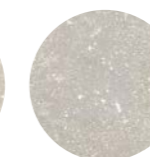

Opus Griseo

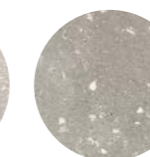

3

Formati
Sizes
Formate
Formats

120×120
48"×48"



80×80
31½"×31½"



60×60
24"×24"



1

Superfici
Surfaces
Oberflächen
Surfaces

Naturale

i

Effetto Cemento
Cement Look
Beton Optik
Effet Béton

Rivestimento
Wall Tiles
Wandfliesen
Revêtement

Pavimento
Floor Tiles
Bodenfliesen
Sol

Gres fine porcellanato ad impasto colorato
Coloured-body fine porcelain stoneware
Feinsteinzeug aus farbiger Masse
Grès cérame fin à pâte colorée

Tecnologia digitale
Digital technology
Digital technologie
Technologie numérique

▶ WATCH THE VIDEO

Album



120x120

05194A | Opus Album Nat/Ret



80x80

05190 | Opus Album Nat/Ret



60x60

05184 | Opus Album Nat/Ret

Cinis



120x120

05196A | Opus Cinis Nat/Ret



80x80

05192 | Opus Cinis Nat/Ret



60x60

05186 | Opus Cinis Nat/Ret

Arena



120x120

05195A | Opus Arena Nat/Ret



80x80

05191 | Opus Arena Nat/Ret



60x60

05185 | Opus Arena Nat/Ret

Griseo



120x120

05197A | Opus Griseo Nat/Ret



80x80

05193 | Opus Griseo Nat/Ret



60x60

05187 | Opus Griseo Nat/Ret

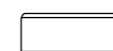
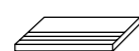
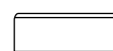



[PDF Merchandising](#)

Imballi

Packing
Verpackung
Emballage

Formati Sizes	± MM	Pezzi Scatola Pieces/Box Stck/Karton Carreaux/Boite	Mq/Scatola Sqmt/Box Qm/Karton M2/Boite	Kg/Scatola Kgs/Box Kg/Karton Kg/Boite	Scatole/Paletta Boxes/Pallet Karton/Palette Boite/Palette	Mq/Paletta Sqmt/Pallet Qm/Pallet M2/Palette	Kg/Paletta Kgs/Pallet Kg/Pallet Kg/Palette	Formato Paletta Size Pallet Format Pallet Dim. Palette	
120x120 (48"x48") Nat/Ret	P	8,5	2	2,88	55,00	24	69,12	1320	135x122x68
80x80 (31½"x31½") Nat/Ret	P	8,5	2	1,28	24,50	54	69,12	1323	124x80x96
60x60 (24"x24") Nat/Ret	P	8,5	4	1,44	26,00	40	57,60	1040	122x82x75
Pezzi Speciali / Special Pieces									
30x60 (12"x24") Step Nat/Ret	P	8,5	6	1,080	21,50	36	-	-	-
4,5x60 (1¾"x24") Battiscopa Nat/Ret	P	8,5	14	0,378	8,00	80	-	-	-

Riepilogo Gamma

Collection
Serie
Gamme

Formati Sizes										Pezzi Speciali Special Pieces	
	120x120 - 48"x48"	80x80 - 31½"x31½"	60x60 - 24"x24"	DIN 51130	DIN 51097	DCOF	BS EN 7976-2	AS 4586 2013	Step 30x60 - 12"x24"	Battiscopa 4,5x60 - 1¾"x24"	
	± 8,5	± 8,5	± 8,5						± 8,5	± 8,5	
 Opus Album Nat/Ret	05194A	05190	05184	V2	R10	A+B	>0.42	wet, dry >36	P3	05203	05198
 Opus Arena Nat/Ret	05195A	05191	05185	V2	R10	A+B	>0.42	wet, dry >36	P3	05204	05199
 Opus Cinis Nat/Ret	05196A	05192	05186	V2	R10	A+B	>0.42	wet, dry >36	P3	05205	05201
 Opus Griseo Nat/Ret	05197A	05193	05187	V2	R10	A+B	>0.42	wet, dry >36	P3	05206	05202

Suprema

La ricerca stilistica per la collezione Suprema trae ispirazione dall'estetica del cemento rasato impiegato nel design d'interni di impronta moderna. Suprema, con le sue molteplici sfumature e le leggere imperfezioni che la rendono unica, è la superficie in gres porcellanato ideale per garantire comfort e resistenza in ambienti residenziali e commerciali dallo stile sobrio ed al passo con i tempi.

The Suprema collection's distinctive style is inspired by the smoothed concrete used in modern interior design. With its unique multiple variations in shade and subtle flaws, Suprema is the ideal porcelain stoneware surface for providing convenient, hard-wearing coverings in residential and commercial locations with tasteful yet contemporary design schemes.

Der Stil der Kollektion Suprema orientiert sich an der Optik von geglättetem Beton, der das moderne Interior-Design prägt. Das Feinsteinzeug Suprema ist aufgrund seiner mannigfaltigen Nuancen und feinen Unregelmäßigkeiten die ideale Lösung für komfortable, strapazierfähige Beläge im privaten und gewerblichen Bereich, die auf schlichte, zeitgemäße Optik setzen.

Pour la collection Suprema, la recherche stylistique puise son inspiration dans l'esthétique du béton lissé appliqué dans les intérieurs modernes. Avec ses innombrables dégradés et ses légères imperfections qui en font une chose unique, Suprema est la surface en grès cérame idéale pour garantir confort et résistance dans les cadres résidentiels et commerciaux affichant un style sobre et actuel.

4

Colori
Colours
Farben
Couleurs

Gesso



Sabbia



Terra



Cenere



3

Formati
Sizes
Formate
Formats

80×80
31½"×31½"



60×60
24"×24"



30×60
12"×24"



2

Superfici
Surfaces
Oberflächen
Surfaces

Naturale

Antislip

i

Effetto Cemento
Cement look
Betonoptik
Effet Béton

Rivestimento
Wall Tiles
Wandfliesen
Revêtement

Pavimento
Floor Tiles
Bodenfliesen
Sol

Gres fine porcellanato ad impasto colorato
Coloured-body fine porcelain stoneware
Feinsteinzeug aus farbiger Masse
Grès cérame fin à pâte colorée

Tecnologia digitale
Digital technology
Digital Technologie
Technologie numérique

Gesso



80x80
05252 | Suprema Gesso Nat/Ret



60x60
03501A | Suprema Gesso Nat/Ret
*Antislip



30x60
03492A | Suprema Gesso Nat/Ret



30x30
03509 | Suprema Mosaico Gesso Nat/Ret

Terra



80x80
05254 | Suprema Terra Nat/Ret



60x60
03503A | Suprema Terra Nat/Ret
*Antislip



30x60
03494A | Suprema Terra Nat/Ret



30x30
03512 | Suprema Mosaico Terra Nat/Ret

Sabbia



80x80
05253 | Suprema Sabbia Nat/Ret



60x60
03502A | Suprema Sabbia Nat/Ret
03893A | Antislip/Ret

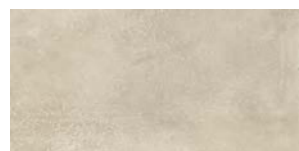

30x60
03493A | Suprema Sabbia Nat/Ret

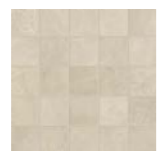

30x30
03511 | Suprema Mosaico Sabbia Nat/Ret

Cenere



80x80
05255 | Suprema Cenere Nat/Ret



60x60
03504A | Suprema Cenere Nat/Ret
*Antislip

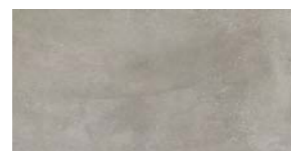

30x60
03495A | Suprema Cenere Nat/Ret



30x30
03513 | Suprema Mosaico Cenere Nat/Ret

Imballi

Packing
Verpackung
Emballage

Formati Sizes		± MM	Pezzi Scatola Pieces/Box Stck/Karton Carreaux/Boîte	Mq/Scatola Sqmt/Box Qm/Karton M2/Boîte	Kg/Scatola Kgs/Box Kg/Karton Kg/Boîte	Scatole/Paletta Boxes/Pallet Karton/Palette Boîte/Palette	Mq/Paletta Sqmt/Pallet Qm/Pallet M2/Palette	Kg/Paletta Kgs/Pallet Kg/Pallet Kg/Palette	Formato Paletta Size Pallet Format Pallet Dim. Palette
80x80 (31½"x31½") Nat/Ret	P	8,5	2	1,28	24,50	54	69,12	1323	124x80x96
60x60 (24"x24") Nat/Ret - Antislip/Ret	P	8,5	4	1,44	26,00	40	57,60	1040	122x82x75
30x60 (12"x24") Nat/Ret	P	8,5	7	1,26	22,50	48	60,48	1080	120x80x75
30x30 (12"x12") Mosaico Nat/Ret	P	8,5	5	0,45	8,50	60	-	-	-
Pezzi Speciali / Special Pieces									
4,5x60 (1¼"x24") Battiscopa Nat/Ret	P	8,5	14	0,378	8,00	80	-	-	-

Riepilogo Gamma

Collection
Serie
Gamme

Formati Sizes		80x80 31½"x31½"	60x60 24"x24"	30x60 12"x24"			Mosaico 30x30 - 12"x12"	Battiscopa 4,5x60 - 1¼"x24"
		± 8,5	± 8,5	± 8,5	Din 51130	Din 51197		
Gesso	Nat/Ret	05252	03501A	03492A	V2	R9	03509	03518
	*Antislip/Ret							
Sabbia	Nat/Ret	05253	03502A	03493A	V2	R9	03511	03519
	Antislip/Ret		03893A			R11	A+B+C	
Terra	Nat/Ret	05254	03503A	03494A	V2	R9	03512	03521
	*Antislip/Ret							
Cenere	Nat/Ret	05255	03504A	03495A	V2	R9	03513	03522
	*Antislip/Ret							

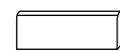

Concrete

Lo studio di design per la collezione Concrete trae ispirazione dalla lavorazione del cemento rasato per superfici industriali. Concrete è una superficie dal mood minimale ed allo stesso tempo profondo e ricercato.

The design study for the Concrete collection takes its inspiration from the working of smoothed concrete for industrial surfaces. Concrete is a surface with a minimal and at the same time deep and elegant mood.

Die Designstudie für die Kollektion Concrete ist an der Optik glattgeputzten Betons für Industrieflächen inspiriert. Concrete erzeugt eine minimalistisch und zugleich intensiv und edel wirkende Oberfläche.

Pour la collection Concrete, le design s'inspire du béton ciré utilisé pour la réalisation des surfaces industrielles. Concrete est une surface à l'aspect à la fois essentiel, profond et raffiné.

5

Colori
Colours
Farben
Couleurs

White



Taupe



Warm Grey



Light Grey



Black

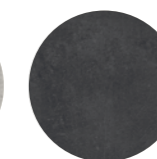

8

Formati
Sizes
Formate
Formats

120×120

48"×48"



60×120

24"×48"



80×80

31½"×31½"



60,4×60,4
60×60

24"×24"



30,1×60,4
30×60

12"×24"



45,4×45,4

18"×18"



3

Superfici
Surfaces
Oberflächen
Surfaces

Naturale

Antislip

Grip

i

Effetto Cemento
Cement look
Betonoptik
Effet Béton

Rivestimento
Wall Tiles
Wandfliesen
Revêtement

Pavimento
Floor Tiles
Bodenfliesen
Sol

Gres fine porcellanato ad impasto colorato
Coloured-body fine porcelain stoneware
Feinsteinzeug aus farbiger Masse
Grès cérame fin à pâte colorée

Tecnologia digitale
Digital technology
Digital Technologie
Technologie numérique

White



120×120

05298 | Concrete White Nat/Ret



80×80

03669A | Concrete White Nat/Ret

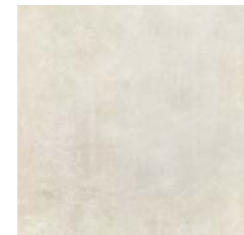

60,4×60,4

03742A | Concrete White Nat

60×60

00934A | Concrete White Nat/Ret



45,4×45,4

03797A | Concrete White Nat



60×120

05305 | Concrete White Nat/Ret



30,1×60,4

03754A | Concrete White Nat

03759A | Concrete White Antislip Nat

30×60

00928A | Concrete White Nat/Ret



30×30

00983 | Concrete Mosaico
White Nat/Ret

Taupe



120×120

05349 | Concrete Taupe Nat/Ret



80×80

03671A | Concrete Taupe Nat/Ret

03835A | Concrete Taupe Antislip Ret



60,4×60,4

03743A | Concrete Taupe Nat

60×60

00935A | Concrete Taupe Nat/Ret

02973B | Concrete Taupe Grip/Ret
± 20mm



45,4×45,4

03798A | Concrete Taupe Nat



60×120

05306 | Concrete Taupe Nat/Ret

05583 | Concrete Taupe Grip/Ret ± 20mm



30,1×60,4

03755A | Concrete Taupe Nat

03761A | Concrete Taupe Antislip Nat

30×60

00929A | Concrete Taupe Nat/Ret



30×30

00984 | Concrete Mosaico
Taupe Nat/Ret

Warm Grey



120×120

05352 | Concrete Warm Grey Nat/Ret



80×80

03673A | Concrete Warm Grey Nat/Ret

03837A | Concrete Warm Grey Antislip Ret



60,4×60,4

03745A | Concrete Warm Grey Nat

60×60

00937A | Concrete Warm Grey Nat/Ret

02975B | Concrete Warm Grey Grip/Ret
± 20mm



45,4×45,4

03800A | Concrete Warm Grey Nat



60×120

05308 | Concrete Warm Grey Nat/Ret

05584 | Concrete Warm Grey Grip/Ret ± 20mm



30,1×60,4

03757A | Concrete Warm Grey Nat

03763A | Concrete Warm Grey Antislip Nat

30×60

00932A | Concrete Warm Grey Nat/Ret



30×30

00986 | Concrete Mosaico
Warm Grey Nat/Ret

Light Grey



120×120

05351 | Concrete Light Grey Nat/Ret



80×80

03672A | Concrete Light Grey Nat/Ret

03836A | Concrete Light Grey Antislip Ret



60,4×60,4

03744A | Concrete Light Grey Nat

60×60

00936A | Concrete Light Grey Nat/Ret

02974B | Concrete Light Grey Grip/Ret
± 20mm



45,4×45,4

03799A | Concrete Light Grey Nat



60×120

05307 | Concrete Light Grey Nat/Ret

05585 | Concrete Light Grey Grip/Ret ± 20mm



30,1×60,4

03756A | Concrete Light Grey Nat

03762A | Concrete Light Grey Antislip Nat

30×60

00931A | Concrete Light Grey Nat/Ret



30×30

00985 | Concrete Mosaico
Light Grey Nat/Ret



Step 30×60

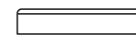

Battiscopa 8×45
Battiscopa 8×60
Battiscopa 8×80

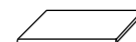

Gradone 30×60 ± 20



Griglia Scolo 18×60 ± 20



INDEX



Step 30×60

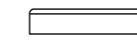

Battiscopa 8×45
Battiscopa 8×60
Battiscopa 8×80

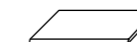

Gradone 30×60 ± 20



Griglia Scolo 18×60 ± 20



INDEX

Black



80x80
03674A | Concrete Black Nat/Ret



60,4x60,4
03746A | Concrete Black Nat
60x60
00938A | Concrete Black Nat/Ret



45,4x45,4
03801A | Concrete Black Nat



30,1x60,4
03758A | Concrete Black Nat
03764A | Concrete Black Antislip Nat
30x60
00933A | Concrete Black Nat/Ret

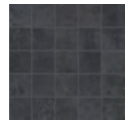

30x30
00987 | Concrete Mosaico Black Nat/Ret

Concrete

Imballi

Packing
Verpackung
Emballage

Formato / Size		± MM	Pezzi/Scatola Pieces/Box Stck/Karton Carreaux/Boîte	Mq/Scatola Sqmt/Box Qm/Karton M2/Boîte	Kg/Scatola Kgs/Box Kg/Karton Kg/Boîte	Scatole/Paletta Boxes/Pallet Karton/Pallet Boîte/Palette	Mq/Paletta Sqmt/Pallet Qm/Pallet M2 /Palette	Kg/Paletta Kgs/Pallet Kg/Pallet Kg/Palette	Formato Paletta Size Pallet Format Pallet Dim. Palette
120x120 Nat/Ret	P	8,5	2	2,88	55	24	69,12	1320	135x122x68
80x80 Nat/Ret - Antislip/Ret	P	8,5	2	1,28	24,50	54	69,12	1323	124x80x96
60x120 Nat/Ret	P	8,5	2	1,44	28,00	36	51,84	1008	122x82x75
60x120 Grip/Ret	P	20	1	0,72	33,00	36	25,92	1188	122x96x75
60,4x60,4 Nat	P	8,5	4	1,46	26,50	40	58,40	1060	122x82x75
60x60 Nat/Ret	P	8,5	4	1,44	26	40	57,60	1040	122x82x75
60x60 Grip/Ret	P	20	2	0,72	32	32	23,04	1024	120x80x75
45,4x45,4 Nat	P	8,0	6	1,240	21,00	66	81,84	1386	120x80x105
30,1x60,4 Nat - Antislip	P	8,5	7	1,273	23,00	48	61,10	1104	120x80x75
30x60 Nat/Ret	P	8,5	7	1,26	22,50	48	60,48	1080	120x80x75
30x30 Mosaico (Su Rete)	P	8,5	5	0,45	8,5	60			
Pezzi Speciali / Special Pieces									
8x80 Battiscopa	P	8,5	7	0,448	11	65			
8x60 Battiscopa	P	8,5	10	0,48	11	72			
8x45 Battiscopa	P	8,5	30	1,08	23,3	30			
30x60 Step	P	8,5	6	1,08	22	36			
30x60 Gradone	P	20	2	0,36	17	36			
30x60 Elemento L	P	20	2	0,36	17	30			
18x60 Griglia Scolo	P	20	1	0,108	5	48			



Step 30x60

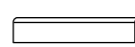

Battiscopa 8x45
Battiscopa 8x60
Battiscopa 8x80

Formati Sizes											UPEC			
	120x120 48"x48"	80x80 31½"x31½"	60x120 24"x48"	60x120 24"x48"	60,4x60,4 24"x24"	60x60 24"x24"	60x60 24"x24"	30,1x60,4 12"x24"	30x60 12"x24"	45,4x45,4 18"x18"	DIN 51130	DIN 51097	DCOF	
White	Nat				03742A			03754A		03797A	V2	R10	A	> 0,42
	Nat/Ret	05298	03669A	05305			00934A		00928A			R11	A+B+C	> 0,42
	Antislip Nat							03759A						
Taupe	Nat				03743A			03755A		03798A	V2	R10	A	> 0,42
	Nat/Ret	05349	03671A	05306			00935A		00929A			R11	A+B+C	> 0,42
	Antislip Nat							03761A						
	Antislip Ret		03835A											
	Grip/Ret				05583			02973B				R11	A+B+C	
Warm Grey	Nat				03745A			03757A		03800A	V2	R10	A	> 0,42
	Nat/Ret	05352	03673A	05308			00937A		00932A			R11	A+B+C	> 0,42
	Antislip Nat							03763A						
	Antislip Ret		03837A											
	Grip/Ret				05584			02975B				R11	A+B+C	
Light Grey	Nat				03744A			03756A		03799A	V2	R10	A	> 0,42
	Nat/Ret	05351	03672A	05307			00936A		00931A			R11	A+B+C	> 0,42
	Antislip Nat							03762A						
	Antislip Ret		03836A											
	Grip/Ret				05585			02974B				R11	A+B+C	
Black	Nat				03746A			03758A		03801A	V2	R10	A	> 0,42
	Nat/Ret		03674A				00938A		00933A			R11	A+B+C	> 0,42
	Antislip Nat							03764A						

CLICK

PDF Merchandising

Formati Sizes	Mosaico 30x30 Su Rete 12"x12" (2"x2" Dot)	
	8,5	
White	Nat	00983
	Nat/Ret	00984
Taupe	Nat	00986
	Nat/Ret	00985
Warm Grey	Nat	00987
	Nat/Ret	00988
Light Grey	Nat	00989
	Nat/Ret	00990
Black	Nat	00991
	Nat/Ret	00992

Pezzi Speciali Special Pieces						
Battiscopa 8x80 3¼"x31½"	Battiscopa 8x60 3¼"x24"	Battiscopa 8x45 3¼"x18"	Step 30x60 12"x24"	Gradone 30x60 12"x24"	Elemento L 30x60 12"x24"	Griglia Scolo 18x60 7¼"x24"
8,5	8,5	8,5	8,5	20	20	20
01529	00994		01005			
	00989	01001	01007			
01530	00995			03205	03208	03212
	00992	01003	01009			
01532	00997			03207	03211	03214
	00991	01002	01008			
01531	00996			03206	03209	03213
	00993	01004	01011			
01533	00998					

Pezzi Speciali su Richiesta - Special pieces upon request
Formstücke auf Anfrage - Pièces spéciales sur demande

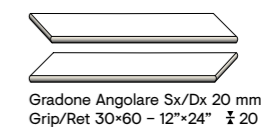

Gradone Angolare Sx/Dx 20 mm
Grip/Ret 30x60 - 12x24 8,5

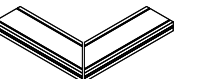

Griglia Scolo Angolare Sx/Dx 20 mm
Grip/Ret 18x60 - 7¼x24 8,5

Venetian Marble

Una collezione ispirata al terrazzo alla veneziana; utilizzato fin dall'antichità in Grecia ha poi raggiunto l'Italia con larga diffusione grazie agli antichi romani prima ed ai nobili veneziani poi.

A collection inspired by the Venetian terrazzo flooring used since ancient times in Greece. It then reached and became widespread in Italy, first of all thanks to the ancient Romans and then to the Venetian nobles.

Die Kollektion ist am venezianischen Terrazzoboden inspiriert, der bereits in der griechischen Antike bekannt war und dann in Italien weite Verbreitung fand - im alten Rom wie später in den Adelshäusern Venedigs.

Une collection inspirée du terrazzo à la vénitienne. Apprécié depuis l'Antiquité en Grèce, le terrazzo a été largement diffusé en Italie par les anciens Romains d'abord et par la noblesse vénitienne ensuite.

4

Colori
Colours
Farben
Couleurs

Rainbow

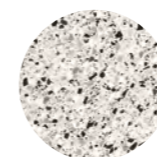

Cloud

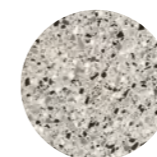

Fog

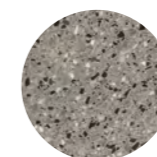

Storm

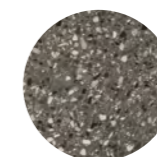

3

Formati
Sizes
Formate
Formats

60×120
24"×48"



60×60
24"×24"



30×60
12"×24"



1

Superfici
Surfaces
Oberflächen
Surfaces

Naturale

i

Effetto Contemporaneo
Contemporary effect
Moderne Wirkung
Effet Contemporain

Rivestimento
Wall Tiles
Wandfliesen
Revêtement

Pavimento
Floor Tiles
Bodenfliesen
Sol

Gres fine porcellanato ad impasto colorato
Coloured-body fine porcelain stoneware
Feinsteinzeug aus farbiger Masse
Grès cérame fin à pâte colorée

Tecnologia digitale
Digital technology
Digital Technologie
Technologie numérique

Venetian Marble

Gres fine porcellanato ad impasto colorato / Tecnologia digitale
Coloured-body fine porcelain stoneware / Digital technology

Feinsteinzeug aus farbiger Masse / Digital Technologie
Grès cérame fin à pâte colorée / Technologie numérique

Contemporary
CONTRACT

Rainbow



60x120

02657A | Venetian Marble Rainbow Nat/Ret

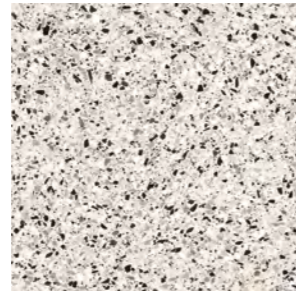

60x60

02688A | Venetian Marble Rainbow Nat/Ret

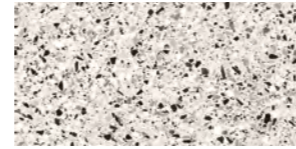

30x60

03063A | Venetian Marble Rainbow Nat/Ret

Cloud



60x120

02692A | Venetian Marble Cloud Nat/Ret

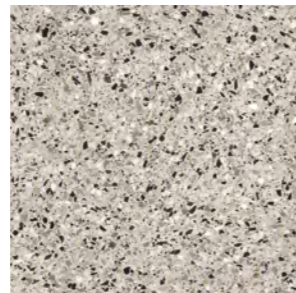

60x60

02689A | Venetian Marble Cloud Nat/Ret

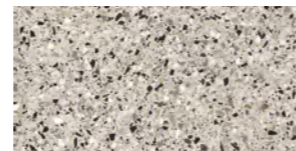

30x60

03066A | Venetian Marble Cloud Nat/Ret

Fog



60x120

02693A | Venetian Marble Fog Nat/Ret

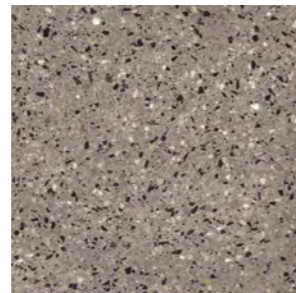

60x60

02690A | Venetian Marble Fog Nat/Ret

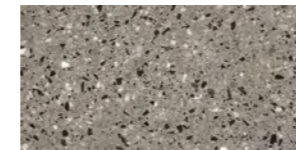

30x60

03067A | Venetian Marble Fog Nat/Ret

Storm



60x120

02694A | Venetian Marble Storm Nat/Ret

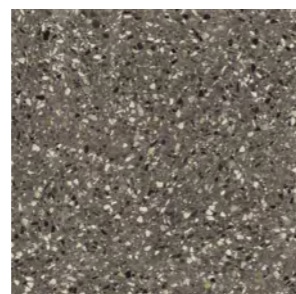

60x60

02691A | Venetian Marble Storm Nat/Ret

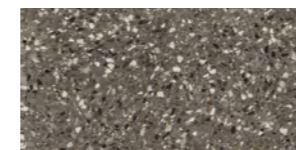

30x60

03068A | Venetian Marble Storm Nat/Ret

Venetian Marble

Imballi

Packing
Verpackung
Emballage

Formati Sizes		± MM	Pezzi Scatola Pieces/Box Stck/Karton Carreaux/Boîte	Mq/Scatola Sqmt/Box Qm/Karton M2/Boîte	Kg/Scatola Kgs/Box Kg/Karton Kg/Boîte	Scatole/Paletta Boxes/Pallet Karton/Palette Boîte/Palette	Mq/Paletta Sqmt/Pallet Qm/Pallet M2/Palette	Kg/Paletta Kgs/Pallet Kg/Pallet Kg/Palette	Formato Paletta Size Pallet Format Pallet Dim. Palette
60x120 (24"x48") Nat/Ret	P	8,5	2	1,44	28,00	36	51,84	1008	122x82x75
60x60 (24"x24") Nat/Ret	P	8,5	4	1,44	26,00	40	57,60	1040	122x82x75
30x60 (12"x24") Nat/Ret	P	8,5	7	1,26	22,50	48	60,48	1080	120x80x75
Pezzi Speciali / Special Pieces									
30x60 (12"x24") Step Nat/Ret	P	8,5	6	1,080	21,50	36	-	-	-
8x60 (3 1/2"x24") Battiscopa Nat/Ret	P	8,5	10	0,480	11,00	72	-	-	-

Riepilogo Gamma

Collection
Serie
Gamme

	Formati Sizes				Pezzi Speciali Special Pieces		
					Step 30x60 - 12"x24"	Battiscopa 8x60 - 3 1/2"x24"	
Rainbow	Nat/Ret	02657A	02688A	03063A	V3	02812	02695
Cloud	Nat/Ret	02692A	02689A	03066A	V3	02813	02696
Fog	Nat/Ret	02693A	02690A	03067A	V3	02814	02697
Storm	Nat/Ret	02694A	02691A	03068A	V3	02815	02698

TECHNICAL DATA

Dati Tecnici / Technische Daten / Fiches Techniques

CLICK



358 PEZZI SPECIALI

Special pieces / Formstücke /
Pièces spéciales

363 GUIDA ALLA LETTURA

Reading Guide / Leseanleitung /
Guide a la lecture

364 NOTE TECNICHE 120x120 / 120x280

120x120 - 120x280 Technical Notes / Technische Hinweise 120x120 - 120x280 /
Notes Techniques 120x120 - 120x280

366 NORME DI POSA

Installation instructions / Hinweise Für Die Verlegung /
Pose

368 NORME DI MANUTENZIONE

Cleaning / Hinweise Zur Pflege /
Règles D'entretien

370 GRES FINE PORCELLANATO

Porcelain Stoneware / Feinsteinzeug /
Grès Cérame

371 PASTA BIANCA

White Body / Weißscherbig /
Pâte Blanche

372 CERTIFICAZIONI

Certifications / Zertifizierungen /
Certifications

376 CONDIZIONI DI VENDITA

General Terms and Conditions of Sale / Allgemeine Verkaufsbedingungen /
Conditions Generales de Vente

Pezzi Speciali

Special pieces
Formstücke
Pièces spéciales

Battiscopa

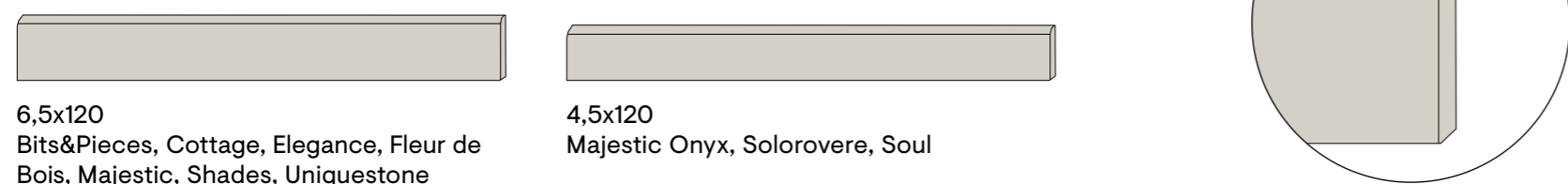
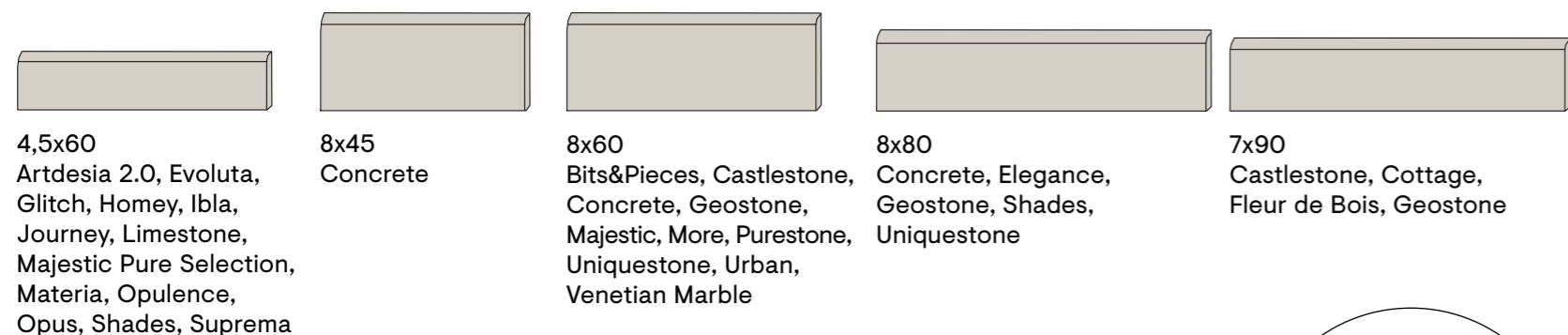

Bacchetta Jolly

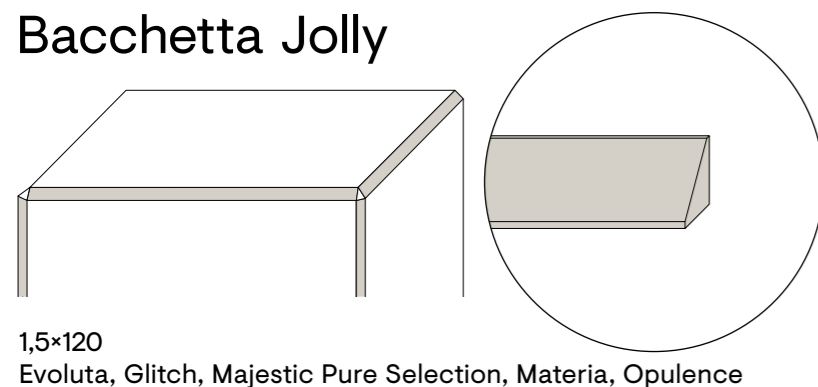

Unghia Jolly

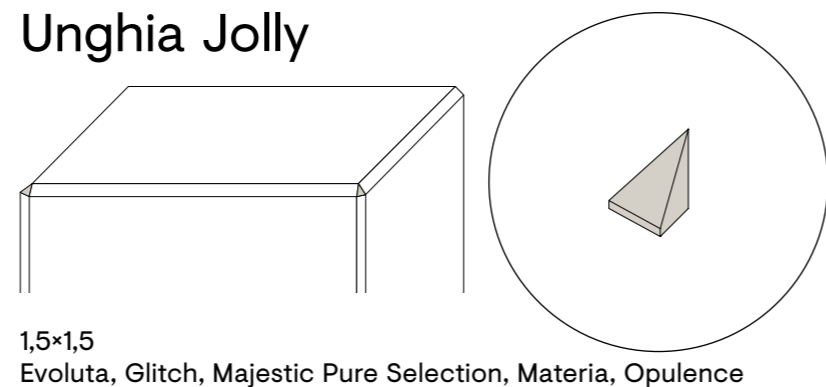

Step

(becco civetta e fresature tecniche - bullnose edge with grooves)

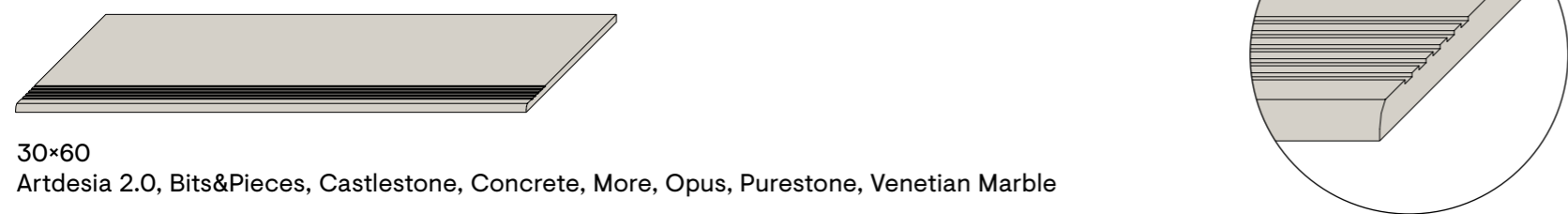

Step

(becco civetta tecnico - bullnose edge)

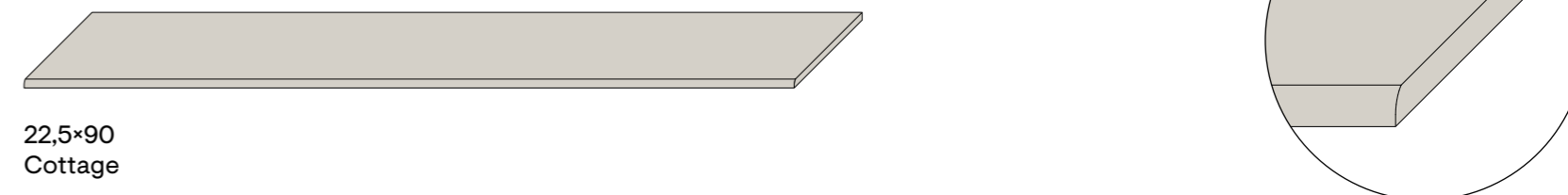

Step

(becco civetta digitale a caldo - hot digital bullnose edge)

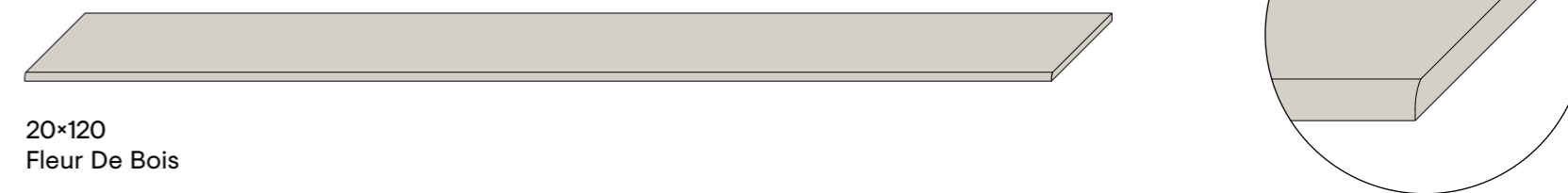

Step

(becco civetta tecnico - bullnose edge)

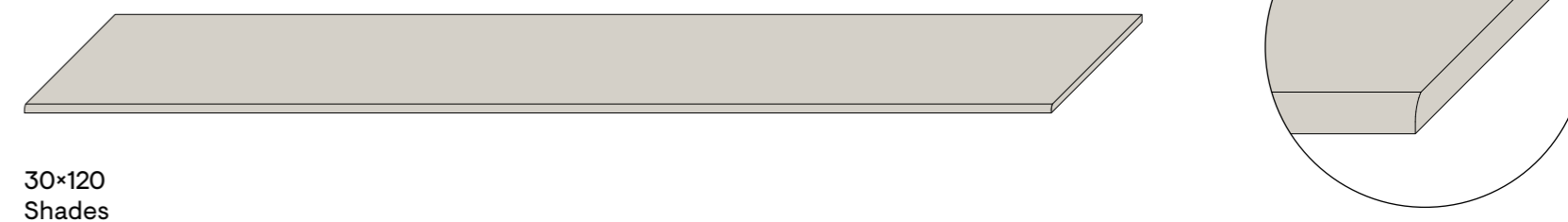

Gradino Costa Retta

(ottenuto per taglio e incollaggio - obtained by cutting and gluing)

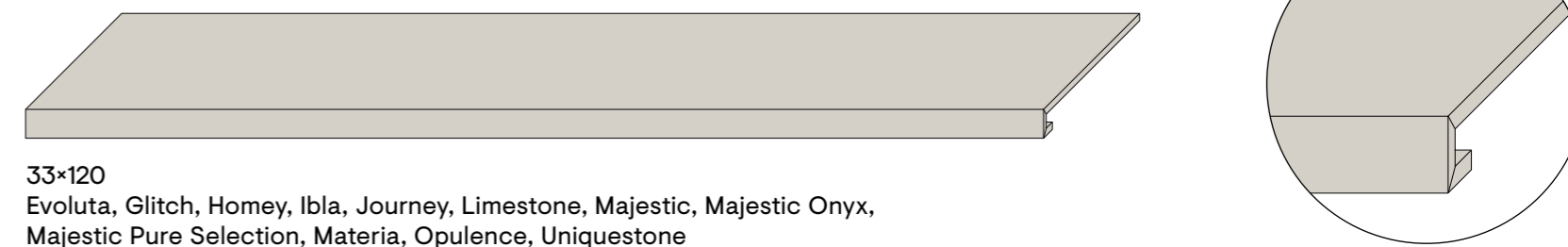

Pezzi Speciali 20mm

20mm special pieces
Formstücke 20mm
Pièces spéciales 20mm

Elemento L

(ottenuto per taglio e incollaggio - obtained by cutting and gluing)



30x60x5 Sp.20mm Concrete, Urban
30x90x5 Sp.20mm Materia

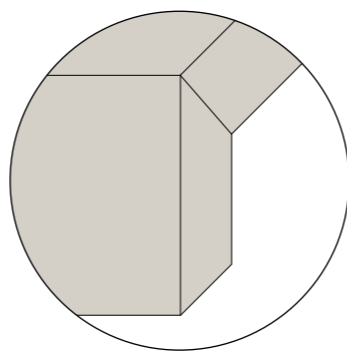

Gradone

(Toro tecnico - full bullnose edge)

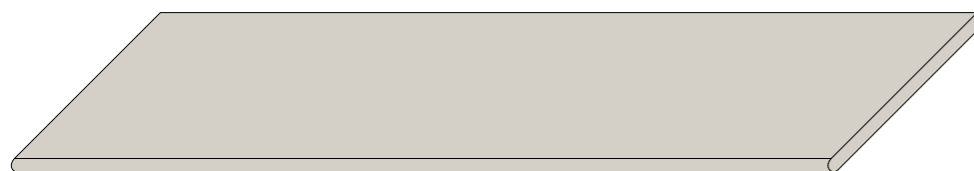

30x60 Sp.20mm Concrete, Urban
33x90 Sp.20mm Materia

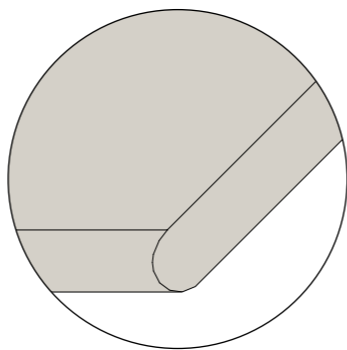

Griglia Scolo

(ottenuto per taglio e incollaggio - obtained by cutting and gluing)



18x60 Sp.20mm Concrete, Urban
18x90 Sp.20mm Materia

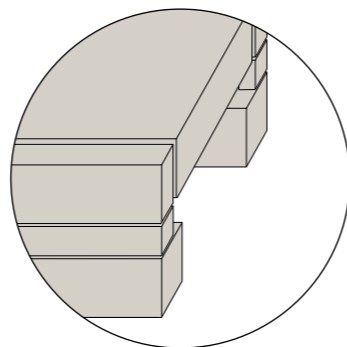

Pezzi Speciali 20mm su Richiesta

20mm special pieces upon request
Formstücke 20mm auf Anfrage
Pièces spéciales 20mm sur demande

Gradone Angolare

(toro tecnico - full bullnose edge)

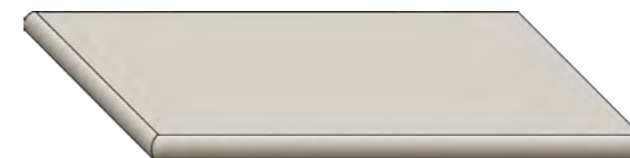

Angolo Sx

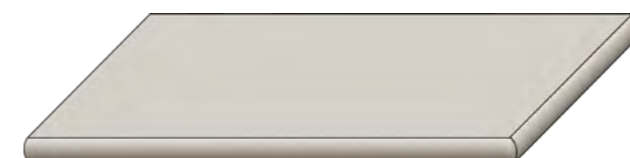

Angolo Dx

30x60 Sp.20mm Concrete, Urban
33x90 Sp.20mm Materia

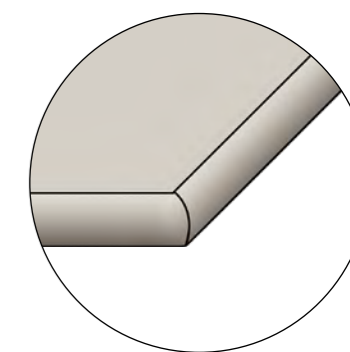

Griglia Scolo Angolare

(ottenuto per taglio e incollaggio - obtained by cutting and gluing)

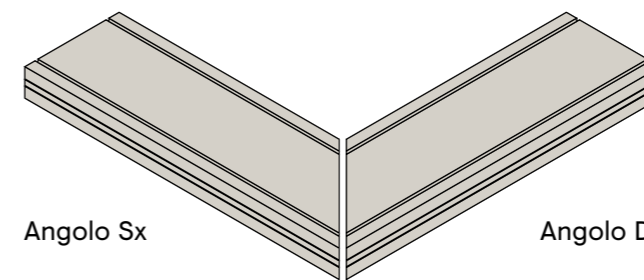

Angolo Sx

Angolo Dx

18x60 Sp.20mm Concrete, Urban

18x90 Sp.20mm Materia

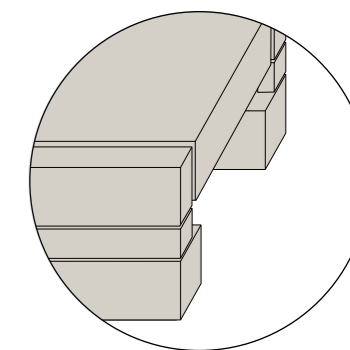

Guida alla Lettura

Reading Guide
Leseanleitung
Guide à la lecture

 Spessore
Thickness
Stärke
Épaisseur

Variazione nelle sfumature di colore
Color shade variations
Variation der Farbnuancen
Variation des nuances de couleur

Certificazioni
Certifications
Prüfzeugnisse
Certifications

P Gres fine porcellanato
Porcelain Stoneware
Feinsteinzeug
Grès Cérame

 V1 Aspetto uniforme
Uniform appearance
Gleichförmiges aussehen
Aspect uniforme



PB Pasta Bianca
White Body
Weißscherbisig
Pâte Blanche

 V2 Variazione leggera
Slight variation
Leichte variation
Légère variation



 V3 Variazione moderata
Moderate variation
Mäßige variation
Variation modeste

Resistenza alla scivolosità
Skid resistance
Rutschfestigkeit
Resistance au glissement

 V4 Variazione casuale
Random variation
Zufällige variation
Variation fortuite

DIN 51130	DIN 51097	DCOF
R11	A+B+C	>0,42

Tutti i formati sono nominali.
Gli spessori riportati in questo catalogo sono nominali e possono variare a seconda dei formati e delle finiture.
I colori e le caratteristiche estetiche dei prodotti sono quanto più possibile vicini a quelli reali, nei limiti consentiti dai processi di stampa.

All sizes are nominal.
The thickness mentioned on this catalogue are nominal and can be different according to the sizes and the finishes.
The colours and appearance features of the products are as close as possible to reality, within the limitation of the printing process.

Die Formate sind Nennwerte.
Die in diesem Katalog angegebenen Fliesenstärke sind nominal und können, je nach Format oder Oberfläche, verschieden sein.
Die Farben und die ästhetischen Eigenschaften der Produkte entsprechen der Wirklichkeit, innerhalb den von dem Druckverfahren erlaubten Grenzen.

Tous les formats sont nominaux.
Les épaisseurs reportées sur ce catalogue sont nominales et peuvent varier suivant les formats et les finitions.
Les couleurs et les caractéristiques esthétiques sont fidèles aux couleurs et caractéristique réelles dans les limites des procédés d'impression.

Все форматы являются номинальными.
Указанная в данном каталоге толщина является номинальной и может изменяться в зависимости от форматов и отделки.
Цвета и эстетические характеристики изделий максимально приближены к реальным, в рамках возможностей типографских процессов.

<p>قواعد التركيب</p>
<p>بالنسبة للمنتجات المصححة، نوصي بترك مسافة 2 مم للحصول على نتائج تركيب أفضل.</p>
<p>للحصول على ناتج جمالي أفضل، نوصي شركة بييمي "Piemme" بالجنص الملون مع البلاط.</p>
<p>تحقق قبل الاستخدام من توافق وملاءمة مواد ملء المسافات مع منتج السيراميك.</p>
<p>قم بإزالة زيادات مادة حشو المسافات قبل أن تجف.</p>

اتبع بدقة التعليمات المقدمة من قبل الشركة المصنعة لمواد حشو المسافات.

للتخلص التام من بقايا التركيب، والتي يمكن أن تؤثر على الصيانة العادية وخصائص المنتج، بعد انتهاء التركيب، ابدأ في التنظيف باستخدام منتجات مناسبة، مكونة من أحماض بحد أقصى 3٪، مع مراعاة إرشادات الشركة المصنعة. امتثل تمامًا للحدود الزمنية الموضحة في التعليمات: قد يؤدي التلامس لمدة طويلة مع هذه المنتجات إلى إتلاف السطح.

يمكن إزالة أي هالات يمكن أن تحدث بعد تركيب المواد المطلية أو المصقولة بسهولة باستخدام منتج مناسب مكون من مواد قلوية.

فيما يتعلق باستخدام مواد السيراميك في الخارج، مع التأكيد أيضًا من عدم تأثير منتجات بييمي "Piemme" المصنوعة من الخزف الحجري بالصفيق، وفقًا للمعايير الأوروبية السارية، إستثناءً من إجراءات الصيانة، لا يلزم اتباع بعض القواعد الأساسية للتركيب بالإسكان الخارجية، مناسبة لجعل الأرضيات المذكورة أعلاه مقاومة للصدئ. أهم الشروط الواجب الامتثال لها هي: نسب الميول المناسبة، مقاومة الماء، وصلات التمدد، واستخدام المواد المناسبة للتركيب.

*الخزاف المصنوعة من المينا والمعادن الثمينة: من الضروري حماية السطح أثناء التركيب، وعدم استخدام المنتجات الكاشطة والأحماض أو أيهما، ولكن فقط الماء والصابون المحايد. الشركة المصنعة ليست مسؤولة عن أي أضرار التي تلحق بهذه المواد الثمينة وتنتج عن "الإحتكاك" أثناء التركيب. لن يتم قبول المنازعات المتعلقة بالمواد المركبة لأي سبب من الأسباب.

ملاحظة:

PRIMÉCIATION:
كما هو محدد في معيار الاتحاد الأوروبي UNI 11493.2013، пункт 5.2.2: "يجب إجراء الفحص البصري لسطح البلاط من مسافة لا تقل عن 1.5 متر بطول رجل. لا يُسمح بإضاءة ضوء متلاصق. الآثار السطحية التي لا يمكن اكتشافها في هذه الظروف لا تعد عيوبًا".

لا تتحمل شركة بييمي "Piemme" أي مسؤولية إذا لم يتم الالتزام بقواعد التركيب والتنظيف والصيانة المذكورة أعلاه.

لمزيد من المعلومات المحددة ، يرجى الرجوع إلى المنطقة الفنية على موقع بييمي "Piemme":

www.ceramichepiemme.it

<p>قواعد التركيب</p>
<p>بالنسبة للمنتجات المصححة، نوصي بترك مسافة 2 مم للحصول على نتائج تركيب أفضل.</p>
<p>للحصول على ناتج جمالي أفضل، نوصي شركة بييمي "Piemme" بالجنص الملون مع البلاط.</p>
<p>تحقق قبل الاستخدام من توافق وملاءمة مواد ملء المسافات مع منتج السيراميك.</p>
<p>قم بإزالة زيادات مادة حشو المسافات قبل أن تجف.</p>

Для калиброванной (обрезной) плитки мы советуем предусмотреть шов в 2 мм для получения наилучшего результата укладки. Для наиболее удачного эстетического эффекта Piemme рекомендует использовать цветные затирки, сочетающиеся с цветом плитки. Перед началом затирки проверьте пригодность заполнителей швов и их совместимость с керамическим изделием. Удалите излишки заполнителя швов, пока они еще свежие. Тщательно соблюдайте инструкции, предоставленные производителями заполнителей швов. Для полного удаления остатков укладочных материалов, которые могут ухудшить результаты обычной чистки и характеристики продукции, по завершению укладки выполните чистку с использованием специальных средств на кислотной основе (макс. 3%), придерживаясь указаний производителя. Обязательно соблюдайте указанное в инструкциях предельное время выдержки: слишком продолжительное воздействие этих средств может повредить поверхность. Если после укладки притертого или полированного материала обнаруживаются налеты, то их можно легко удалить с применением подходящего средства на щелочной основе. Касательно использования керамической продукции для наружных работ, мы подтверждаем, что керамогранитная продукция Piemme является морозостойкой в соответствии с действующими европейскими стандартами EN 14411/ISO 13006-ISO 10545.12, тем не менее, необходимо соблюдать основные правила по укладке вне помещений, исключающие воздействие мороза на полах. Наиболее важную роль играют следующие условия: создание необходимого уклона пола, обеспечение гидроизоляции, устройство расширительных швов, применение соответствующих укладочных материалов.*Декоры, выполненные с использованием глазури и драгоценных металлов:Необходимо обязательно защищать их поверхность во время укладки. Для их чистки ни в коем случае не использовать абразивные и/или кислотные средства, следует пользоваться только водой и нейтральным моющим средством. Производитель не несет ответственности за ущерб, вызванный царапинами на этой ценной продукции, нанесенными во время укладки. Претензии по уложенному материалу к рассмотрению не принимаются ни на каком основании.

PRIMÉCIATION:
كما هو محدد في معيار الاتحاد الأوروبي UNI 11493.2013، пункт 5.2.2: "осмотр облицованной плиткой поверхности необходимо выполнять на минимальном расстоянии 1,5 м, на высоте человеческого роста. Применение скользящего освещения при осмотре не допускается. Эффекты на поверхности, не обнаруживаемые в вышеуказанных условиях, дефектами не считаются."

Piemme sncиаает с себя любую ответственность в случае несоблюдения вышеприведенных правил по укладке, чистке и уходу.

Для получения дополнительной информации посетите раздел сайта Piemme: www.ceramichepiemme.it

<p>Правила Укладки</p>
<p>Для калиброванной (обрезной) плитки мы советуем предусмотреть шов в 2 мм для получения наилучшего результата укладки. Для наиболее удачного эстетического эффекта Piemme рекомендует использовать цветные затирки, сочетающиеся с цветом плитки. Перед началом затирки проверьте пригодность заполнителей швов и их совместимость с керамическим изделием. Удалите излишки заполнителя швов, пока они еще свежие. Тщательно соблюдайте инструкции, предоставленные производителями заполнителей швов. Для полного удаления остатков укладочных материалов, которые могут ухудшить результаты обычной чистки и характеристики продукции, по завершению укладки выполните чистку с использованием специальных средств на кислотной основе (макс. 3%), придерживаясь указаний производителя. Обязательно соблюдайте указанное в инструкциях предельное время выдержки: слишком продолжительное воздействие этих средств может повредить поверхность. Если после укладки притертого или полированного материала обнаруживаются налеты, то их можно легко удалить с применением подходящего средства на щелочной основе. Касательно использования керамической продукции для наружных работ, мы подтверждаем, что керамогранитная продукция Piemme является морозостойкой в соответствии с действующими европейскими стандартами EN 14411/ISO 13006-ISO 10545.12, тем не менее, необходимо соблюдать основные правила по укладке вне помещений, исключающие воздействие мороза на полах. Наиболее важную роль играют следующие условия: создание необходимого уклона пола, обеспечение гидроизоляции, устройство расширительных швов, применение соответствующих укладочных материалов.*Декоры, выполненные с использованием глазури и драгоценных металлов:Необходимо обязательно защищать их поверхность во время укладки. Для их чистки ни в коем случае не использовать абразивные и/или кислотные средства, следует пользоваться только водой и нейтральным моющим средством. Производитель не несет ответственности за ущерб, вызванный царапинами на этой ценной продукции, нанесенными во время укладки. Претензии по уложенному материалу к рассмотрению не принимаются ни на каком основании.</p>
<p>Для получения дополнительной информации посетите раздел сайта Piemme: www.ceramichepiemme.it</p>

Pour les produits rectifiés, il est conseillé de confectionner un joint de 2mm pour parfaire le résultat de la pose.

Pour améliorer le rendu esthétique, Piemme conseille des joints colorés assortis aux carreaux.

Avant d'utiliser les produits de jointement, vérifier s'ils sont compatibles avec la céramique.

Enlever l'excédent de produit de jointement tant qu'il est encore frais.

Respecter scrupuleusement les règles imparties par les fabricants de produits de jointement.

Pour éliminer complètement les résidus de pose qui pourraient compromettre l'entretien courant et les caractéristiques du produit à la fin de la pose, utiliser des produits appropriés à base acide max. 3% en respectant les consignes du fabricant. Suivre scrupuleusement les délais figurant dans les notices car un contact trop long de ces produits sur le carrelage pourrait l'endommager.

Il peut se faire que des halos subsistent après la pose de matériaux adoucis ou polis. Pour les éliminer, utiliser des produits appropriés à base alcaline.

En ce qui concerne les matériaux céramiques posés à l'extérieur, Piemme rappelle que ses produits en grès cérame sont ingélifs, conformément aux normes européennes en vigueur EN 14411/ISO 13006-ISO 10545.12. Respecter les règles de pose à l'extérieur pour que le gel reste inoffensif. Les points les plus importants à respecter sont les suivants : bonne inclinaison, imperméabilisation, joints de dilatation et utilisation de produits de pose spécifiques.

*Décors réalisés avec des émaux et des métaux précieux:

Il est indispensable de protéger la surface pendant la pose. N'utiliser en aucun cas un produit abrasif et/ou acide mais uniquement de l'eau et du savon neutre. Le fabricant ne peut être tenu pour responsable des dommages causés à ces matériaux précieux par des "frottements" pendant la mise en oeuvre. Aucune réclamation concernant le matériau posé ne sera acceptée.

REMARQUE:
Comme l'indique la norme UNI 11493.2013 paragraphe 5.2.2 : " l'examen visuel du carrelage doit être effectué à une distance minimum de 1,5 m, à hauteur d'homme. Ne pas utiliser d'éclairage à lumière oblique. Les effets de surface non détectables dans ces conditions ne sont pas à considérer comme des défauts".

Piemme décline toute responsabilité si les consignes de pose, de nettoyage et d'entretien ne sont pas respectées.

Pour toute information plus spécifique, prière de consulter la rubrique technique sur le site Piemme: www.ceramichepiemme.it

<p>Hinweise Für Die Verlegung</p>
<p>Für ein optimales Resultat mit rektifizierten Produkten empfehlen wir eine Fugenbreite von 2 mm.</p>
<p>Farblich auf die Fliesen abgestimmte Fugenmassen verbessern die Gesamtoptik.</p>
<p>Vor dem Verfugen ist die Kompatibilität der Fugenmassen mit den Keramikfliesen zu prüfen.</p>
<p>Überschüssige Fugenmasse entfernen, solange sie noch frisch ist.</p>
<p>Die Gebrauchshinweise der Fugenmassen-Hersteller sind strengstens einzuhalten. Zur vollständigen Entfernung der Verlegerückstände, die die normale Pflege und die Merkmale der Produkte beeinträchtigen könnten, die Fläche nach der Verlegung mit geeigneten, leicht sauren Produkten bis maximal 3 % Säuregehalt reinigen und dabei die Herstelleranweisungen befolgen. Es ist überaus wichtig, die in den Anweisungen angegebenen Einwirkzeiten nicht zu überschreiten: ein zu langer Kontakt mit diesen Produkten könnte die Fliesenoberfläche beschädigen.</p>
<p>Eventuelle Schleier, die nach der Verlegung von geläpptem oder geschliffenem Material auftreten könnten, lassen sich einfach mit einem geeigneten alkalischen Produkt entfernen.</p>
<p>Bei der Verlegung von Keramikmaterial im Freien sind trotz der Frostbeständigkeit der Feinzeugprodukte von Piemme gemäß den geltenden europäischen Richtlinien EN 14411/ISO ISO 13006, ISO 10545.12 einige grundlegende Normen zu beachten, die dazu dienen, die Bodenbeläge frostsicher zu machen. Die Hauptregeln lauten: angemessene Gefälle, Abdichtung, Dehnungsfugen, sowie geeignetes Verlegematerial.</p>
<p>*Dekore aus Glasuren und Edelmetallen:</p>
<p>Während der Verlegung sind die Oberflächen unbedingt abzudecken. Keinesfalls dürfen scheuernde und/oder saure Produkte verwendet werden, sondern ausschließlich Wasser und Neutralseife. Der Hersteller haftet nicht für eventuelle, durch Abrieb während der Verlegung entstandene Schäden an diesen hochwertigen Materialien. Derartige Beanstandungen des verlegten Materials werden nach der Verlegung in keinem Fall akzeptiert.</p>
<p>BEACHTÉ: Die Richtlinie UNI 11493.2013, Absatz 5.2.2 besagt: "Die Sichtkontrolle der gefliesten Fläche muss aus mindestens 1,5 m Abstand aus Augenhöhe erfolgen. Eine Flachwinkelbeleuchtung ist nicht zulässig. Unter diesen Bedingungen nicht erkennbare Oberflächeneffekte sind nicht als Fehler zu betrachten."</p>
<p>Bei Nichtbeachtung der obenstehenden Hinweise zu Verlegung, Reinigung und Pflege kann Piemme nicht haftbar gemacht werden.</p>
<p>Für weitergehende Informationen siehe den technischen Bereich der Piemme website: www.ceramichepiemme.it</p>

Für ein optimales Resultat mit rektifizierten Produkten empfehlen wir eine Fugenbreite von 2 mm.

Farblich auf die Fliesen abgestimmte Fugenmassen verbessern die Gesamtoptik.

Vor dem Verfugen ist die Kompatibilität der Fugenmassen mit den Keramikfliesen zu prüfen.

Überschüssige Fugenmasse entfernen, solange sie noch frisch ist.

Die Gebrauchshinweise der Fugenmassen-Hersteller sind strengstens einzuhalten. Zur vollständigen Entfernung der Verlegerückstände, die die normale Pflege und die Merkmale der Produkte beeinträchtigen könnten, die Fläche nach der Verlegung mit geeigneten, leicht sauren Produkten bis maximal 3 % Säuregehalt reinigen und dabei die Herstelleranweisungen befolgen. Es ist überaus wichtig, die in den Anweisungen angegebenen Einwirkzeiten nicht zu überschreiten: ein zu langer Kontakt mit diesen Produkten könnte die Fliesenoberfläche beschädigen.

Eventuelle Schleier, die nach der Verlegung von geläpptem oder geschliffenem Material auftreten könnten, lassen sich einfach mit einem geeigneten alkalischen Produkt entfernen.

Bei der Verlegung von Keramikmaterial im Freien sind trotz der Frostbeständigkeit der Feinzeugprodukte von Piemme gemäß den geltenden europäischen Richtlinien EN 14411/ISO ISO 13006, ISO 10545.12 einige grundlegende Normen zu beachten, die dazu dienen, die Bodenbeläge frostsicher zu machen. Die Hauptregeln lauten: angemessene Gefälle, Abdichtung, Dehnungsfugen, sowie geeignetes Verlegematerial.

*Dekore aus Glasuren und Edelmetallen:

Während der Verlegung sind die Oberflächen unbedingt abzudecken. Keinesfalls dürfen scheuernde und/oder saure Produkte verwendet werden, sondern ausschließlich Wasser und Neutralseife. Der Hersteller haftet nicht für eventuelle, durch Abrieb während der Verlegung entstandene Schäden an diesen hochwertigen Materialien. Derartige Beanstandungen des verlegten Materials werden nach der Verlegung in keinem Fall akzeptiert.

BEACHTÉ:
Die Richtlinie UNI 11493.2013, Absatz 5.2.2 besagt: "Die Sichtkontrolle der gefliesten Fläche muss aus mindestens 1,5 m Abstand aus Augenhöhe erfolgen. Eine Flachwinkelbeleuchtung ist nicht zulässig. Unter diesen Bedingungen nicht erkennbare Oberflächeneffekte sind nicht als Fehler zu betrachten."

Bei Nichtbeachtung der obenstehenden Hinweise zu Verlegung, Reinigung und Pflege kann Piemme nicht haftbar gemacht werden.

Für weitergehende Informationen siehe den technischen Bereich der Piemme website: www.ceramichepiemme.it

<p>Hinweise Für Die Verlegung</p>
<p>Für ein optimales Resultat mit rektifizierten Produkten empfehlen wir eine Fugenbreite von 2 mm.</p>
<p>Farblich auf die Fliesen abgestimmte Fugenmassen verbessern die Gesamtoptik.</p>
<p>Vor dem Verfugen ist die Kompatibilität der Fugenmassen mit den Keramikfliesen zu prüfen.</p>
<p>Überschüssige Fugenmasse entfernen, solange sie noch frisch ist.</p>
<p>Die Gebrauchshinweise der Fugenmassen-Hersteller sind strengstens einzuhalten. Zur vollständigen Entfernung der Verlegerückstände, die die normale Pflege und die Merkmale der Produkte beeinträchtigen könnten, die Fläche nach der Verlegung mit geeigneten, leicht sauren Produkten bis maximal 3 % Säuregehalt reinigen und dabei die Herstelleranweisungen befolgen. Es ist überaus wichtig, die in den Anweisungen angegebenen Einwirkzeiten nicht zu überschreiten: ein zu langer Kontakt mit diesen Produkten könnte die Fliesenoberfläche beschädigen.</p>
<p>Eventuelle Schleier, die nach der Verlegung von geläpptem oder geschliffenem Material auftreten könnten, lassen sich einfach mit einem geeigneten alkalischen Produkt entfernen.</p>
<p>Bei der Verlegung von Keramikmaterial im Freien sind trotz der Frostbeständigkeit der Feinzeugprodukte von Piemme gemäß den geltenden europäischen Richtlinien EN 14411/ISO ISO 13006, ISO 10545.12 einige grundlegende Normen zu beachten, die dazu dienen, die Bodenbeläge frostsicher zu machen. Die Hauptregeln lauten: angemessene Gefälle, Abdichtung, Dehnungsfugen, sowie geeignetes Verlegematerial.</p>
<p>*Dekore aus Glasuren und Edelmetallen:</p>
<p>Während der Verlegung sind die Oberflächen unbedingt abzudecken. Keinesfalls dürfen scheuernde und/oder saure Produkte verwendet werden, sondern ausschließlich Wasser und Neutralseife. Der Hersteller haftet nicht für eventuelle, durch Abrieb während der Verlegung entstandene Schäden an diesen hochwertigen Materialien. Derartige Beanstandungen des verlegten Materials werden nach der Verlegung in keinem Fall akzeptiert.</p>
<p>BEACHTÉ: Die Richtlinie UNI 11493.2013, Absatz 5.2.2 besagt: "Die Sichtkontrolle der gefliesten Fläche muss aus mindestens 1,5 m Abstand aus Augenhöhe erfolgen. Eine Flachwinkelbeleuchtung ist nicht zulässig. Unter diesen Bedingungen nicht erkennbare Oberflächeneffekte sind nicht als Fehler zu betrachten."</p>
<p>Bei Nichtbeachtung der obenstehenden Hinweise zu Verlegung, Reinigung und Pflege kann Piemme nicht haftbar gemacht werden.</p>
<p>Für weitergehende Informationen siehe den technischen Bereich der Piemme website: www.ceramichepiemme.it</p>

*Decori realizzati con smalti e metalli preziosi: E’ indispensabile proteggere la superficie durante la posa, non utilizzare assolutamente prodotti abrasivi e/o acidi, ma solo acqua e sapone neutro. Il produttore non risponde di eventuali danni a questi preziosi materiali causati da “sfregamenti” durante la posa in opera. Per nessun motivo saranno accettate contestazioni relative a materiale posato.

NOTA:
Come specificato dalla norma UNI 11493.2013 paragrafo 5.2.2: “l’esame visivo della superficie piastrellata deve essere effettuato da una distanza minima di 1,5 m ad altezza d’uomo. Non e’ consentita l’illuminazione in luce radente. Gli effetti superficiali non rilevabili in queste condizioni non sono da considerare come difetti”.
Piemme declina ogni responsabilità qualora non venissero rispettate le sopra citate norme di posa, pulizia e manutenzione.

Per ulteriori informazioni specifiche consultare l’area tecnica sul sito Piemme: www.ceramichepiemme.it

Norme di Posa

<p>قواعد التركيب</p>
<p>بالنسبة للمنتجات المصححة، نوصي بترك مسافة 2 مم للحصول على نتائج تركيب أفضل.</p>
<p>للحصول على ناتج جمالي أفضل، نوصي شركة بييمي "Piemme" بالجنص الملون مع البلاط.</p>
<p>تحقق قبل الاستخدام من توافق وملاءمة مواد ملء المسافات مع منتج السيراميك.</p>
<p>قم بإزالة زيادات مادة حشو المسافات قبل أن تجف.</p>

Per i prodotti rettificati consigliamo una fuga di 2 mm per un migliore risultato di posa. Per una migliore resa estetica Piemme consiglia stuccature colorate in tinta con le piastrelle. Verificare, prima dell'utilizzo, la compatibilità ed idoneità dei riempitivi per fughe con il prodotto ceramico. Rimuovere le eccedenze dei riempitivi per fughe quando gli stessi sono ancora freschi. Attenersi scrupolosamente alle istruzioni indicate dai produttori dei riempitivi per fughe. Per eliminare completamente i residui di posa, che potrebbero compromettere la manutenzione ordinaria e le caratteristiche del prodotto, a posa ultimata, procedere con la pulizia utilizzando prodotti adeguati, a base Acida max 3%, rispettando le indicazioni del produttore. Osservare assolutamente i limiti di tempo indicati nelle istruzioni: un contatto troppo prolungato con questi prodotti potrebbe provocare il danneggiamento della superficie.

Per i prodotti rettificati consigliamo una fuga di 2 mm per un migliore risultato di posa. Per una migliore resa estetica Piemme consiglia stuccature colorate in tinta con le piastrelle. Verificare, prima dell'utilizzo, la compatibilità ed idoneità dei riempitivi per fughe con il prodotto ceramico. Rimuovere le eccedenze dei riempitivi per fughe quando gli stessi sono ancora freschi. Attenersi scrupolosamente alle istruzioni indicate dai produttori dei riempitivi per fughe. Per eliminare completamente i residui di posa, che potrebbero compromettere la manutenzione ordinaria e le caratteristiche del prodotto, a posa ultimata, procedere con la pulizia utilizzando prodotti adeguati, a base Acida max 3%, rispettando le indicazioni del produttore. Osservare assolutamente i limiti di tempo indicati nelle istruzioni: un contatto troppo prolungato con questi prodotti potrebbe provocare il danneggiamento della superficie.

Gli eventuali aloni che si dovessero presentare dopo la posa di materiali lappati o levigati si potranno facilmente eliminare utilizzando un prodotto idoneo, a base Alcalina. Riguardo l'utilizzo di materiali ceramici all'esterno, pure riconfermando l'ingelività dei prodotti Piemme in gres porcellanato, in conformità alle vigenti normative europee EN 14411/ISO 13006-ISO 10545.12, occorre attenersi ad alcune fondamentali norme previste per la posa all'esterno, atte a rendere inattaccabili al gelo i predetti pavimenti. Le condizioni più importanti da rispettare sono: le opportune pendenze, le impermeabilizzazioni, i giunti di dilatazione, e l’uso di idonei materiali per la posa.

Per i prodotti rettificati consigliamo una fuga di 2 mm per un migliore risultato di posa. Per una migliore resa estetica Piemme consiglia stuccature colorate in tinta con le piastrelle. Verificare, prima dell'utilizzo, la compatibilità ed idoneità dei riempitivi per fughe con il prodotto ceramico. Rimuovere le eccedenze dei riempitivi per fughe quando gli stessi sono ancora freschi. Attenersi scrupolosamente alle istruzioni indicate dai produttori dei riempitivi per fughe. Per eliminare completamente i residui di posa, che potrebbero compromettere la manutenzione ordinaria e le caratteristiche del prodotto, a posa ultimata, procedere con la pulizia utilizzando prodotti adeguati, a base Acida max 3%, rispettando le indicazioni del produttore. Osservare assolutamente i limiti di tempo indicati nelle istruzioni: un contatto troppo prolungato con questi prodotti potrebbe provocare il danneggiamento della superficie.

Gli eventuali aloni che si dovessero presentare dopo la posa di materiali lappati o levigati si potranno facilmente eliminare utilizzando un prodotto idoneo, a base Alcalina. Riguardo l'utilizzo di materiali ceramici all'esterno, pure riconfermando l'ingelività dei prodotti Piemme in gres porcellanato, in conformità alle vigenti normative europee EN 14411/ISO 13006-ISO 10545.12, occorre attenersi ad alcune fondamentali norme previste per la posa all'esterno, atte a rendere inattaccabili al gelo i predetti pavimenti. Le condizioni più importanti da rispettare sono: le opportune pendenze, le impermeabilizzazioni, i giunti di dilatazione, e l’uso di idonei materiali per la posa.

<p>قواعد التركيب</p>
<p>بالنسبة للمنتجات المصححة، نوصي بترك مسافة 2 مم للحصول على نتائج تركيب أفضل.</p>
<p>للحصول على ناتج جمالي أفضل، نوصي شركة بييمي "Piemme" بالجنص الملون مع البلاط.</p>
<p>تحقق قبل الاستخدام من توافق وملاءمة مواد ملء المسافات مع منتج السيراميك.</p>
<p>قم بإزالة زيادات مادة حشو المسافات قبل أن تجف.</p>

For rectified products, we suggest a 2 mm joint for better installation results.

For better aesthetic results, Piemme suggests using jointing putty in the same colour as the tiles. Before using, make sure the jointing putty is compatible with the ceramic product and suitable for use. Remove any excess jointing putty while this is still fresh.

Carefully follow the instructions provided by the jointing putty manufacturer.

To completely eliminate installation residues that could affect routine maintenance and characteristics of the product, after installation, proceed to clean using suitable products with max 3% acid base, following the manufacturer’s instructions. Stringently comply with the time limits indicated in the instructions. If these products remain in contact with surfaces for too long the latter could become damaged.

Any rings that appear after installing lapped or polished materials can be easily eliminated using a suitable alkaline-based product. With regard to the use of ceramic materials outdoors, while we confirm that Piemme porcelain stoneware products are frost-proof, in compliance with applicable European EN 14411/ISO 13006-ISO 10545.12 standards, certain basic procedures must be followed for outdoor installation, so that such floors cannot be attacked by frost. The most important aspects of such outdoor installation are: suitable gradients, waterproofing, expansion joints and the use of suitable installation materials.

*Decors made with glazes and precious metals: Surfaces must be protected during installation. Never use abrasive and/or acid products, only water and neutral soap. The manufacturer disclaims liability for damage to these precious materials caused by “rubbing” during installation. Under no circumstances can disputes be accepted relating to installed materials.

NOTE:
As specified in the UNI 11493.2013 standard at paragraph 5.2.2 : “the visual inspection of the tiled surface must be made at a distance of 1.5 m at the height of a person. No side-lighting is allowed. Surface effects not visible in these conditions are not to be deemed as defects”.

Piemme disclaims all liability in the event of the above installation, cleaning and maintenance rules not being followed.

For more specific details, visit the technical area of the Piemme website: www.ceramichepiemme.it

Gres Fine Porcellanato

È la suprema sintesi di tecnica ed estetica. La scelta delle migliori materie prime, la cottura a 1250° C e l'intero controllo del ciclo produttivo assicurano infatti a questi materiali caratteristiche tecniche di assoluto rilievo, rendendoli estremamente duri, inassorbenti, ingelivi, resistenti all'usura, agli attacchi chimici e facilmente pulibili. Classificazione secondo norme CEN/ISO gruppo BIA EN 14411/ISO 13006.

Porcelain Stoneware

Piemme fine porcelain stoneware is a supreme blend of technology and good looks. The choice of the very best raw materials, firing at 1250° c and total manufacturing cycle control do in fact provide these materials with top-ranking technical features, making them hard, non-absorbent, frost-proof, resistant to wear and chemical attack and easy to clean. Classification in accordance with cen/iso standards BIA EN 14411/ISO 13006

Feinsteinzeug

Das Feinsteinzeug Piemme ist eine vortreffliche Verschmelzung von Technik und Ästhetik. Denn die Wahl bester Rohstoffe, der Brand bei 1250° C und die gesamte Kontrolle des Produktionszyklus garantieren für diese Fliesen hervorragende technische Eigenschaften. Das Material ist hart, absorptionsfrei, frostbeständig, verschleiß- und chemikalienfest sowie reinigungsfreundlich. Klassifizierung gemäß CEN/ISO Normen Gruppe BIA EN 14411/ISO 13006.

Grès Cérame

Le grès cérame fin Piemme est l'alliance par excellence de la technique et de l'esthétique. En effet, le choix des meilleures matières premières, la cuisson à 1250° C et tous les contrôles effectués pendant la production assurent à ces matériaux des caractéristiques techniques tout à fait remarquables, les rendent extrêmement durs, inabsorbants, ingélifs, résistant à l'usure, aux attaques chimiques et faciles à nettoyer. Classification selon les normes CEN/ISO groupe BIA EN 14411/ISO 13006

Фарфоровый керамогранит

Это – наивысшее выражение техники и эстетики. Выбор наилучшего сырья, обжиг при 1250°С и полный контроль производственного цикла гарантируют этим материалам выдающиеся технические характеристики, делая их чрезвычайно твердыми, не впитывающими влагу, незамерзающими, стойкими к износу и химическому воздействию, легко очищаемыми. Классификация по стандартам CEN/ISO: группа BIA EN 14411/ISO 13006.

Pasta Bianca

La pasta bianca è la naturale evoluzione del rivestimento. L'alta qualità dei materiali, le alte temperature di cottura permettono di ottenere bellezza di superfici e grandi formati da rivestimento. Classificazione secondo norme CEN/ISO gruppo BIII EN 14411/ISO 13006.

White Body

The natural evolution of wall tile. The fine quality of materials, the high firing temperatures achieve beauty of surfaces and big sizes in wall tiles.

Classification in accordance with CEN/ISO standards BIII EN 14411/ISO 13006.

Weißscherbig

Die natürliche Entwicklung der Wandfliese. Die ausgezeichnete Materialienqualität, die hohe Brenntemperaturen erwirken Oberflächen-Schönheit und große Formate bei Wandfliesen.

Klassifizierung gemäß CEN/ISO Normen Gruppe BIII EN 14411/ISO 13006.













Pâte Blanche











Naturelle évolution du revêtement. La haute qualité des matériaux, les températures élevées de cuisson permettent d'obtenir la beauté des surfaces et de grands formats pour revêtement.

Classification selon les normes CEN/ISO groupe BIII EN 14411/ISO 13006.

Плитка Из Белой Глины

Плитка из белой глины – это естественная эволюция облицовочной плитки. Высокое качество материалов и высокая температура обжига позволяют получать красивые поверхности и большие форматы облицовочного материала. Классификация по стандартам CEN/ISO: группа BIII EN 14411/ISO 13006.

CLASSIFICAZIONE SECONDO NORME CEN/ISO GRUPPO BIA EN 14411/ISO 13006. CLASSIFICATION IN ACCORDANCE WITH CEN/ISO STANDARDS BIA EN 14411/ISO 13006. KLASSIFIZIERUNG GEMÄSS CEN/ISO NORMEN GRUPPE BIA EN 14411/ISO 13006. CLASSIFICATION SELON LES NORMES CEN/ISO GROUPE BIA EN 14411/ISO 13006.		*VALORE PRESCRITTO: EN 14411 APPENDICE G - ISO 13006 - BIA *REQUIRED VALUE: EN 14411 APPENDICE G - ISO 13006 - BIA *VORGESCHRIEBENER WERT: EN 14411 APPENDICE G - ISO 13006 - BIA *VALEUR PRESCRITE: EN 14411 APPENDICE G - ISO 13006 - BIA			
Proprietà Fisico-Chimiche Physical-Chemical Properties Pysisch-Chemische Eigenschaften Propriétés Physico-Chimiques	Tipo Di Prova Standard Of Test Testnorm Norme Du Test	Valore Prescritto* Required Value Vorgeschriebener Wert Valeur Prescrite	Valore Standards Standard Ergebnis Valeur	Norme Norm Normr	Valore medio Mean value Mittelwert Valeur moyenne
 Lunghezza e larghezza Lenght and width Länge und breite Longueur et largeur	Iso 10545.2	± 0,6% (± 2,00 mm)	Conforme In accordance Erfüllt Conforme	Astm C-499 Astm C-485 Astm C-502	In Accordance
 Ortogonalità Wedging Rechtwinkligkeit Orthogonalität	Iso 10545.2	± 0,5% (± 2,00 mm)	Conforme In accordance Erfüllt Conforme	Astm C-499 Astm C-485 Astm C-502	In Accordance
 Spessore Thickness Stärke Epaisseur	Iso 10545.2	± 5% (± 0,50 mm)	Conforme In accordance Erfüllt Conforme	Astm C-499 Astm C-485 Astm C-502	In Accordance
 Planarità Flatness Ebenflächigkeit Planéité	Iso 10545.2	± 0,5% (± 2,00 mm)	Conforme In accordance Erfüllt Conforme	Astm C-499 Astm C-485 Astm C-502	In Accordance
 Assorbimento d'acqua Water absorption Wasseraufnahme Absorption d'eau	Iso 10545.3	≤ 0,5%	Conforme In accordance Erfüllt Conforme	Astm C-373	In Accordance
 Coefficiente di dilatazione termica lineare Coefficient of linear thermal-expansion Lineare wärmeausdehnung Coefficient linéaire de dilatation thermique	Iso 10545.8	Secondo i dati del costruttore According to builder's specifications Lautangaben des herstelllers Selon les elements du constructeur	≈ 7X10-6 C-1		
 Resistenza a flessione Flexion resistance Biegezugfestigkeit Résistance à la flexion	Iso 10545.4	Modulus of rupture (average): ≥ 35 N/mm² Breaking strength for thickness ≥7,5mm: S >1300 N	Conforme In accordance Erfüllt Conforme	Astm C-648 250 Lbs or greater	In Accordance
 Resistenza agli sbalzi termici Thermal shock resistance Temperaturwechselbeständigkeit Résistance aux écarts de température	Iso 10545.9	Richiesta Request Bitte Demande	Resistente Resistant Widerstehend Résistant		
 Resistenza ai prodotti chimici Chemical resistance Chemikalienfestigkeit Résistance aux produits chimiques	Iso 10545.13	Secondo i dati del costruttore According to builder's specifications Lautangaben des herstelllers Selon les elements du constructeur	Resistente Resistant Widerstehend Résistant	Astm C-650	In Accordance
 Resistenza al gelo Frost resistance Frostbeständigkeit Résistance au gel	Iso 10545.12	Richiesta Requested Angefordert Demande	Resistente Resistant Widerstehend Résistant	Astm C-1026	In Accordance
 Resistenza dei colori alla luce Colour resistance to light Lichtbeständigkeit der farben Résistance des couleurs à la lumière	Din 51094	Nessuna alterazione No alteration Keine veränderung Aucune altération	Conforme In accordance Erfüllt Conforme		
 Resistenza allo scivolamento Slip resistance Rutschfestigkeit Résistance à la glissance	Din 51130 Din 51097	Secondo i dati del costruttore According to builder's specifications Lautangaben des herstelllers Selon les elements du constructeur	Indicata sul catalogo indicated on the catalogue im prospekt angegeben indique sur le catalogue	Astm C-1028 Ansi Dcof 137.1 - 2012	Available on request

CLASSIFICAZIONE SECONDO NORME CEN/ISO GRUPPO BIII EN 14411/ISO 13006. CLASSIFICATION IN ACCORDANCE WITH CEN/ISO STANDARDS BIII EN 14411/ISO 13006. KLASSIFIZIERUNG GEMÄSS CEN/ISO NORMEN GRUPPE BIII EN 14411/ISO 13006. CLASSIFICATION SELON LES NORMES CEN/ISO GROUPE BIII EN 14411/ISO 13006.		*VALORE PRESCRITTO: EN 14411 APPENDICE L ISO 13006 BIII *REQUIRED VALUE: EN 14411 APPENDICE L ISO 13006 BIII *VORGESCHRIEBENER WERT: EN 14411 APPENDICE L ISO 13006 BIII *VALEUR PRESCRITE: EN 14411 APPENDICE L ISO 13006 BIII	
Proprietà Fisico-Chimiche Physical-Chemical Properties Pysisch-Chemische Eigenschaften Propriétés Physico-Chimiques	Tipo Di Prova Standard Of Test Testnorm Norme Du Test	Valore Prescritto* Required Value Vorgeschriebener Wert Valeur Prescrite	Valore Standards Standard Ergebnis Valeur
 Lunghezza e larghezza Lenght and width Länge und breite Longueur et largeur	Iso 10545.2	± 0,5%	± 0,5%
 Ortogonalità Wedging Rechtwinkligkeit Orthogonalität	Iso 10545.2	± 0,5%	± 0,5%
 Spessore Thickness Stärke Epaisseur	Iso 10545.2	± 10%	Conforme In accordance Erfüllt Conforme
 Planarità Flatness Ebenflächigkeit Planéité	Iso 10545.2	+ 0,5% - 0,3%	+ 0,5% - 0,3%
 Assorbimento d'acqua Water absorption Wasseraufnahme Absorption d'eau	Iso 10545.3	> 10%	≈ 16%
 Coefficiente di dilatazione termica lineare Coefficient of linear thermal-expansion Lineare wärmeausdehnung Coefficient linéaire de dilatation thermique	Iso 10545.8	Secondo i dati del costruttore According to builder's specifications Lautangaben des herstelllers Selon les elements du constructeur	≈ 6X10-6 C-1
 Resistenza a flessione spessore Flexion resistance thickness Biegezugfestigkeit stärke Résistance à la flexion epaisseur	Iso 10545.4	≥ 7,5 mm 12 N/mm² < 7,5 mm 15 N/mm²	Garantita Guaranteed Garantiert Garantie
 Resistenza agli sbalzi termici Thermal shock resistance Temperaturwechselbeständigkeit Résistance aux écarts de température	Iso 10545.9	Metodo di prova disponibile Test method available Verfügbare prüfmethode Methode d'essai disponible	Garantita Guaranteed Garantiert Garantie
 Resistenza ai prodotti chimici Chemical resistance Chemikalienfestigkeit Résistance aux produits chimiques	Iso 10545.13	Metodo di prova disponibile Test method available Verfügbare prüfmethode Methode d'essai disponible	Disponibile Su Richiesta Available On Request Verfügbare Auf Anfrage Disponible Sur Demande
 Resistenza al gelo Frost resistance Frostbeständigkeit Résistance au gel	Iso 10545.12	Metodo di prova disponibile Test method available Verfügbare prüfmethode Methode d'essai disponible	No No Nein Non
 Resistenza al cavillo Crazing resistance Haarissbeständigkeit Résistance au tressillage	Iso 10545.11	Richiesta Request Bitte Demande	Garantita Guaranteed Garantiert Garantie

Certificazioni

Certifications



ENVIRONMENTAL AND QUALITY SYSTEM MANAGEMENT
Nel corso della propria evoluzione impiantistica Industrie Ceramiche Piemme ha sempre coniugato esigenze di carattere tecnico e produttivo con scelte ecocompatibili, alla continua ricerca di un prodotto che soddisfi le richieste e le aspettative della propria clientela. Industrie Ceramiche Piemme è un'azienda moderna con sistema di gestione certificato ai sensi della norma UNI EN ISO 9001 per la Qualità e UNI EN ISO 14001 per l'Ambiente. L'adozione di modelli standard di riferimento internazionale risponde alla crescente richiesta di competitività, raggiunta attraverso il miglioramento della soddisfazione e della fidelizzazione dei clienti, la razionalizzazione dei processi interni e la conseguente riduzione di sprechi e inefficienze, minimizzando l'impatto ambientale dei processi e prodotti, nel rispetto delle norme.



ENVIRONMENTAL AND QUALITY SYSTEM MANAGEMENT
When developing its systems, Industrie Ceramiche Piemme has always combined technical and production requirements with eco-friendly choices, in its continuous quest to produce products that meet the requirements and expectations of its clientele. Industrie Ceramiche Piemme is a modern company with a management system certified pursuant to the UNI EN ISO 9001 standard for Quality and the UNI EN ISO 14001 standard for the Environment. The implementation of standard models that are recognised internationally is a response to the growing demand for competitiveness, achieved by improving levels of customer satisfaction and loyalty, rationalising in-house processes and consequently reducing waste and inefficiency, and minimising the environmental impact of the processes and products, in compliance with the legislation in force.



ENERGY AND SAFETY SYSTEM MANAGEMENT
Nel 2022 il Sistema di Gestione di Industrie Ceramiche Piemme ha superato le verifiche di conformità ottenendo le importanti Certificazioni ISO 45001 e ISO 50001. Queste due certificazioni, che si vanno ad aggiungere alle precedenti sulla Qualità (ISO 9001) e sull'Ambiente (ISO 14001) sono strategiche per il percorso aziendale in continuo rinnovamento ed innovazione. La prima, la Certificazione ISO 45001, è relativa ai temi della salute e della sicurezza in azienda: questa certificazione attesta che il sistema interno di gestione della sicurezza, oltre ad essere conforme alle normative, è organizzato per perseguire il miglioramento continuo e la riduzione dei fattori di rischio, al fine di tutelare la salute e la sicurezza dei lavoratori. La seconda, la Certificazione ISO 50001, è relativa al tema dell'efficiamento energetico: con questa certificazione l'Azienda ha dimostrato di avere un sistema di gestione dell'energia rispondente alle normative di settore, capace di garantire i seguenti obiettivi: aumentare l'efficienza dei processi, migliorare le prestazioni energetiche puntuali e globali, ridurre i costi specifici dei vettori energetici.



ENERGY AND SAFETY SYSTEM MANAGEMENT
In 2022, the Management System of Industrie Ceramiche Piemme passed the compliance checks, obtaining the important ISO 45001 and ISO 50001 Certifications. These two certifications, which are added to the previous ones on Quality (ISO 9001) and Environment (ISO 14001) are strategic for the company path in continuous renewal and innovation. The first, the ISO 45001 Certification, relates to issues of health and safety in the company: this certification certifies that the internal system of safety management, in addition to being compliant with regulations, is organized to pursue continuous improvement and the reduction of risk factors in order to protect the health and safety of workers. The second, the ISO 50001 Certification, relates to the theme of energy efficiency: with this certification, the Company has proven to have an energy management system that complies with industry regulations, able to guarantee the following objectives: increase process efficiency, improve punctual and global energy performance, reduce the specific costs of energy carriers.



Industrie Ceramiche Piemme è socio ordinario del GBC Italia (Green Building Council Italia), associazione no profit nata per favorire e promuovere lo sviluppo dell'edilizia sostenibile e sensibilizzare l'opinione pubblica e le istituzioni sull'impatto che le modalità di progettazione e costruzione degli edifici hanno sulla qualità della vita dei cittadini. I prodotti realizzati da Industrie Ceramiche Piemme contengono materiale riciclato pre-consumer, con un valore percentuale certificato da un Ente riconosciuto a livello internazionale, e che consente di concorrere al raggiungimento dei crediti LEED relativi alla costruzione di edifici eco-sostenibili.



Industrie Ceramiche Piemme is an ordinary member of the GBC Italia (Green Building Council Italia), a no-profit association founded to favour and promote the development of sustainable construction and raise public awareness, and that of the institutions, on the impact that the methods used to design and construct buildings have on the citizens' quality of life. The products made by Industrie Ceramiche Piemme contain pre-consumer recycled material, with a percentage value that is certified by an internationally recognised Authority, and qualifies for the purposes of acquiring LEED credits for the construction of eco-sustainable buildings.



FDES
La certificazione FDES costituisce la carta d'identità ambientale dei prodotti, basata sui risultati della relativa Analisi del Ciclo di Vita (LCA) e secondo la norma NF EN 15804+A1 e dal suo supplemento nazionale NF EN 15804/CN. L'Analisi del Ciclo di Vita (LCA) è un metodo strutturato e standardizzato a livello internazionale che permette di quantificare i potenziali impatti sull'ambiente e sulla salute umana associati a un bene o servizio, a partire dal rispettivo consumo di risorse e dalle emissioni.



FDES
FDES certification defines the environmental identity card of products. It is based on the results of the relevant Life Cycle Analysis (LCA) and is based on the NF EN 15804+A1 standard and its national supplement NF EN 15804/CN. Life Cycle Analysis (LCA) is an internationally standardized evaluation method that quantifies the impacts of a product, service, or process over the span of its life cycle, from extracting raw materials to the end-of-life processing, on the potential impacts on the environment and human health.



HPD
Industrie Ceramiche Piemme ha adottato lo standard collaborativo HPD Dichiarazioni di Salubrità di Prodotto (Health Product Declarations), per comunicare in modo trasparente il contenuto dei propri materiali e il relativo impatto sulla salute. Grazie all'HPD, i nostri prodotti contribuiscono all'ottenimento di crediti LEED® e WELL™.



HPD
Industrie Ceramiche Piemme has adopted the HPD (Health Product Declarations) collaborative standard to communicate the contents of its materials and the related impact on health in a transparent manner. Thanks to HPD, our products contribute towards obtaining LEED® and WELL™ credits.



Le piastrelle prodotte da Industrie Ceramiche Piemme sono inerti da un punto di vista chimico-fisico e durante il loro ciclo di utilizzo, dalla posa fino all'eventuale dismissione, non rilasciano in atmosfera composti organici volatili (COV o VOC (Volatile Organic Compounds)). I materiali Piemme sono pertanto conformi alle prescrizioni normative in materia di COV e consentono di ottenere i crediti previsti dallo standard LEED (Leadership in Energy and Environmental Design).



The tiles produced by Industrie Ceramiche Piemme are physically and chemically inert, and during their cycle of use, from laying to removal, if applicable, they do not release Volatile Organic Compounds (COVs or VOCs) into the atmosphere. Piemme materials therefore comply with the terms of the legislation regarding COVs and qualify for the purposes of acquiring the credits envisaged by the LEED standard (Leadership in Energy and Environmental Design).



Numerose serie prodotte da Industrie Ceramiche Piemme vantano la certificazione UPEC, il marchio di qualità francese rilasciato in base ai test previsti dalla normativa europea EN 14411 e dai Cahiers tecnici dell'istituto CSTB. Ad ogni articolo viene assegnata una classificazione che ne attribuisce l'idoneità all'installazione nei diversi ambienti di destinazione.



Many series produced by Industrie Ceramiche Piemme are certified UPEC, the French quality mark issued based on the tests envisaged by the European standard EN 14411 and by the technical Cahiers of the CSTB institute. Each item is assigned with a classification that determines its suitability for installation in various fields of use.



CCC (China Compulsory Certificate) è un marchio di sicurezza obbligatorio per molti prodotti venduti sul mercato cinese.



The CCC (China Compulsory Certificate) is a safety certificate that is compulsory for many products sold on the Chinese market.



SASO QUALITY MARK
È un marchio di qualità obbligatorio per le esportazioni in Arabia Saudita. Il marchio, approvato dall'Organizzazione per gli Standard dell'Arabia Saudita (Saudi Arabian Standards Organization - SASO) indica la conformità di un prodotto agli standard del Paese. I prodotti di Industrie Ceramiche Piemme SpA rispondono agli standard ed ai requisiti definiti dalla norma internazionale SASO ISO 13006:2018 (Piastrine ceramiche - Definizioni, classificazione, caratteristiche e marcatura).



SASO QUALITY MARK
A quality mark compulsory for exports to Saudi Arabia. The mark, approved by the Saudi Arabian Standards Organization - SASO, confirms a product's compliance with the country's standards. Industrie Ceramiche Piemme S.p.A. products conform to the standards and requirements established by the SASO ISO 13006:2018 international standard (Ceramic tiles – Definitions, classification, characteristics and marking).



Thai Industrial Standards Institute (TISI) è una certificazione di prodotto obbligatoria per le esportazioni in Thailandia. Il suo conseguimento garantisce il rispetto dei requisiti di prodotto fissati dagli standard thailandesi.



Thai Industrial Standards Institute (TISI) is a mandatory certification for exports to Thailand. Its achievement compliance with the product requirements set by Thai standards.



Gli articoli realizzati da Industrie Ceramiche Piemme S.p.A. sono conformi al Regolamento N° 305/2011 che definisce le modalità attraverso le quali i produttori di materiali da costruzione devono dichiarare le prestazioni dei prodotti immessi sul mercato. Si tratta di una dichiarazione di conformità a tutela della sicurezza del consumatore, senza la quale il prodotto non può circolare all'interno dei confini dell'Unione Europea. La presenza sull'imballo della Marcatura CE garantisce che Industrie Ceramiche Piemme abbia ottemperato alle disposizioni comunitarie vigenti per l'immissione sul mercato dei prodotti da costruzione.

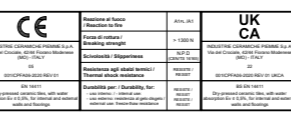

The items manufactured by Industrie Ceramiche Piemme S.p.A. comply with Regulation No. 305/2011, which defines the ways in which the producers of building materials must declare the performances of any products introduced to the market. It is a declaration of conformity designed to protect the consumer's safety and without it, the product cannot circulate within the confines of the European Union. The presence of the CE Mark on the packaging guarantees that Industrie Ceramiche Piemme has complied with the European Community provisions in force governing the introduction of building products to the market.

Elenco delle serie certificate e classificazioni disponibili a richiesta.
Schede tecniche delle serie certificate disponibili sul sito: www.ceramichepiemme.it

List of certified series and classification available upon request.
Technical boards of certified series available on the website: www.ceramichepiemme.it

Certifications



GESTION DU SYSTÈME ENVIRONNEMENTAL ET QUALITÉ
 Tout au long de son développement, Industrie Ceramiche Piemme a toujours associé les nécessités techniques et productives aux exigences éco-compatibles en s'engageant dans la recherche continue d'un produit satisfaisant les attentes de sa clientèle. Industrie Ceramiche Piemme est une entreprise moderne disposant d'un système de gestion certifié conformément à la norme UNI EN ISO 9001 pour la Qualité et UNI EN ISO 14001 pour l'Environnement. L'adoption de standards internationaux répond à la demande de compétitivité croissante, satisfaite à travers l'amélioration de la satisfaction et de la fidélisation des clients, la rationalisation des processus internes et la réduction conséquente du gaspillage et des inefficiences afin de réduire au minimum l'impact des processus de production sur l'environnement, dans le respect de la réglementation.



GESTION DES SYSTÈMES D'ÉNERGIE ET DE SÉCURITÉ
 En 2022, le système de gestion d'Industrie Ceramiche Piemme a passé les contrôles de conformité, obtenant les importantes certifications ISO 45001 et ISO 50001. Ces deux certifications, qui s'ajoutent aux précédentes sur la Qualité (ISO 9001) et sur l'Environnement (ISO 14001) sont stratégiques pour le cheminement de l'entreprise dans le renouvellement et l'innovation continus. La Certification ISO 45001, concerne les enjeux de santé et de sécurité de l'entreprise : celle-ci établit que le système interne de management de la sécurité est organisé pour poursuivre l'amélioration continue et la réduction des facteurs de risques afin de protéger la santé et la sécurité des travailleurs en plus d'être conforme à la réglementation. Deuxièmement la Certification ISO 50001, porte sur la problématique de l'efficacité énergétique : avec cette dernière, l'Entreprise a démontré qu'elle dispose d'un système de management de l'énergie conforme à la réglementation sectorielle, capable de garantir les objectifs suivants : augmenter l'efficacité des processus, améliorer performances énergétiques ponctuelles et globales, réduire les coûts spécifiques des vecteurs énergétiques.



Industrie Ceramiche Piemme est membre ordinaire du gbc italia (green building council italia), l'association à but non lucratif créée pour favoriser et promouvoir le développement de bâtiments à haute qualité environnementale, ainsi que pour sensibiliser l'opinion publique et les institutions sur l'impact que la conception et la construction des bâtiments ont sur la qualité de la vie des citoyens. Les carreaux fabriqués par Industrie Ceramiche Piemme sont issus de matériaux recyclés "pré-consommation", dont le pourcentage est certifié par une entité reconnue internationalement, et qui permet d'acquérir les crédits LEED pour la construction de bâtiments durables.



FDES
 La certification FDES constitue la carte d'identité environnementale des produits, basée sur les résultats de l'Analyse de Cycle de Vie (ACV) pertinente et selon la norme NF EN 15804+A1 et son complément national NF EN 15804/CN. L'Analyse du Cycle de Vie (ACV) est une méthode structurée et standardisée au niveau international qui permet de quantifier les impacts potentiels sur l'environnement et la santé humaine associés à un bien ou un service, à partir de la consommation respective de ressources et d'émissions.



HPD
 Industrie Ceramiche Piemme a adopté la norme collaborative HPD pour les déclarations de salubrité des produits (Health Product Declarations), pour transmettre de manière transparente le contenu de ses matériaux et l'impact sur la santé. Grâce à la norme HPD, nos produits contribuent à l'obtention des crédits LEED® et WELL™.



Les carreaux fabriqués par Industrie Ceramiche Piemme sont inertes d'un point de vue chimique et physique. Pendant toute leur durée de vie, de la pose jusqu'à la mise au rebut, ils n'émettent aucun composé organique volatil (COV ou VOC (Volatile Organic Compounds) dans l'atmosphère. Ils sont donc conformes aux exigences réglementaires en matière de COV et permettent d'obtenir les crédits prévus par le standard LEED (Leadership in Energy and Environmental Design).



De nombreuses lignes produites par Industrie Ceramiche Piemme sont certifiées UPEC, la marque de qualité française délivrée après avoir passé les tests prévus par la norme européenne EN 14411 et par les cahiers techniques de l'Institut CSTB. Un classement est attribué à chaque article qui en définit l'aptitude à la pose selon la destination.



CCC (China Compulsory Certificate) est une marque de sécurité obligatoire pour de nombreux produits vendus sur le marché chinois.



LABEL DE QUALITÉ SASO
 SASO est un label de qualité obligatoire pour les exportations à destination de l'Arabie saoudite. Le label, approuvée par la Saudi Arabian Standards Organization (SASO), indique la conformité d'un produit aux normes du pays. Les produits de Industrie Ceramiche Piemme S.p.A. répondent aux normes et aux exigences définies par la norme internationale SASO ISO 13006:2018 (Carreaux et dalles céramiques - Définitions, classification, caractéristiques et marquage).



Thai Industrial Standards Institute (TISI) est une certification de produit obligatoire pour les exportations en Thaïlande. Son obtention garantit le respect des obligations de produit fixés des standard thaïlandais.



Les carreaux fabriqués par Industrie Ceramiche Piemme S.p.A. sont conformes au Règlement n° 305/2011 qui définit les modalités à travers lesquelles les producteurs de matériaux de construction doivent déclarer les performances des produits qu'ils présentent sur le marché. Il s'agit d'une déclaration de conformité assurant la sécurité du consommateur, sans laquelle le produit ne pourrait pas circuler au sein des frontières de l'Union européenne. Le marquage CE appliqué sur l'emballage est la garantie que Industrie Ceramiche Piemme a satisfait aux dispositions européennes en vigueur réglementant la circulation des matériaux de construction au sein de l'UE.

Liste des séries certifiées et des classements disponibles sur demande.
 Fichier technic des séries certifiées disponibles sur le site web: www.ceramichepiemme.it

Zertifizierungen



UMWELT- UND QUALITÄTSSYSTEMMANAGEMENT
 Im Laufe seiner anlagentechnischen Entwicklung hat Industrie Ceramiche Piemme stets technische bzw. Produktionstechnische Erfordernisse mit umweltbewussten Entscheidungen in Einklang gebracht, im kontinuierlichen Streben nach einem Produkt, das die Wünsche und Erwartungen der Kunden erfüllt. Industrie Ceramiche Piemme ist ein modernes Unternehmen mit einem nach UNI EN ISO 9001 für die Qualität und nach UNI EN ISO 14001 für die Umwelt zertifizierten Managementsystem. Die Anwendung international anerkannter Standardmodelle entspricht dem zunehmenden Bedarf an Wettbewerbsfähigkeit. Diese wiederum wird durch Verbesserung der Kundenzufriedenheit und -bindung, rationelle interne Abläufe und die damit erzielte Reduzierung von Verschwendung und Ineffizienz, sowie durch eine normengerechte Reduzierung der Umweltwirkung von Prozessen und Produkten auf das Minimum erreicht.



ENERGIE- UND SICHERHEITSSYSTEMMANAGEMENT
 Im Jahr 2022 hat das Managementsystem von Industrie Ceramiche Piemme die Konformitätsprüfungen bestanden und die wichtigen Zertifizierungen ISO 45001 und ISO 50001 erhalten. Diese beiden Zertifizierungen, die zu den vorherigen für Qualität (ISO 9001) und Umwelt (ISO 14001) hinzugefügt werden, sind strategisch für den Weg des Unternehmens in fortlaufende Erneuerung und Innovation. Die erste, die ISO 45001-Zertifizierung, bezieht sich auf das Gesundheitswesen und Sicherheit im Unternehmen: diese Zertifizierung bescheinigt, dass das interne Sicherheitsmanagementsystem nicht nur den Vorschriften entspricht, sondern auch darauf ausgerichtet ist, eine kontinuierliche Verbesserung und die Reduzierung von Risikofaktoren zu verfolgen, um die Gesundheit und Sicherheit der Arbeitnehmer zu schützen. Die zweite, die ISO 50001-Zertifizierung, bezieht sich auf das Thema Energieeffizienz: mit dieser Zertifizierung hat das Unternehmen nachgewiesen, dass es über ein Energiemanagementsystem verfügt, das den branchenspezifischen Vorschriften entspricht und in der Lage ist, die folgenden Ziele zu gewährleisten: Steigerung der Prozesseffizienz, Verbesserung der punktuellen und globalen Energieleistung, Reduktion der spezifischen Kosten der Energieträger.



Industrie Ceramiche Piemme ist ordentliches Mitglied des GBC Italia (Green Building Council Italien), einer Non-Profit-Organisation für die Förderung des nachhaltigen Bauens und die Sensibilisierung der öffentlichen Meinung und der Behörden für die Wirkung, die die Art und Weise, wie Gebäude geplant und gebaut werden, auf die Lebensqualität der Bürger haben. Die von Industrie Ceramiche Piemme hergestellten Produkte enthalten Pre-Consumer-Recyclingmaterial, dessen Anteil durch eine international anerkannte Prüfstelle zertifiziert ist und das bei der Vergabe der LEED-Punkte den Bau ökologisch nachhaltiger Gebäude angerechnet wird.



FDES
 Die FDES-Zertifizierung stellt die Umweltidentitätskarte der Produkte dar, basierend auf den Ergebnissen der entsprechenden Lebenszyklusanalyse (LCA) und gemäß der Norm NF EN 15804+A1 und der nationalen Ergänzung NF EN 15804/CN. Die Lebenszyklusanalyse (LCA) ist eine strukturierte und international standardisierte Methode, die es ermöglicht, ausgehend vom jeweiligen Ressourcenverbrauch und den Emissionen, die potenziellen Auswirkungen einer Ware oder Dienstleistung auf die Umwelt und die menschliche Gesundheit zu messen.



HPD
 Industrie Ceramiche Piemme hat den kollaborativen HPD-Standard für Produktgesundheitsdeklarationen übernommen (Health Product Declarations), um den Inhalt der eigenen Artikel und die damit verbundenen Auswirkungen auf die Gesundheit transparent zu kommunizieren. Dank dem HPD tragen unsere Produkte dazu bei, LEED®- und WELL™-Anerkennungen zu erhalten.



Die von Industrie Ceramiche Piemme hergestellten Fliesen sind chemisch-physikalisch inert und geben während ihrer gesamten Nutzungsdauer von der Verlegung bis zur eventuellen Entsorgung keine flüchtigen organischen Verbindungen (VOC, Volatile Organic Compounds) in die Atmosphäre ab. Die Piemme-Materialien erfüllen daher die Richtlinien hinsichtlich der VOC und tragen zum Erhalt der vom LEED-Standard (Leadership in Energy and Environmental Design) vorgesehenen Punkte bei.



Zahlreiche Serien von Industrie Ceramiche Piemme sind nach UPEC zertifiziert, der französischen Qualitätsklassifizierung, die auf Grundlage der durch die europäische Norm EN 14411 und die Prüfberichte des CSTB ausgestellt wird. Jeder Artikel wird klassifiziert, und damit seine Eignung für die Verlegung in den verschiedenen Anwendungsbereichen bescheinigt.



CCC (China Compulsory Certificate) ist ein für viele am chinesischen Markt verkaufte Produkte vorgeschriebenes Sicherheitsprüfzeichen.



SASO QUALITY MARK
 Ein vorgeschriebenes Gütesiegel für den Export nach Saudi-Arabien. Die vom saudi-arabischen Normungsinstitut (Saudi Arabian Standards Organization - SASO) genehmigte Marke bezeichnet die Übereinstimmung des Produkts mit Vorschriften Saudi-Arabiens. Die Produkte von Industrie Ceramiche Piemme S.p.A. entsprechen den von der internationalen Norm SASO ISO 13006:2018 (Keramische Fliesen und Platten - Definitionen, Klassifizierung, Eigenschaften und Kennzeichnung) vorgesehenen Standards und Anforderungen.



Thai Industrial Standards Institute ist ein obligatorisches Zertifikat für den Warenexport nach Thailand. Dieses Zeugnis garantiert die Produktanforderungen gemäß den thailändischen Standards.

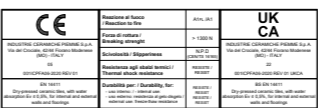

Die von Industrie Ceramiche Piemme S.p.A. produzierten Artikel entsprechen der Verordnung Nr. 305/2011, welche die Modalitäten definiert, mit denen Baustoffhersteller die Leistungen der in den Handel gebrachten Produkte angeben müssen. Es handelt sich um eine Konformitätserklärung zum Schutz der Verbrauchersicherheit, ohne die das Produkt innerhalb der Europäischen Union nicht in Umlauf gebracht werden darf. Das Gütezeichen CE auf der Verpackung garantiert, dass Industrie Ceramiche Piemme die geltenden europäischen Bestimmungen für das Inverkehrbringen der Baumaterialien erfüllt hat.

Liste der geprüften serie und klassifizierungen auf anfrage erhältlich.
 Technische karten der bescheinigten serie auf der website verfügbar: www.ceramichepiemme.it

Condizioni Generali di Vendita



General Conditions Of Sale



ART. 1 - NORMATIVA CONTRATTUALE

Le presenti condizioni generali, salvo eventuali modifiche o deroghe pattuite per iscritto, regolano tutti gli ordini dell'Acquirente (di seguito "Acquirente") relativi ai prodotti (di seguito "Prodotti") di INDUSTRIE CERAMICHE PIEMME S.P.A. (di seguito "PIEMME").

PIEMME non sarà vincolata da condizioni generali di acquisto dell'Acquirente, neanche nell'ipotesi in cui si faccia a loro riferimento o siano contenute negli ordini o in qualsiasi altra documentazione proveniente dall'Acquirente stesso, salvo il preventivo consenso scritto di PIEMME, ferma restando, in ogni caso, l'applicazione anche delle presenti condizioni generali.

In caso di contratto tra le presenti condizioni generali e quelle dell'Acquirente, laddove ne sia stata concordata per iscritto l'applicazione come da precedente paragrafo, troveranno applicazione le presenti condizioni generali.

Le presenti condizioni generali potranno essere integrate o modificate da specifici accordi scritti delle Parti, restando inteso che l'efficacia di tali integrazioni o modifiche sarà limitata allo specifico ordine o contratto.

ART. 2 - ORDINI

Gli ordini comunque pervenuti a PIEMME sono per quest'ultima impegnativi solo dopo la loro eventuale approvazione scritta, restando in ogni caso insindacabile facoltà di PIEMME accettarli o recedere - senza oneri - dagli stessi prima della consegna dei Prodotti. Eventuale conferma d'ordine di PIEMME che sia, anche parzialmente, difforme dall'ordine, sarà vincolante per l'Acquirente che non ne abbia contestato la difformità con lettera raccomandata A/R o PEC, entro 5 giorni dal suo ricevimento.

Nel caso che l'ordine sia confermato solo verbalmente, con l'inizio delle consegne dei Prodotti si intendono accettate dall'Acquirente, senza riserve, tutte le condizioni riportate nelle presenti condizioni generali.

Si conviene inoltre che, se dopo la conferma dell'ordine, PIEMME venga a conoscenza che le condizioni patrimoniali dell'Acquirente siano divenute tali da porre in pericolo l'adempimento dell'obbligazione di pagamento del prezzo dei Prodotti (in via esemplificativa, se l'Acquirente abbia subito protesti, sequestri, pignoramenti o altri atti pregiudizievoli a carico dell'acquirente), oppure l'Acquirente versi nelle condizioni di cui all'art. 1186 c.c., quest'ultima potrà sospendere l'ordine ed esigere particolari garanzie oppure esercitare il recesso dal contratto mediante comunicazione scritta con raccomandata A/R o PEC, salvo in ogni caso, il diritto al risarcimento dell'eventuale danno. L'Acquirente si impegna a comunicare per iscritto a PIEMME, con congruo anticipo, comunque non inferiore a 48 ore rispetto alla data prevista per il ritiro, l'eventuale variazione del luogo di destinazione dei Prodotti, se diverso da quella citata nella conferma d'ordine. In mancanza di tale comunicazione, la destinazione originariamente indicata si intende confermata.

ART. 3 - CAMPIONI E MATERIALI PROMOZIONALI

I dati figuranti nei documenti illustrativi di PIEMME, così come le caratteristiche dei campioni e dei modelli inviati, hanno carattere di indicazioni approssimative. Questi dati non hanno valore impegnativo se non espressamente concordato per iscritto.

ART. 4 - CONSEGNA

Salvo diversa pattuizione per iscritto, la consegna dei Prodotti si intende sempre Ex Works (franco magazzino venditore) nel rispetto degli Incoterms vigenti alla data della consegna ed avvenuta a carico completamente presso i magazzini in Italia di PIEMME. Ogni rischio del trasporto, compresi ammannchi, rotture, deterioramenti e manomissioni, è a carico dell'Acquirente anche se il prezzo dei Prodotti sia stato pattuito fuori di porto, FOB o C&F. Eventuali accordi con spedizionieri si intendono sempre conclusi in nome e per conto dell'Acquirente, in forza di mandato ai sensi dell'art. 1703 e ss. c.c., che fin d'ora ratifica ed accetta l'operato di PIEMME.

I termini di consegna hanno carattere indicativo: eventuali ritardi nelle consegne, interruzioni, sospensioni totali o parziali delle vendite non daranno diritto ad indennizzi o risarcimento danni. L'Acquirente si impegna a ritirare i Prodotti o ad accettarne la consegna non appena gliene sia comunicato l'approntamento, e comunque non oltre 60 giorni dalla data di comunicazione di merce pronta. In caso di mancato ritiro entro il suddetto periodo, l'ordine si considererà annullato, fatto salvo il diritto di PIEMME di trattenere la somma già riscossa a titolo di penale, restando salvo, in ogni caso, il risarcimento del danno. È espressamente esclusa qualsiasi garanzia, responsabilità o rischio a carico di PIEMME in relazione ai Prodotti in sosta per il citato periodo.

La mancata contestazione, al momento del ritiro, di ammannchi ovvero di rotture, difformità o vizi negli imballaggi dei Prodotti preclude all'Acquirente eventuali successive contestazioni in tal senso.

Qualora la regola Incoterms concordata tra le parti preveda che l'Acquirente debba curare il trasporto dei Prodotti fuori dall'Italia:

a) in caso di cessione intra-comunitaria, l'Acquirente, entro 45 giorni dalla ricezione dei Prodotti presso il suo magazzino, dovrà trasmettere a PIEMME un originale o una copia del documento di trasporto internazionale CMR o di altro documento di trasporto, sottoscritti a destinazione dall'Acquirente ovvero, in assenza del CMR, una dichiarazione di ricezione delle merci;

b) in caso di cessione extra-comunitaria, l'Acquirente si impegna a:

i) presentare la dichiarazione doganale di esportazione (DAU-EX e DAE) ed effettuare l'appuramento del MRN (Movement Reference Number) presso la dogana del territorio comunitario di uscita dei Prodotti, entro 90 giorni dalla data di consegna in Italia dei Prodotti stessi;

ii) inviare a PIEMME, entro 90 giorni dalla data di consegna, i documenti comprovanti l'esportazione dei Prodotti (dichiarazione di esportazione DAU-EX, DAE e notifica di avvenuta esportazione);

iii) confermare prontamente per iscritto a PIEMME l'avvenuta esecuzione delle suddette formalità e fornire ogni ulteriore documento comprovante l'esecuzione delle suddette formalità e l'uscita dei Prodotti dal territorio dell'Unione Europea. In caso di inadempienza dell'Acquirente a quanto sopra pattuito, PIEMME avrà il diritto di addebitare immediatamente all'Acquirente l'Imposta sul Valore Aggiunto relativa

alla fornitura e connessa alla mancata prova del trasporto dei Prodotti in altro Stato Membro della Comunità Europea o mancato appuramento della esportazione. In ogni caso, l'Acquirente errà indenne e manlevata PIEMME in relazione al pagamento di tutto quanto eventualmente dovuto dalla stessa PIEMME nei confronti dell'Amministrazione Finanziaria, a titolo di sanzioni ed interessi e ad altro titolo, in connessione con la fornitura e la mancata prova del trasporto dei Prodotti in altro Stato Membro della Comunità Europea o al mancato appuramento della esportazione.

ART. 5 - CONTESTAZIONI

La garanzia dei Prodotti è limitata al solo materiale ceramico di prima scelta, con una tolleranza del 5%; ogni garanzia rimane esclusa espressamente per tutti i Prodotti di scelta secondaria, sottoselela e di stock. Le contestazioni per vizi non occulti hanno efficacia solo quando sono formulate per iscritto prima della posa in opera dei Prodotti. Le differenze di tonalità non costituiscono vizio comportante la garanzia di cui all'art. 1490 e seguenti c.c.. Le tonalità di colore dei campioni e delle riproduzioni sono da ritenersi puramente indicative e non strettamente vincolanti la fornitura. Eventuali contestazioni di vizi o difformità dei Prodotti dovranno pervenire a PIEMME per iscritto a mezzo raccomandata A/Ro PEC, indirizzata direttamente al ns. "Ufficio Logistica, Qualità e Servizio Post-Vendita", nei termini di cui all'art. 1495 c.c.

L'Acquirente s'impegna a tenere a disposizione le partite contestate così da consentire il controllo dei vizi o difformità denunciati. In ogni caso, si ribadisce che la posa in opera del materiale ne comporta l'accettazione ed esonera PIEMME da qualsiasi responsabilità. Per nessuna ragione l'Acquirente potrà restituire i Prodotti senza espressa preventiva autorizzazione scritta di PIEMME. Eventuali vizi o difformità dei Prodotti, ove siano denunciati nei termini di legge ed accertati o riconosciuti da PIEMME, danno diritto unicamente alla sostituzione dei Prodotti a condizione di preventivo accordo scritto e della preventiva restituzione a PIEMME di quelli viziati o difformi, con conseguente rinuncia a qualsivoglia ulteriore azione, pretesa, istanza o rimedio, anche di natura risarcitoria. PIEMME non si assume nessuna responsabilità sulla idoneità dei Prodotti all'uso cui l'Acquirente lo intende destinare, e ciò neppure nell'ipotesi che, da parte di PIEMME, vengano forniti suggerimenti o indicazioni circa l'installazione e l'impiego dello stesso, da intendersi in ogni caso non vincolanti per l'Acquirente.

Qualora la contestazione risulti infondata, l'Acquirente sarà tenuto a risarcire a PIEMME tutte le spese dalla stessa sostenute per l'accertamento e la gestione stragiudiziale della contestazione (viaggi, perizie, ecc.); uguale obbligo avrà l'Acquirente se il reclamo risulti solo parzialmente fondato.

ART. 6 - PREZZI

I prezzi indicati sui listini di PIEMME devono intendersi Ex Works (franco magazzino venditore), al netto di IVA e di sconti. Tali prezzi non includono, tra gli altri, i costi di spedizione, di trasporto, di eventuale assicurazione, né di eventuali ulteriori oneri (tasse, imposte, ecc.). Il prezzo dei Prodotti sarà quello previsto nel listino tempo per tempo vigente al momento della conferma d'ordine o, qualora i Prodotti non siano inseriti nel listino prezzi, il prezzo degli stessi sarà quello indicato nell'ordine. Anche dopo la conferma d'ordine e fino al momento della consegna delle merci, sarà facoltà di PIEMME disporre variazioni del prezzo per sopravvenuti aumenti dei costi di materie prime, mano d'opera, energia e altre spese di produzione. In tal caso l'Acquirente potrà recedere dal contratto mediante comunicazione scritta, da inviare con raccomandata A/R o PEC, entro 30 giorni dal ricevimento della comunicazione di PIEMME di variazione del prezzi dei Prodotti.

ART. 7 - PAGAMENTO

Il pagamento dovrà essere effettuato, salvo diverso accordo scritto, presso la sede di PIEMME o presso istituto bancario dalla stessa indicato. Eventuali pagamenti fatti ad agenti, rappresentanti o ausiliari di commercio di PIEMME, se previamente autorizzati per iscritto da PIEMME, avranno effetto liberatorio per l'Acquirente. Qualsiasi ritardo o irregolarità nel pagamento dei Prodotti legitimerà PIEMME a sospendere le forniture o risolvere i contratti in corso, anche se non relativi ai pagamenti in questione, fatto salvo, in ogni caso, il diritto al risarcimento degli eventuali danni. Il ritardo nei pagamenti dovuti dall'Acquirente comporta, senza necessità di messa in mora, l'applicazione degli interessi moratori nella misura del tasso previsto dal D. Lgs. 231/2002 all'integrale rifusione delle spese legali e di assistenza, sia stragiudiziale che giudiziale.

In nessun caso l'Acquirente potrà ritardare o sospendere il pagamento, indipendentemente da qualsiasi rivendicazione e/o reclamo esposto.

Nessuna contestazione di vizi o difformità, nonché ogni altra controversia in essere tra PIEMME e l'Acquirente in ordine all'esecuzione dei contratti vendita dei Prodotti sarà efficace e potrà essere presa in considerazione, e così pure nessuna azione potrà essere iniziata se non dopo l'avvenuto integrale pagamento del prezzo (clausola solve et repte).

ART. 8 - RISERVATO DOMINIO

La vendita dei Prodotti viene effettuata con la clausola del riservato dominio; pertanto, nel caso in cui il pagamento, per accordi contrattuali, debba essere effettuato, in tutto o in parte dopo la consegna, i Prodotti consegnati restano di proprietà di PIEMME fino all'integrale pagamento del prezzo.

ART. 9 - CAUSE DI FORZA MAGGIORE ED ECCESSIVA ONEROSITÀ

PIEMME può, senza oneri, penalità e responsabilità di alcun genere e natura, nemmeno risarcitoria, sospendere, in tutto o in parte, l'esecuzione del contratto, o recedere, in tutto o in pare dallo stesso, qualora l'adempimento risulti oggettivamente impossibile o eccessivamente oneroso, a causa di eventi di forza maggiore (senza pretesa di completezza, scioperi, incidenti, esplosioni, incendi, guerre, eventi naturali, epidemie, divieti legali, assenze, ritardi o difficoltà di approvvigionamento di materie prime, guasti e/o cause simili ecc.).

ART. 10 - CESSIONE DEL CONTRATTO

L'Acquirente non può cedere il contratto, od in singoli rapporti obbligatori da questo

derivanti, senza l'accettazione scritta di PIEMME; anche in tal caso l'Acquirente rimane comunque solidalmente responsabile con il cessionario per le obbligazioni cedute.

ART. 11 - INTERPRETAZIONE, MODIFICHE, CLAUSOLE INVALIDE

Per l'interpretazione delle presenti condizioni generali fa fede unicamente il testo italiano delle stesse. Eventuali allegati o premesse si intendono parte integrante dei contratti cui si riferiscono.

Ogni richiamo ai listini prezzi, condizioni generali od altro materiale di PIEMME si intende riferito ai documenti in vigore al momento del richiamo stesso, salvo non sia diversamente specificato; devono ritenersi annullati i testi corrispondenti in precedenza in vigore tra le parti.

Le dichiarazioni effettuate od il comportamento tenuto dalle parti durante le trattative o nel corso dell'esecuzione del contratto possono contribuire all'interpretazione del solo contratto cui si riferiscono e nei limiti in cui non contrastano con le presenti condizioni generali o con gli accordi scritti presi dalle parti in occasione della conclusione del contratto in questione.

Salvo quanto sopra previsto all'art. 2), ogni modifica od integrazione fatta dalle parti ai contratti cui si applicano le presenti condizioni generali dovrà essere effettuata per iscritto, a pena di nullità. La deroga ad una o più disposizioni delle presenti condizioni generali non deve interpretarsi estensivamente o per analogia e non implica la volontà di disapplicare le condizioni generali nel loro insieme.

Eventuali variazioni delle condizioni contrattuali concordate tra le parti non costituiscono novazione del contratto, salvo espresa indicazione contraria, fatta per iscritto. In caso di disposizioni contrattuali invalide od inefficaci, il contratto nella sua globalità va integrato per conseguire, in modo conforme alla legge, lo scopo essenziale perseguito dall'accordo contenente le clausole in questione.

L'eventuale tolleranza di comportamenti posti in essere in violazione delle disposizioni contenute nelle presenti condizioni generali non costituisce rinuncia ai diritti derivanti dalle disposizioni violate né al diritto di esigere l'esatto adempimento di tutti i termini e di tutte le condizioni qui previste.

ART. 12 – FORO COMPETENTE

Il presente contratto è regolato dalla legge, anche processuale, italiana. Per ogni controversia relativa o comunque collegata ai contratti cui si applicano le presenti condizioni generali la giurisdizione è attribuita al Giudice italiano. Per ogni controversia nascente dall'interpretazione ed esecuzione delle presenti condizioni generali è competente il foro di Reggio Emilia.

ART. 13 - PROPRIETÀ INDUSTRIALE E DISTRIBUZIONE SELETTIVA – LIMITI ALLA RIVENDITA

La sottoscrizione delle presenti condizioni generali non conferisce, in alcun modo, all'Acquirente il diritto di utilizzare in nessuna forma i marchi di PIEMME e/o altri segni distintivi della stessa; il loro eventuale uso dovrà essere preventivamente autorizzato da PIEMME ed espressamente disciplinato con separata scrittura. Le forniture dei Prodotti di PIEMME sono destinate all'installazione presso l'utente finale e non è consentita altra forma di rivendita a ulteriori intermediari commerciali diversi dagli utenti finali, salvo previa autorizzazione scritta di PIEMME e salvo che l'acquisto dei Prodotti avvenga presso punti vendita a ciò espressamente autorizzati da Piemme. La rivendita di Prodotti in violazione di tale divieto deve considerarsi pertanto non consentita ed equiparata ad uso illecito dei diritti di proprietà industriale e intelletuale di PIEMME, con diritto della stessa PIEMME di chiederne il sequestro presso qualunque detentore. Resta inteso che PIEMME si riserva il diritto di procedere giurisdizionalmente nei confronti di chiunque sia coinvolto in rivendite non autorizzate.

ART. 14 - INFORMATIVA DI SINTESI

Ai sensi dell'art. 13 del Regolamento UE 2016/679, informiamo che i Vostri dati sono inseriti in banche dati sia elettroniche che cartacee e sono trattati dalle persone autorizzate, esclusivamente per finalità amministrative e contabili. I dati potranno essere comunicati a terzi per dar corso ai rapporti in essere o per obblighi di legge, ma non saranno diffusi. Informiamo inoltre che in qualsiasi momento potrà essere richiesto l'accesso ai dati e sarà possibile opporsi a taluni loro utilizzi, rivolgendosi allo scrivente Titolare.

Nota:

La presente informativa di sintesi è integrata da ulteriore informativa articolata ed estesa, disponibile senza alcun onere presso la sede sociale e/o visionabile sul sito internet aziendale:

http://www.ceramichepiemme.it, al seguente link "Informativa Privacy"

https://www.ceramichepiemme.it/informativa-privacy.

ART. 1 - CONTRACTUAL REGULATIONS

These general conditions, unless amended or waived in writing, shall govern all orders by the purchaser (hereinafter referred to as the "Purchaser") relating to the products (hereinafter referred to as the "Products") of INDUSTRIE CERAMICHE PIEMME S.P.A. (hereinafter referred to as "PIEMME").

PIEMME shall not be bound by general conditions of purchase of the Purchaser, not even where reference is made to them or they are contained in the orders or in any other documentation from the Purchaser, except with the prior written consent of PIEMME, without prejudice, in any case, to the application of these general conditions as well.

In the event of a conflict between these general conditions and those of the Purchaser, where their application has been agreed upon in writing in accordance with the preceding paragraph, these general conditions shall apply.

These general conditions may be supplemented or amended by specific written agreements of the Parties, it being understood that the effectiveness of such supplements or amendments shall be limited to the specific order or contract.

ART. 2 - ORDERS

Orders received by PIEMME shall be binding for the latter only after their approval in writing, PIEMME having, in any case, the unquestionable right to accept them or to withdraw – without charge – from them before delivery of the Products. Any order confirmation by PIEMME that even partially differs from the order shall be binding for the Purchaser who has not reported its non-conformity by registered letter with return receipt or certified email, within 5 days from its receipt.

In the event that the order is confirmed only verbally, with the commencement of delivery of the Products, all conditions set forth in these general conditions shall be deemed accepted by the Purchaser without reservation.

It is also agreed that, if, after order confirmation, PIEMME learns that the financial conditions of the Purchaser have become such as to jeopardize the fulfilment of the obligation to pay the price of the Products (by way of example, if the Purchaser has been subject to protests, seizures, attachments or other prejudicial acts against it), or the Purchaser is in the conditions set forth in Art. 1186 of the Italian Civil Code, PIEMME shall be entitled to suspend the order and demand special guarantees or to withdraw from the contract by means of written communication by registered letter with return receipt or certified email, without prejudice, in any case, to the right to compensation for any damage.

The Purchaser undertakes to communicate in writing to PIEMME, with suitable advance notice, in any case not less than 48 hours before the date scheduled for collection, any change in the place of destination of the Products, if different from the one mentioned in the order confirmation. Lacking such notification, the destination originally indicated is deemed to be confirmed.

ART. 3 - SAMPLES AND PROMOTIONAL MATERIALS

The data in PIEMME's illustrative documents, as well as the characteristics of the samples and models sent, are approximate indications. These data are not binding unless expressly agreed in writing.

ART. 4 - DELIVERY

Unless otherwise agreed upon in writing, the delivery of the Products shall always be deemed Ex Works (free to the seller's warehouse) in compliance with the Incoterms in force on the date of delivery, once completed to PIEMME's warehouses in Italy. All transport risks, including shortages, breakages, deterioration and tampering, shall be borne by the Purchaser even if the price of the Products has been agreed free at port, FOB or C&F. Any agreements with forwarding agents shall always be deemed concluded in the name and on behalf of the Purchaser, by virtue of a mandate pursuant to Art. 1703 et seq. of the Italian Civil Code. As of now, the Purchaser ratifies and accepts the actions of PIEMME.

The terms of delivery are indicative in nature: no delays in delivery, interruptions or total or partial suspensions of sales shall entitle the customer to compensation or damages. The Purchaser undertakes to collect the Products or to accept delivery of them as soon as he is notified that they are ready, and in any case no later than 60 days from the date of notification that the goods are ready.

In the event that the Products are not collected within the aforementioned period, the order shall be deemed cancelled, without prejudice to PIEMME's right to retain the amount already collected as a penalty, without prejudice, in any event, to compensation for damages. Any warranty, liability or risk of PIEMME in relation to the Products stored for the aforementioned period is expressly excluded.

Failure to notify the Purchaser at the time of collection of shortages or of breakages, defects or non-conformities in the packaging of the Products shall preclude the Purchaser from making any subsequent claims in this respect.

If the Incoterms rule agreed between the parties provides that the Purchaser must arrange for the transport of the Products outside of Italy:

a) for intra-EU transfers, within 45 days from receipt of the Products at its warehouse, the Purchaser shall transmit to PIEMME an original or a copy of the CMR international consignment note or other transport document, signed at the destination by the Purchaser or, lacking a CMR, a declaration of receipt of the goods;

b) for transfers outside the EU, the Purchaser undertakes to

i) present the customs export declaration (SAD-EX and Administrative Accompanying Document - AAD) and confirm the MRN (Movement Reference Number) at the customs offices of the EU territory of exit of the Products, within 90 days from the date of delivery of the Products to Italy;

ii) send to PIEMME, within 90 days from the date of delivery, the documents proving the export of the Products (SAD-EX export declaration, AAD and export notification);

iii) promptly confirm in writing to PIEMME the execution of the aforesaid formalities and provide any further document proving the execution of those formalities and the exit of the Products from the territory of the European Union.

In the event that the Purchaser fails to comply with the foregoing, PIEMME shall have the right to immediately charge the Purchaser the Value Added Tax related to the supply and connected to the failure to prove the transport of the Products to another Member State of the European Union or the failure to confirm the export. In any case, the Pur-

chaser shall indemnify and hold PIEMME harmless in relation to the payment of any amount that may be due by PIEMME to the Tax Authorities, by way of penalties and interests or under any other title, in connection with the supply and the failure to prove the transport of the Products to another Member State of the European Community or the failure to confirm the export.

ART. 5 - OBJECTIONS

Product warranties are limited to first grade ceramic material only, with a tolerance of 5%; all warranties are expressly excluded for all seconds, lower grade products and stock products. Complaints regarding non-concealed defects shall only be effective when they are made in writing prior to the installation of the Products. Differences in tone do not constitute a defect giving rise to application of the warranty under Art. 1490 et seq. of the Italian Civil Code. The colour tones of the samples and reproductions are to be considered purely indicative and not strictly binding on delivery. Any claims of defects or non-conformities of the Products must be received by PIEMME in writing by registered letter with return receipt or certified email, addressed directly to our "Ufficio Logistica, Qualità e Servizio Post-Vendita" (Logistics, Quality and After-Sales Service Department), within the terms set out in Art. 1495 of the Italian Civil Code.

The Purchaser undertakes to keep the disputed batches available so that the reported defects or non-conformities can be checked. In any case, it is reiterated that the installation of the material implies its acceptance and exempts PIEMME from any liability. Under no circumstances may the Purchaser return the Products without the express prior written authorisation of PIEMME. Any defects or non-conformities of the Products, if reported within the terms set out by law and ascertained or acknowledged by PIEMME, shall give right only to replacement of the Products, on condition of prior written agreement and of the preventive return to PIEMME of the defective or non-conforming Products, with consequent waiver of any further action, claim, request or remedy, also of a compensatory nature. PIEMME assumes no liability regarding the suitability of the Products for the use intended by the Purchaser, not even in the event that suggestions or indications as to the installation and use of the same are provided by PIEMME, which shall in any event not be considered binding for the Purchaser.

If the claim proves to be unfounded, the Purchaser shall be obliged to reimburse PIEMME for all expenses incurred by PIEMME for the investigation and the extra-judicial management of the claim (travel, appraisals, etc.); the Purchaser shall have the same obligation if the claim proves to be only partially grounded.

ART. 6 - PRICES

The prices shown on PIEMME's price lists are Ex Works (free to the seller's warehouse), excluding VAT and discounts. These prices do not include, inter alia, the costs of shipping, transportation, any insurance or any other charges (taxes, duties, etc.). The price of the Products shall be the price on the price list in force at the time of order confirmation or, if the Products are not included on the price list, their price shall be the price indicated in the order. Even after order confirmation, and up to the time of delivery of the goods, PIEMME shall have the right to order price changes due to increases in the costs of raw materials, labour, energy and other production costs. In such a case, the Purchaser may withdraw from the contract by written notice, to be sent by registered letter with return receipt or certified email, within 30 days from receipt of PIEMME's communication of changes in the price of the Products.

ART. 7 - PAYMENT

Payment shall be made, unless otherwise agreed in writing, to the registered office of PIEMME or to a bank indicated by PIEMME. Any payments made to agents, representatives or sales assistants of PIEMME, if previously authorised in writing by PIEMME, shall have the effect of releasing the Purchaser.

Any delay or irregularity in the payment for the Products shall entitle PIEMME to suspend supplies or terminate ongoing contracts, even if not related to the payments in question, without prejudice, in any case, to the right to compensation for any damages. Any delay in payments due by the Purchaser shall entail, without the necessity of a default notice, the application of default interest at the rate provided for by Italian Legislative Decree No. 231/2002 to the full reimbursement of legal and assistance expenses, both extrajudicial and judicial.

Under no circumstances may the Purchaser delay or suspend payment, irrespective of any claims and/or complaints asserted.

No complaints of defects or non-conformities, or any other dispute existing between PIEMME and the Purchaser concerning the performance of the contracts of sale of the Products shall be effective or may be taken into consideration, and likewise no action may be commenced until after full payment of the price (solve et repte clause).

ART. 8 - RETENTION OF TITLE

The sale of the Products is carried out with a retention of title clause; therefore, in the event that, due to contractual agreements, payment must be made in whole or in part after delivery, the Products delivered SHALL remain the property of PIEMME until full payment of the price.

ART. 9 – FORCE MAJEURE AND HARDSHIP

PIEMME may, without charges, penalties and liability of any kind and nature, not even of a compensatory nature, suspend, in whole or in part, the performance of the contract, or withdraw, in whole or in part, from the same, if the fulfilment is objectively impossible or excessively onerous, due to events of force majeure (merely by way of example, strikes, accidents, explosions, fires, wars, natural events, epidemics, legal prohibitions, lack of, delays or difficulties in the supply of raw materials, breakdowns and/or similar causes, etc.).

ART. 10 - ASSIGNMENT OF THE CONTRACT

The Purchaser may not assign the contract, or individual obligatory relationships deriving therefrom, without the written acceptance of PIEMME, even in such a case the Purchaser remains, in any event, jointly and severally liable with the assignee for the

assigned obligations.

ART. 11 - INTERPRETATION, AMENDMENTS, INVALID CLAUSES

These general conditions shall be interpreted only on the basis of the Italian text. Any annexes or recitals shall be deemed an integral part of the contracts to which they refer.

Any reference to price lists, general conditions or other material of PIEMME shall be deemed to refer to the documents in force at the time of the reference, unless otherwise specified; any corresponding texts previously in force between the parties shall be deemed null and void.

Statements made or conduct of the parties during negotiations or in the course of the performance of the contract may only contribute to the interpretation of the contract to which they refer and insofar as they do not conflict with these general conditions or with the written agreements made by the parties on concluding the contract in question. Except as provided for in Art. 2) above, any amendments or additions made by the parties to the contracts to which these general conditions apply shall be made in writing, on penalty of nullity. A concession regarding one or more provisions of these general conditions shall not be interpreted extensively or by analogy and shall not imply the intention to disapply the general conditions overall.

No changes in the contractual conditions agreed between the parties shall constitute novation of the contract unless expressly stated otherwise in writing. In the case of invalid or ineffective contractual provisions, the contract as a whole must be supplemented in order to achieve, in a manner consistent with the law, the essential purpose pursued by the agreement containing the clauses in question.

Tolerance of conduct in violation of the provisions contained in these general conditions shall not constitute a waiver of the rights arising from the violated provisions nor of the right to demand the exact fulfilment of all terms and conditions herein.

ART. 12 - LEGAL JURISDICTION

This contract is governed by Italian law, including procedural law. For any dispute relating to or in any way connected with the contracts to which these general conditions apply, jurisdiction shall be vested in the Italian courts. Any dispute arising from the interpretation and execution of these general conditions shall be settled by the Court of Reggio Emilia.

ART. 13 - INDUSTRIAL PROPERTY AND SELECTIVE DISTRIBUTION - LIMITS TO RE SALE

The undersigning of the present general conditions does not give the Purchaser the right to use in any form PIEMME's trade marks and/or other distinctive signs; their possible use shall be previously authorised by PIEMME and expressly regulated in a separate agreement.

The supplies of PIEMME's Products are intended for installation at the end user's premises and no other form of resale to commercial intermediaries other than end users is permitted, except with the prior written authorisation of PIEMME and unless the purchase of the Products takes place at points of sale expressly authorised by PIEMME for that purpose. The resale of Products in breach of that prohibition must therefore be considered as not allowed and equated to an unlawful use of PIEMME's industrial and intellectual property rights, with the right of PIEMME to request their seizure from any holder thereof. It is understood that PIEMME reserves the right to take legal action against anyone involved in unauthorised resale.

ART. 14 - SUMMARY DISCLOSURE

Pursuant to Art. 13 of EU Regulation 2016/679, we inform you that your data are stored in both electronic and hard copy databases and are processed by authorised persons exclusively for administrative and accounting purposes. The data may be communicated to third parties for the purpose of carrying out existing relations or for legal obligations, but will not be disseminated. We also inform you that you may at any time request access to the data and may object to certain uses of the data by contacting the undersigned Data Controller.

N.B.:

This summary disclosure is supplemented by further detailed, extended disclosure, which is available free of charge at the company's registered office and/or can be viewed on the company website: http://www.ceramiche-piemme.com, at the following link "Privacy" https://www.ceramiche-piemme.com/privacy.

Allgemeine Geschäftsbedingungen

ART. 1 – VERTRAGSBESTIMMUNGEN

Diese allgemeinen Geschäftsbedingungen gelten, sofern sie nicht schriftlich geändert oder aufgehoben werden, für alle Bestellungen des Käufers (nachstehend „Käufer“ genannt) in Bezug auf die Produkte (nachstehend „Produkte“ genannt) von INDUSTRIE CERAMICHE PIEMME S.P.A. (nachstehend „PIEMME“).

PIEMME ist nicht an die allgemeinen Einkaufsbedingungen des Käufers gebunden, auch dann nicht, wenn auf sie Bezug genommen wird oder sie in den Bestellungen oder anderen vom Käufer selbst stammenden Unterlagen enthalten sind, es sei denn, PIEMME hat vorher schriftlich zugestimmt, wobei in jedem Fall auch die vorliegenden allgemeinen Geschäftsbedingungen gelten.

Im Falle eines Widerspruchs zwischen diesen allgemeinen Geschäftsbedingungen und denjenigen des Käufers, deren Anwendung gemäß dem vorherigen Absatz schriftlich vereinbart wurde, gelten die vorliegenden allgemeinen Geschäftsbedingungen. Diese allgemeinen Geschäftsbedingungen können durch besondere schriftliche Vereinbarungen der Vertragspartnern ergänzt oder geändert werden, wobei die Wirksamkeit solcher Ergänzungen oder Änderungen auf die jeweilige Bestellung oder den Vertrag beschränkt ist.

ART. 1 – VERTRAGSBESTIMMUNGEN

Diese allgemeinen Geschäftsbedingungen gelten, sofern sie nicht schriftlich geändert oder aufgehoben werden, für alle Bestellungen des Käufers (nachstehend „Käufer“ genannt) in Bezug auf die Produkte (nachstehend „Produkte“ genannt) von INDUSTRIE CERAMICHE PIEMME S.P.A. (nachstehend „PIEMME“).

PIEMME ist nicht an die allgemeinen Einkaufsbedingungen des Käufers gebunden, auch dann nicht, wenn auf sie Bezug genommen wird oder sie in den Bestellungen oder anderen vom Käufer selbst stammenden Unterlagen enthalten sind, es sei denn, PIEMME hat vorher schriftlich zugestimmt, wobei in jedem Fall auch die vorliegenden allgemeinen Geschäftsbedingungen gelten.

ART. 2 – BESTELLUNGEN

Die bei PIEMME eingegangenen Bestellungen sind für PIEMME erst nach ihrer etwaigen schriftlichen Genehmigung verbindlich, wobei PIEMME in jedem Fall das unannehbare Recht hat, die Bestellungen anzunehmen oder – ohne Kosten – vor der Lieferung der Produkte davon zurückzutreten. Jede Auftragsbestätigung von PIEMME, die auch nur teilweise von der Bestellung abweichen sollte, ist für den Käufer verbindlich, wenn er die Nichtübereinstimmung nicht innerhalb von 5 Tagen nach Erhalt per Einschreiben mit Rückschein oder zertifizierter E-Mail (PEC) beanstandet hat.

Wird die Bestellung nur mündlich bestätigt, so gelten mit dem Beginn der Lieferung der Produkte alle in diesen allgemeinen Geschäftsbedingungen festgelegten Bedingungen als vom Käufer vorbehaltlos akzeptiert. Es wird außerdem Folgendes vereinbart: Wenn PIEMME nach der Auftragsbestätigung erfährt, dass die finanziellen Verhältnisse des Käufers die Erfüllung der Verpflichtung zur Zahlung des Produktpreises gefährden sollten (z.B. wenn der Käufer von Insolvenzen, Pfändungen, Beschlagnahmungen oder anderen nachteiligen Handlungen betroffen ist), oder wenn der Käufer sich in den in Art. 1186 des italienischen Zivilgesetzbuches genannten Verhältnissen befindet, hat PIEMME das Recht, die Bestellung aufzuheben und besondere Garantien zu verlangen oder durch eine schriftliche Mitteilung per Einschreiben mit Rückschein oder zertifizierter E-Mail (PEC) vom Vertrag zurückzutreten, wobei in jedem Fall davon das Recht auf Schadenersatz unberührt bleibt.

Der Käufer verpflichtet sich, PIEMME mit angemessener Vorfrist, in jedem Fall aber mindestens 48 Stunden vor dem für die Abholung vorgesehenen Termin, schriftlich jede Änderung des Bestimmungsortes der Produkte mitzuteilen, falls dieser von dem in der Auftragsbestätigung genannten abweicht. Erfolgt keine solche Mitteilung, so gilt der ursprünglich angegebene Bestimmungsort als bestätigt.

ART. 3 – MUSTER UND WERBEMATERIALIEN

Die Daten in den erläuternden PIEMME Dokumenten sowie die Merkmale der zugesandten Muster und Modelle sind als ungefähre Angaben zu verstehen. Diese Daten sind nicht verbindlich, soweit dies nicht ausdrücklich in Schriftform vereinbart wurde.

ART. 4 – LIEFERUNG

Sofern nichts anderes schriftlich vereinbart wurde, erfolgt die Lieferung der Produkte immer ab Werk (ab Lager des Verkäufers) gemäß den am Tag der Lieferung geltenden Incoterms und nach Fertigstellung der Ladung in den Lagern von PIEMME in Italien. Alle Transportrisiken, einschließlich Fehlgängen, Brüche, Beschädigungen und Manipulationen, gehen zu Lasten des Käufers, auch wenn der Preis der Produkte portofrei, FOB oder C&F vereinbart wurde. Alle Vereinbarungen mit Speditionen gelten immer als im Namen und auf Rechnung des Käufers abgeschlossen, u.z. aufgrund einer Vollmacht gemäß Art. 1703 ff. des italienischen Zivilgesetzbuches, der ab sofort die Handlungen von PIEMME ratifiziert und akzeptiert. Die Lieferfristen sind unverbindlich; Lieferverzögerungen, Unterbrechungen, vollständige oder teilweise Aussetzung des Verkaufs geben dem Kunden keinen Anspruch auf Vergütungen oder Schadenersatz. Der Käufer verpflichtet sich, die Produkte abzuholen oder deren Lieferung anzunehmen, sobald ihm ihre Bereitstellung mitgeteilt wird, spätestens jedoch 60 Tage nach dem Datum der Bereitstellungsmitteilung. Wird die Bestellung nicht innerhalb der genannten Frist abgeholt, gilt sie als storniert, unbeschadet des Rechts von PIEMME, den bereits eingezogenen Betrag als Vertragsstrafe einzubehalten, in jedem Fall aber unter Vorbehalt des Schadenersatzes. Jegliche Garantie, Haftung oder Risiko seitens PIEMME in Bezug auf die für den oben genannten Zeitraum gepackten Produkte wird ausdrücklich ausgeschlossen. Versäumt der Käufer bei der Abholung die Beanstandung etwaiger Fehlgängen, Schäden, Verformungen oder Mängel an der Verpackung, so kann er keine diesbezüglichen Ansprüche mehr geltend machen. Falls die zwischen den Parteien vereinbarte Incoterms-Regel vorsieht, dass der Käufer für den Transport der Produkte außerhalb Italiens zuständig ist:

a) Im Falle einer innergemeinschaftlichen Veräußerung muss der Käufer PIEMME innerhalb von 45 Tagen nach Ein gang der Produkte in seinem Lager das Original oder eine Kopie des internationalen Beförderungs papiers CMR oder eines anderen, vom Käufer am Bestimmungsort unterzeichneten Transportdokuments oder, in Ermangelung eines CMR, eine Erklärung über den Erhalt der Ware übermitteln;
b) im Falle einer außergemeinschaftlichen Veräußerung verpflichtet sich der Käufer:
i) die Ausfuhranmeldung (Einheitspapier SAD-EX und Administrative Accompanying Document – AAD) vorzulegen und die MRN (Movement Reference Number) beim Zollamt des Gemeinschaftsgebiets, aus dem die Produkte ausgeführt werden, innerhalb von 90 Tagen ab dem Lieferdatum der Produkte in Italien nachzuweisen;
ii) PIEMME innerhalb von 90 Tagen ab dem Datum der Lieferung die Unterlagen zum Nachweis der Ausfuhr der Produkte (SAD-EX-Ausfuhranmeldung, AAD und Nachweis der erfolgten Ausfuhr) zu übermitteln;
iii) PIEMME unverzüglich schriftliche die Erfüllung der vorgenannten Formalitäten zu bestätigen und alle weiteren Dokumente vorzulegen, die die Erfüllung der vorgenannten Formalitäten und den Ausgang der Produkte aus dem Gebiet der Europäischen Union belegen.

Kommt der Käufer den vorgenannten Vereinbarungen nicht nach, hat PIEMME das Recht, dem Käufer sofort die Mehrwertsteuer in Rechnung zu stellen, die mit der Lieferung verbunden ist und die sich auf den fehlenden Nachweis des Transports der Produkte in einen anderen Mitgliedstaat der Europäischen Gemeinschaft oder den fehlenden Nachweis der Ausfuhr bezieht. In jedem Fall hält der Käufer PIEMME schad- und klaglos in Bezug auf die Zahlung jeglicher Beträge, die PIEMME den Steuerbehörden in Form von Sanktionen und Zinsen oder in irgendeiner anderen Form im Zusammenhang mit der Lieferung und dem Nichtnachweis des Transports der Produkte in einen anderen Mitgliedstaat der Europäischen Gemeinschaft oder dem fehlenden Nachweis der Ausfuhr schulden sollte.

ART. 5 – BEANSTANDUNGEN

Die Produktgarantie beschränkt sich ausschließlich auf das keramische Material der ersten Wahl, u.z. mit einer Toleranz von 5 %; für alle Produkte der zweiten oder einer minderwertigeren Wahl oder für Lagerbestände wird ausdrücklich keine Garantie geleistet. Beanstandungen für offensichtliche Fehler sind nur wirksam, wenn sie schriftlich vor der Verlegung der Produkte erfolgen. Farbtonunterschiede stellen keinen Fehler dar, der eine Gewährleistung nach Art. 1490 ff. des italienischen Zivilgesetzbuches begründet. Die Farböne der Muster und der Reproduktionen gelten reichungswegen und sind für den Lieferumfang nicht fest verbindlich. Etwaige Reklamationen wegen Mängeln oder Nichtkonformität der Produkte müssen schriftlich per Einschreiben mit Rückschein oder mit zertifizierter E-Mail (PEC) bei PIEMME eingehen und direkt an unsere Abteilung „Ufficio Logistica, Qualità e Servizio Post-Vendita“ („Logistik, Qualität und Kundendienst“) gerichtet werden, und zwar innerhalb der in Art. 1495 des italienischen Zivilgesetzbuches festgelegten Fristen.

Der Käufer verpflichtet sich, die beanstandeten Lose zur Verfügung zu halten, um die Kontrolle der gemeldeten Mängel oder Nichtkonformitäten zu ermöglichen. In jedem Fall wird darauf hingewiesen, dass die Installation des Materials dessen Annahme voraussetzt und PIEMME von jeder Haftung befreit. Der Käufer darf die Produkte unter keinen Umständen ohne die ausdrückliche vorherige schriftliche Genehmigung von PIEMME zurücksenden. Eventuelle Mängel oder Nichtkonformitäten der Produkte, die innerhalb der gesetzlich vorgesehenen Fristen gemeldet und von PIEMME festgestellt oder anerkannt werden, berechtigen PIEMME nur auf der Grundlage einer vorherigen schriftlichen Vereinbarung und der vorherigen Rücksendung der mangelhaften oder nicht konformen Produkte an PIEMME zum Ersatz der Produkte, unter Verzicht auf jegliche weitere Aktion, Forderung, Auforderung oder jegliches Rechtsmittel, auch zum Zweck des Schadenersatzes. PIEMME haftet nicht für die Eignung der Produkte für den vom Käufer beabsichtigten Verwendungszweck, auch nicht für den Fall, dass PIEMME Empfehlungen oder Hinweise zur Installation und Verwendung der Produkte erteilen sollte, die in jedem Fall für den Käufer als nicht verbindlich gelten.

Erweist sich die Beansandung als unberechtigt, ist der Käufer verpflichtet, PIEMME alle Kosten zu ersetzen, die PIEMME für die Untersuchung und die außergerichtliche Bearbeitung der Reklamation entstanden sind (Reisen, Garachten usw.); die gleiche Verpflichtung trifft den Käufer, wenn die Reklamation nur teilweise begründet ist.

ART. 6 – PREISE

Die in den Preislisten von PIEMME angegebenen Preise verstehen sich ab Werk (ab Lager des Verkäufers), ohne Mehrwertsteuer und Rabatte. Diese Preise enthalten unter anderem nicht die Kosten für Versand, Transport, eventuelle Versicherungen oder sonstige Abgaben (Steuern, Gebühren usw.). Der Preis der Produkte wird der jeweils am Zeitpunkt der Auftragsbestätigung gültige Listenpreis sein, oder der in der Bestellung angegebene Preis, falls die Produkte nicht in der Preisliste enthalten sind. PIEMME ist auch nach der Auftragsbestätigung bis zur Lieferung der Ware berechtigt, Preisänderungen aufgrund von Erhöhungen der Rohstoff-, Lohn-, Energie- und sonstigen Produktionskosten anzuordnen. In einem solchen Fall kann der Käufer innerhalb von 30 Tagen nach Erhalt der Mitteilung von PIEMME über die Preisänderung der Produkte durch schriftliche Mitteilung per Einschreiben mit Rückschein oder zertifizierter E-Mail (PEC) vom Vertrag zurücktreten.

ART. 7 – ZAHLUNG

Sofern keine anderslautende schriftliche Vereinbarung vorliegt, muss die Zahlung an den Sitz von PIEMME oder an eine von PIEMME angelegte Bank erfolgen. Etwaige Zahlungen an Händler, Vertreter oder Vertriebspersonal von PIEMME haben, sofern sie zuvor von PIEMME schriftlich genehmigt wurden, sind für den Käufer schuldfreiend. Jede Verspätung oder Unregelmäßigkeit bei der Zahlung berechtigt PIEMME, die Lieferungen einzustellen oder die laufenden Verträge aufzulösen, auch wenn sich diese nicht auf die betroffenen Zahlungen beziehen, unbeschadet des Rechts auf Schadenersatz. Bei Zahlungsvorzug des Käufers werden, ohne dass eine Inverzugesetzung erforderlich ist, Verzugszinsen in Höhe des vom ital. gesetzestretretenden Dekrets Nr. 231/2002 vorgesehenen Zinssatzes auf die vollständige Rücksertattung der Anwaltskosten und der sowohl außergerichtlichen wie auch gerichtlichen Betreuungskosten in Rechnung gestellt. Der Käufer darf die Zahlung in keinem Fall verspäten oder einstellen, ganz unabhängig von jeder Forderung und/oder jeder geltend gemachten Reklamation.

Die Beanstandung von Mängeln oder Nichtkonformitäten sowie alle anderen zwischen PIEMME und dem Käufer bestehenden Streitigkeiten im Zusammenhang mit der Erfüllung der Kaufverträge über die Produkte sind unwirksam und können nicht berücksichtigt werden, ebenso wenig wie die Einleitung eines Verfahrens vor der vollständigen Zahlung des Preises (Klausel „solve et repete“).

ART. 8 – EIGENTUMSVORBEHALT

Der Verkauf der Produkte erfolgt mit der Klausel des Eigentumsvorbehalts; daher bleiben die gelieferten Produkte bis zur vollständigen Bezahlung des Preises Eigentum von PIEMME, falls die Zahlung aufgrund vertraglicher Vereinbarungen ganz oder teilweise nach der Lieferung erfolgen muss.

ART. 9 – GRÜNDE HÖHERER GEWALT UND ÜBERMÄSSIGER HÄRTE

PIEMME kann ohne Kosten, Strafen und Haftung jeglicher Art, auch ohne Entschädi-

gung, die Erfüllung des Vertrags ganz oder teilweise einstellen oder ganz oder teilweise davon zurücktreten, falls die Erfüllung aufgrund von Ereignissen höherer Gewalt (ohne Anspruch auf Vollständigkeit, Streiks, Unfälle, Explosionen, Brände, Kriege, Naturereignisse, Epidemien, gesetzliche Verbote, Mangel, Verspätungen oder Schwierigkeiten bei der Versorgung mit Rohstoffen, Betriebsstörungen und/oder ähnliche Ursachen usw.) objektiv unmöglich oder mit übermäßiger Härte verbunden ist.

ART. 10 – VERTRAGSABTRETUNG

Der Käufer darf den Vertrag oder einzelne sich daraus ergebende Verpflichtungsverhältnisse nicht ohne schriftliche Zustimmung von PIEMME abtreten; auch in diesem Fall haftet der Käufer jedoch gesamtschuldnerisch mit dem Abtretungsempfänger für die abgetretenen Verpflichtungen.

ART. 11 – AUSLEGUNG, ÄNDERUNGEN, UNGÜLTIGE KLAUSELN

Für die Auslegung der vorliegenden allgemeinen Geschäftsbedingungen ist ausschließlich der italienische Text dieser allgemeinen Geschäftsbedingungen maßgebend. Etwaige Anhänge oder Präambeln gelten als wesentlicher Bestandteil der Verträge, auf die sie sich beziehen.

Jeder Verweis auf Preislisten, allgemeine Geschäftsbedingungen oder sonstiges Material von PIEMME gilt als Bezugnahme auf die zum Zeitpunkt des Verweises geltenden Dokumente, sofern nichts anderes angegeben ist; entsprechende Texte, die zuvor zwischen den Parteien in Kraft waren, gelten als nichtig.

Die von den Vertragspartnern während der Verhandlungen oder im Laufe der Vertragsausführung abgegebenen Erklärungen oder Verhalte n können nur zur Auslegung des Vertrags beitragen, auf die sie sich beziehen und nur soweit sie nicht mit den vorliegenden allgemeinen Geschäftsbedingungen oder den schriftlichen Vereinbarungen zwischen den Vertragspartnern bei der Schließung des betroffenen Vertrages im Widerspruch stehen.

Vorbehaltlich der Bestimmungen unter Art. 2) sind alle Änderungen oder Ergänzungen der Verträge, auf die diese allgemeinen Geschäftsbedingungen Anwendung finden, bei sonstiger Nichtigkeit in Schriftform durchzuführen. Die Abweichung von einer oder mehreren Bestimmungen dieser allgemeinen Geschäftsbedingungen darf nicht darf nicht als ausdehnend oder nach Ähnlichkeit ausgelegt werden und zieht nicht den Willen nach sich, von der Anwendung der allgemeinen Bedingungen in ihrer Gesamtheit abzusehen.

Eventuelle Veränderungen der zwischen den Vertragspartnern vereinbarten Vertragsbedingungen stellen keine Vertragsneuerung dar, sofern nicht ausdrücklich schriftlich anders vereinbart. Im Falle von nicht gültigen oder unwirksamen Vertragsbestimmungen ist der Vertrag in seiner Gesamtheit zu ergänzen, um gesetzesgemäß den wesentlichen Zweck zu erreichen, der die betreffenden Klauseln enthält.

Die Duldung eines Verhaltens, das gegen die in diesen allgemeinen Geschäftsbedingungen enthaltenen Bestimmungen verstößt, bedeutet weder einen Verzicht auf die Rechte, die sich aus den verletzten Bestimmungen ergeben, noch auf das Recht, die genaue Erfüllung aller hierin enthaltenen Bestimmungen zu verlangen.

ART. 12 – GERICHTSSTAND

Der vorliegende Vertrag unterliegt dem italienischen Recht, auch in Prozessen. Für alle Streitigkeiten im Zusammenhang mit den Verträgen, für die diese allgemeinen Geschäftsbedingungen gelten, ist der italienische Richter zuständig.

Für alle Streitigkeiten, die sich aus der Auslegung und Anwendung der vorliegenden allgemeinen Geschäftsbedingungen ergeben, ist das Gericht von Reggio Emilia zuständig.

ART. 13 – GEWERBLICHES EIGENTUM UND BESCHRÄNKTER VERTRIEB – EINSCHRÄNKUNGEN FÜR DEN WEITERVERKAUF

Die Unterzeichnung der vorliegenden allgemeinen Geschäftsbedingungen gibt dem Käufer nicht das Recht, die Markenzeichen von PIEMME und/oder sonstige Kennzeichen derselben in irgendeiner Form zu verwenden; ihre eventuelle Verwendung muss zuvor von PIEMME genehmigt und ausdrücklich in einem gesonderten Schriftstück geregelt werden.

Die von PIEMME gelieferten Produkte sind für die Installation beim Endverbraucher bestimmt. Ein Weiterverkauf an andere gewerbliche Zwischenhändler als den Endverbraucher ist nur mit vorheriger schriftlicher Genehmigung von PIEMME zulässig, es sei denn, der Kauf der Produkte erfolgt bei ausdrücklich von PIEMME dafür zugelassenen Verkaufsstellen. Der Weiterverkauf von Produkten unter Verstoß gegen dieses Verbot ist somit als unzulässig und als unerlaubter Gebrauch der gewerblichen und geistigen Eigentumsrechte von PIEMME zu betrachten, wobei PIEMME selbst das Recht hat, die Beschlagnahme bei egal welchem Produktinhaber zu verlangen. Es versteht sich, dass PIEMME sich das Recht vorbehält, rechtliche Schritte gegen jeden einzuleiten, der am unerlaubten Weiterverkauf beteiligt ist.

ART. 14 – ZUSAMMENFASSENDE INFORMATIONEN

Gemäß Art. 13 der EU-Verordnung 2016/679 informieren wir Sie darüber, dass Ihre Daten sowohl in elektronischen als auch in Papierdatenbanken gespeichert und von befigenen Personen ausschließlich zu Verwaltungs- und Buchhaltungszwecken verarbeitet werden. Die Daten können zum Zweck der Durchführung bestehender Beziehungen oder zur Erfüllung gesetzlicher Verpflichtungen an Dritte weitergegeben werden, werden aber nicht verbreitet. Wir informieren Sie auch darüber, dass Sie jederzeit Zugang zu den Daten verlangen und bestimmten Verwendungen der Daten widersprechen können, indem Sie sich an den Verantwortlichen der Verarbeitung wenden.

Anmerkung: Diese zusammenfassenden Informationen werden durch weitere ausführliche Informationen ergänzt, die am Sitz des Unternehmens kostenlos erhältlich sind und/oder auf der Website des Unternehmens https://www.ceramichepiemme.de unter folgendem Link „Datenschutzerklärung“ https://www.ceramichepiemme.de/datenschutzerklärung eingesehen werden können.

Conditions générales de vente

ARTICLE 1 – RÉGLEMENTS CONTRACTUELS

Les présentes conditions générales, sauf modification ou dérogation par écrit, régissent toutes les commandes de l'acheteur (ci-après « l'acheteur ») concernant les produits (ci-après « Produits ») de l'entreprise INDUSTRIE CERAMICHE PIEMME S.P.A. (ci-après « PIEMME »).

PIEMME ne sera pas liée par des conditions générales d'achat de l'acheteur, même s'il y est fait référence ou si elles sont contenues dans les commandes ou dans toute autre documentation provenant de l'acheteur lui-même, sauf consentement écrit préalable de PIEMME, nonobstant, dans tous les cas, l'application également des présentes conditions générales. En cas de conflit entre les présentes conditions générales et celles de l'acheteur, lorsque leur application a été convenue par écrit conformément au paragraphe précédent, les présentes conditions générales s'appliquent. Les présentes conditions générales peuvent être intégrées ou modifiées par des accords spécifiques pris par les parties par écrit, étant entendu que l'efficacité de ces intégrations ou modifications sera limitée à la commande ou au contrat spécifique.

ARTICLE 2 – COMMANDES

En tout état de cause, les commandes reçues par PIEMME ne seront contraignantes pour cette dernière qu'après leur éventuelle approbation par écrit, PIEMME ayant en tout cas le droit incontestable de les accepter ou de s'en rétracter - sans frais - avant la livraison des Produits. Toute confirmation de commande par PIEMME qui serait, même partiellement, différente de la commande, engagera l'acheteur qui n'a pas contesté la non-conformité par lettre recommandée avec accusé de réception ou PEC, dans les 5 jours suivant sa réception.

Dans le cas où la commande n'est confirmée qu'oralement, avec le début de la livraison des Produits, toutes les conditions énoncées dans les présentes conditions générales sont réputées acceptées par l'acheteur sans réserve.

Il est également convenu que si, après la confirmation de la commande, PIEMME apprend que les conditions financières de l'acheteur sont devenues telles qu'elles compromettent l'exécution de l'obligation de payer le prix des Produits (à titre d'exemple, si l'acheteur a fait l'objet de protêts, de séquestres, de saisies ou d'autres actes préjudiciables), ou que l'acheteur se trouve dans les conditions prévues par l'article 1186 du Code civil italien, PIEMME aura le droit de suspendre la commande et d'exiger des garanties spéciales ou de résilier le contrat par communication écrite par lettre recommandée avec accusé de réception ou PEC, sans préjudice, en tout cas, du droit à la réparation de tout dommage.

ARTICLE 3 – ÉCHANTILLONS ET MATÉRIEL PROMOTIONNEL

Les données figurant dans les documents illustratifs de PIEMME, ainsi que les caractéristiques des échantillons et modèles envoyés, sont des indications approximatives. Ces données ne sont pas contraignantes, sauf accord exprs par écrit.

ARTICLE 4 – LIVRAISON

Sauf accord écrit contraire, la livraison des Produits sera toujours considérée comme Départ usine (départ entrepôt du vendeur) conformément aux Incoterms en vigueur à la date de livraison et chargement dans les entrepôts de PIEMME en Italie. Tous les risques de transport, y compris manques, ruptures, détériorations et altérations, sont à la charge de l'acheteur même si le prix des Produits a été convenu franco de port, FOB ou CFR. Les éventuels accords avec les transitaires sont toujours considérés comme conclus au nom et pour le compte de l'acheteur, en vertu d'un mandat aux termes de l'article 1703 et suivants du Code civil italien qui, dès à présent, ratifie et accepte les actions de PIEMME.

Les délais de livraison ont un caractère indicatif : les retards de livraison, les interruptions, les suspensions totales ou partielles des ventes ne donnent pas droit à une indemnisation ou à des dommages et intérêts. L'acheteur s'engage à retirer les Produits ou à en prendre livraison dès qu'il est informé qu'ils sont prêts, et en tout cas au plus tard dans les 60 jours à compter de la date de notification de marchandise prête.

Par défaut de retrait dans le délai susmentionné, la commande sera considérée comme annulée, sans préjudice du droit de PIEMME de conserver le montant déjà perçu à titre de pénalité, sous réserve, en tout état de cause, de dommages et intérêts. En ce qui concerne les Produits entreposés pendant la période susmentionnée, toute garantie, toute responsabilité ou tout risque à la charge de PIEMME sont expressément exclus. Le défaut de notification à l'acheteur, au moment du retrait, de manques, de ruptures, de non-conformités ou de défauts dans l'emballage des marchandises, empêche l'acheteur de faire toute réclamation ultérieure à cet égard.

Si la règle Incoterms convenue entre les parties prévoit que l'acheteur doit organiser le transport des Produits en dehors de l'Italie :
a) en cas de transfert intracommunautaire, l'acheteur, dans un délai de 45 jours à compter de la réception des Produits dans son entrepôt, devra transmettre à PIEMME un original ou une copie du document de transport international CMR ou autre document de transport, signé à destination par l'acheteur ou, en l'absence de CMR, une déclaration de réception des marchandises ;
b) en cas de transfert extracommunautaire, l'acheteur s'engage à :
i) présenter la déclaration en douane d'exportation (DAU-EX et DAE) et faire l'apurement du MRN (Movement Reference Number/Numéro de référence du mouvement) auprès de la douane du territoire communautaire de sortie des Produits, dans les 90 jours à compter de la date de livraison des Produits en Italie ;
ii) envoyer à PIEMME, dans un délai de 90 jours à compter de la date de livraison, les documents prouvant l'exportation des Produits (déclaration d'exportation DAU-EX, DAE et notification d'exportation) ;

iii) confirmer rapidement par écrit, à PIEMME, l'accomplissement des formalités susmentionnées et fournir tout autre document prouvant l'accomplissement desdites formalités et la sortie des Produits du territoire de l'Union européenne.

Dans le cas où l'acheteur ne respecterait pas ce qui précède, PIEMME aura le droit de facturer immédiatement à l'acheteur la Taxe sur la Valeur Ajoutée relative à la fourniture et liée à l'absence de preuve du transport des Produits vers un autre État membre de la Communauté Européenne ou au défaut d'apurement de l'exportation. En tout état de cause, l'acheteur tiendra PIEMME quitte et indemne du paiement de toute somme susceptible d'être due par PIEMME à l'Administration fiscale, à titre de pénalités et d'intérêts ou à tout autre titre, en relation avec la fourniture et l'absence de preuve du transport des Produits vers un autre État membre de la Communauté européenne ou le défaut d'apurement de l'exportation.

ARTICLE 5 – CONTESTATIONS

Les garanties sur les produits sont limitées au matériau céramique de premier choix uniquement, avec une tolérance de 5 % ; toute garantie est expressément exclue pour tous les produits de deuxième choix, de choix secondaire et en stock. Les réclamations pour vices apparents ne produisent des effets que si elles sont formulées par écrit avant la pose des produits. Les différences de tonalité ne constituent pas un vice donnant lieu à la garantie au sens des articles 1490 et suivants du Code civil italien. Les teintes des échantillons et reproductions doivent être considérées comme purement indicatives et non strictement contraignantes dans le cadre de la livraison. Les éventuelles réclamations pour vices ou non-conformités des Produits devront parvenir à PIEMME par écrit, par lettre recommandée avec accusé de réception ou PEC, directement à l'attention de notre « Ufficio Logistica, Qualità e Servizio Post-Vendita » (Département Logistique, Qualité et Service après-vente), dans les termes et conditions prévus par l'article 1495 du Code civil italien.

L'acheteur s'engage à mettre à disposition les lots objets de la réclamation afin que les vices ou les non-conformités signalés puissent être vérifiés. En tout état de cause, nous rappelons que la pose du matériel implique son acceptation et exonère PIEMME de toute responsabilité. L'acheteur ne pourra, en aucun cas, retourner les Produits sans l'autorisation expresse, préalable et écrite de PIEMME. Les éventuels vices ou non-conformités des Produits, dans la mesure où ils sont signalés dans les termes et conditions prévus par la loi et constatés ou reconnus par PIEMME, donnent droit uniquement au remplacement des Produits à condition d'un accord écrit préalable et de la restitution préalable à PIEMME des Produits défectueux ou non-conformes, avec renonciation à d'autres actions, réclamations, demandes ou recours quelconques, même de caractère compensatoire. PIEMME décline toute responsabilité quant à l'adéquation des Produits à l'usage que l'acheteur entend en faire, même dans le cas où des suggestions ou des indications quant à l'installation et à l'utilisation de ceux-ci seraient fournies par PIEMME, lesquelles ne seront en aucun cas considérées comme contraignantes pour l'acheteur.

Si la réclamation s'avère non fondée, l'acheteur sera tenu de rembourser à PIEMME tous les frais engagés par PIEMME pour la vérification et la gestion extrajudiciaire de la réclamation (déplacements, expertises, etc.). L'acheteur aura la même obligation si la réclamation s'avère seulement partiellement fondée.

ARTICLE 6 – PRIX

Les prix figurant sur les listes de prix de PIEMME s'entendent Départ usine (départ entrepôt du vendeur), hors TVA et remises. Ces prix ne comprennent pas, entre autres, les frais d'expédition, de transport, d'assurance éventuelle, ni d'autres frais (taxes, droits, etc.). Le prix des Produits est celui de la liste de prix en vigueur au moment de la confirmation de la commande ou, si les Produits ne figurent pas dans la liste de prix, leur prix sera celui mentionné dans la commande. Même après confirmation de la commande et jusqu'au moment de la livraison des marchandises, PIEMME aura le droit de modifier les prix en raison de l'augmentation du coût des matières premières, de la main-d'œuvre, de l'énergie et d'autres coûts de production. Dans ce cas, l'acheteur pourra se rétracter du contrat par notification écrite, à envoyer par lettre recommandée avec accusé de réception ou PEC, dans un délai de 30 jours à compter de la réception de la communication par PIEMME de la variation du prix des Produits.

ARTICLE 7 – PAIEMENT

Le paiement sera effectué, sauf accord écrit contraire, dans les locaux de PIEMME ou auprès d'une banque indiquée par PIEMME. Tout paiement effectué à des agents, représentants ou auxiliaires commerciaux de PIEMME, dans la mesure où il a été préalablement autorisé par écrit par PIEMME, aura pour effet de libérer l'acheteur.

Tout retard ou toute irrégularité dans le paiement des Produits autorisera PIEMME à suspendre les fournitures ou à résilier les contrats en cours, même s'ils ne sont pas liés aux paiements en question, sans préjudice, en tout état de cause, du droit à la réparation des dommages éventuels. Le retard de paiement par l'acheteur entraîne, sans qu'il soit nécessaire de procéder à une mise en demeure, l'application d'intérêts moratoires au taux prévu par le décret législatif italien n° 231/2002 jusqu'au remboursement intégral des frais de justice et d'assistance, tant extrajudiciaires que judiciaires. L'acheteur ne pourra en aucun cas retarder ou suspendre le paiement, quelles que soient les réclamations et/ou plaintes formulées. Aucune contestation sur les vices ou non-conformités, ainsi que sur tout autre litige existant entre PIEMME et l'acheteur concernant l'exécution des contrats de vente des Produits, ne produira d'effets ni ne pourra être prise en considération, de même qu'aucune action ne pourra être engagée avant le paiement complet du prix (clause solve et repete).

ARTICLE 8 – RÉSERVE DE PROPRIÉTÉ

La vente des Produits implique une clause de réserve de propriété. En conséquence, dans le cas où le paiement, en raison d'accords contractuels, doit être effectué en tout ou partie après la livraison, les Produits livrés restent la propriété de PIEMME jusqu'au paiement intégral du prix.

ARTICLE 9 – FORCE MAJEURE ET ONÉROSITÉ EXCESSIVE

PIEMME peut, sans charges, pénalités ou responsabilités de toute sorte et nature, même pas de nature compensatoire, suspendre, en tout ou en partie, l'exécution du contrat, ou se rétracter, en tout ou en partie, de ce contrat, si l'exécution est objectivement impossible ou excessivement onéreuse, en raison d'événements de force majeure (sans aucune prétention d'exhaustivité, grèves, accidents, explosions, incendies, guerres, événements

naturels, épidémies, interdictions légales, absence, retards ou difficultés d'approvisionnement en matières premières, pannes et/ou causes similaires, etc.).

ARTICLE 10 – CESSION DU CONTRAT

L'acheteur ne peut pas céder le contrat, ou les différents rapports d'obligation en découlant, sans l'acceptation écrite de PIEMME. Même dans ce cas, l'acheteur reste toutefois responsable solidairement avec le cessionnaire, des obligations cédées.

ARTICLE 11 – INTERPRÉTATION, MODIFICATIONS, CLAUSES INVALIDES

Pour l'interprétation des présentes conditions générales, seule la version italienne fait foi. Les annexes ou les introductions sont réputées faire partie intégrante des contrats auxquels elles se rapportent.

Toute référence à listes de prix, conditions générales ou autres documents de PIEMME est réputée se rapporter aux documents en vigueur au moment de la référence, sauf indication contraire. Tout texte précédent en vigueur entre les parties est réputé nul et non venu.

Les déclarations faites ou le comportement adopté par les parties, lors des négociations ou au cours de l'exécution du contrat, peuvent contribuer uniquement à l'interprétation du contrat auquel ces déclarations et comportement se rapportent et dans la mesure où ils ne s'opposent pas aux présentes conditions générales ou aux accords conclus par écrit par les parties lors de la signature du contrat en question.

Sauf dans les cas prévus à l'art. 2) ci-dessus, les modifications ou les intégrations apportées par les parties aux contrats auxquels s'appliquent les présentes conditions générales, doivent être faites par écrit, sous peine de nullité. La renonciation à une ou plusieurs dispositions des présentes conditions générales ne doit pas être interprétée de manière extensive ou par analogie, ni n'implique l'intention de ne pas appliquer les conditions générales dans leur ensemble.

Les modifications des conditions contractuelles convenues entre les parties ne constituent pas une novation du contrat, sauf mention contraire expresse et écrite. En cas de dispositions contractuelles invalides ou inefficaces, le contrat doit être intégré dans son ensemble afin d'atteindre, d'une manière conforme à la loi, l'objectif essentiel poursuivi par l'accord contenant les clauses en question.

L'éventuelle tolérance de comportements, en violation des dispositions contenues dans les présentes conditions générales, ne constitue pas une renonciation aux droits découlant des dispositions violées ni au droit d'exiger la bonne exécution de tous les termes et conditions prévus.

ARTICLE 12 – TRIBUNAL COMPÉTENT

Le présent contrat est régi par le droit italien, y compris le droit procédural. Pour tout litige relatif ou lié de quelque manière que ce soit aux contrats auxquels s'appliquent les présentes conditions générales, la compétence est attribuée aux tribunaux italiens. Tout litige découlant de l'interprétation et de l'exécution des présentes conditions générales sera réglé par le tribunal de Reggio Emilia.

ARTICLE 13 – PROPRIÉTÉ INDUSTRIELLE ET DISTRIBUTION SÉLECTIVE – LIMITES DE REVENTE

La signature des présentes conditions générales ne donne, en aucun cas, à l'acheteur le droit d'utiliser, sous quelque forme que ce soit, les marques de PIEMME et/ou d'autres signes distinctifs de cette dernière. Leur utilisation éventuelle devra être préalablement autorisée par PIEMME et expressément réglementée dans un acte séparé. Les fournisseurs de Produits PIEMME sont destinés à être installés dans les locaux de l'utilisateur final et aucune autre forme de revente à des intermédiaires commerciaux autres que les utilisateurs finaux n'est autorisée, sauf autorisation écrite préalable de PIEMME et sauf si l'achat des Produits a lieu dans des points de vente expressément autorisés par PIEMME à cet effet. La revente de Produits en violation de cette interdiction doit donc être considérée comme non autorisée et assimilée à une utilisation illicite des droits de propriété industrielle et intellectuelle de PIEMME, avec le droit pour PIEMME d'en demander la saisie auprès de tout détenteur. Il est entendu que PIEMME se réserve le droit d'engager des poursuites judiciaires contre toute personne impliquée dans une revente non autorisée.

ARTICLE 14 – INFORMATION SOMMAIRE

Conformément à l'art. 13 du règlement UE 2016/679, nous vous informons que vos données sont stockées dans des bases de données électroniques et papier et sont traitées par des personnes autorisées exclusivement à des fins administratives et comptables. Les données pourront être communiquées à des tiers pour l'exécution de relations existantes ou pour l'accomplissement d'obligations légales, mais ne seront pas divulguées. Nous vous informons également que vous pouvez, à tout moment, demander l'accès aux données et vous opposer à certaines utilisations en contactant le Responsable du traitement.

Remarque : Cette information sommaire est complétée par d'autres informations méthodiques et exhaustives, disponibles gratuitement auprès du siège social ou en consultant les sur le site Web de la société: http://www.ceramichepiemme.fr, en cliquant sur le lien suivant « Informations sur la protection de la vie privée » https://www.ceramichepiemme.fr/privacy.

Project Management
Mktg Piemme

Finito di stampare a Febbraio 2024
Printed in February 2024

“”
Ceramics of Italy

CERAMICHE PIEMME

FLOOR AND MORE

INDUSTRIE CERAMICHE PIEMME S.P.A.
VIA DEL CROCIALE 42/44, 41042 FIORANO (MO) - ITALY
T. +39 0536.849111 - F. +39 0536.849402
WWW.CERAMICHEPIEMME.IT - INFO@CERAMICHEPIEMME.IT